

HONDA
MARINE

BF2D•BF2.3D

OWNER'S MANUAL

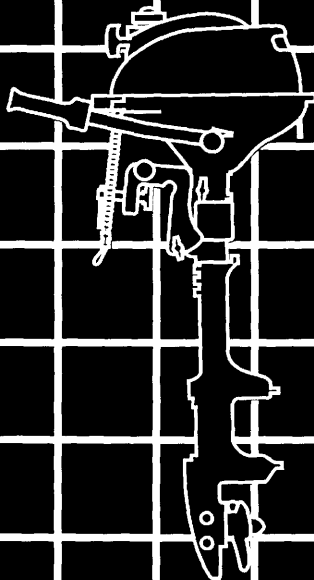

ECOLOGY CONSCIOUS TECHNOLOGY



ECOLOGY CONSCIOUS TECHNOLOGY

The “e-SPEC” mark symbolizes environmentally responsible technologies applied to Honda power equipment, which contains our wish to “preserve nature for generations to come.”

Thank you for purchasing a Honda Outboard Motor.

This manual covers operation and maintenance of the Honda BF2D/BF2.3D Outboard Motor.

All information in this publication is based on the latest product information available at the time of approval for printing.

Honda Motor Co., Ltd. reserves the right to make changes at any time without notice and without incurring any obligation.

No part of this publication may be reproduced without written permission.

This manual should be considered a permanent part of the Outboard Motor and should remain with it if it is resold.

Throughout this manual, you will see safety messages preceded by the following words and symbols. Here's what they mean:

▲ DANGER

Indicates serious injury or death WILL result if instructions are not followed.

▲ WARNING

Indicates a strong possibility that serious personal injury or death may result if instructions are not followed.

▲ CAUTION

Indicates a possibility that personal injury or equipment damage could result if instructions are not followed.

NOTICE

Indicates that equipment or property damage could result if instructions are not followed.

NOTE: Gives helpful information.

If a problem should arise, or if you have any questions about the Outboard Motor, consult an authorized Honda Outboard Motor dealer.

▲ WARNING

Honda Outboard Motors are designed to give safe and dependable service if operated according to instructions. Read and understand the Owner's Manual before operating the Outboard Motor. Failure to do so could result in personal injury or equipment damage.

- The illustration may vary according to the type.

Honda Motor Co., Ltd. 2003, All Rights Reserved

Model		BF2D					BF2.3D							
Type		SD	SCD	SHD	LD	LCHD	SU	SCU	SHU	SCHK SCHU	LU	LCU	LHU	LCHK LCHU
Shaft Length	Short	●	●	●			●	●	●	●				
	Long				●	●					●	●	●	●
Throttle type	Lever	●	●		●		●	●			●	●		
	Grip			●		●			●	●			●	●
Centrifugal clutch			●			●		●		●		●		●

NOTE: Note that the types of the outboard motor differ according to the countries where they are sold.

BF2D is provided with the following types according to the shaft length, throttle type and the equipment whether a centrifugal clutch is installed or not.

K type is an outboard motor which meets all the requirements of the emission control regulations established for Bodensee-Lake Constance.

TYPE CODE

Example

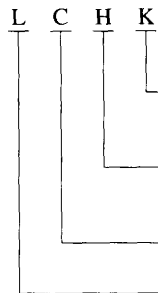

Destination

D: General Export, K: Bodensee-Lake Constance,

U: Europe (BF2.3D)

Throttle type

H: Throttle grip type

None: Throttle lever type

C: The motor is equipped with a centrifugal clutch.

None: The motor is not equipped with a centrifugal clutch.

Shaft Length

S: Short Shaft, L: Long Shaft

Check the type of your outboard motor and read this Owner's Manual thoroughly before operation. Texts with no type indication are the information and/or procedures common to all types.

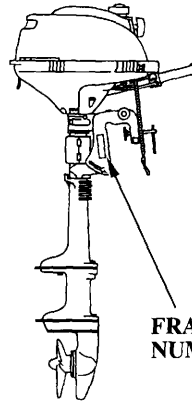

FRAME SERIAL NUMBER

Record the frame and engine serial numbers for your reference. Refer to the serial numbers when ordering parts, and when making technical or warranty inquiries.

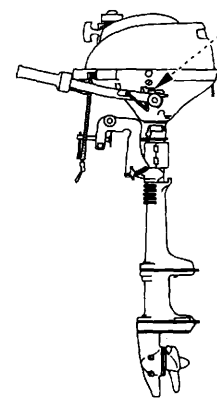

**ENGINE SERIAL NUMBER
(inside the engine cover)**

The frame serial number is stamped on the stern bracket.
The engine serial number is stamped on the clutch housing.

Frame serial number:

Engine serial number:

CONTENTS

1. SAFETY	6	6. PRE-OPERATION CHECKS	22
Safety Information	6	Removing/Installing Engine Cover	22
2. SAFETY LABEL LOCATIONS	8	Engine Oil Level	23
CE mark location	9	Fuel Level	24
3. COMPONENT IDENTIFICATION	10	Gasoline Containing Alcohol	25
4. CONTROLS	11	Other Checks	26
Starter Grip	11	7. STARTING THE ENGINE	27
Choke Knob	11	Starting the Engine	27
Emergency Stop Switch	11	Emergency Starting	31
Throttle Lever/Throttle Grip	12	Troubleshooting Starting Problems	33
Throttle Grip Friction Knob	13	8. OPERATION	34
Fuel Valve Lever	13	Operation	34
Oil Level Inspection Window	13	Tilting the Motor	37
Emergency Stop Switch Lanyard/Clip	14	Shallow Water Operation	39
Tilt Lever	15	High Altitude Operation	39
Anode Metal	15	9. STOPPING THE ENGINE	40
Engine Cover Retaining Strap	16	10. TRANSPORTING	42
Steering Friction Bolt	16	Transporting	42
Transom Angle Adjusting Bolt and Wing Nut	16	Trailerling	45
Fuel Filler Cap Vent Knob	17	11. CLEANING AND FLUSHING	46
Clamp Screws	17		
5. INSTALLATION	18		
Transom Height	18		
Location	18		
Installation Height	19		
Motor Attachment	20		
Motor Angle	20		

CONTENTS

12. MAINTENANCE	47
Tool Kit and Spare Parts	48
MAINTENANCE SCHEDULE	49
Engine Oil Change	51
Gear Oil Change.....	52
Starter Rope Check	53
Spark Plug Service	54
Lubrication	56
Shear Pin Change	57
Servicing a Submerged Motor	58
EMISSION CONTROL SYSTEM.....	59
13. STORAGE	60
Draining the Gasoline	60
Engine Oil	62
Storage Position of the Outboard Motor	62
14. TROUBLESHOOTING.....	64
15. SPECIFICATIONS.....	66
16. WIRING DIAGRAM.....	69
17. MAJOR Honda DISTRIBUTOR ADDRESSES IN EUROPE.....	70
18. INDEX	73

1. SAFETY

SAFETY INFORMATION

For your safety and the safety of others, pay special attention to these precautions.

Operator Responsibility



- **Honda outboard motor is designed to give safe and dependable service if operated according to instructions. Read and understand the Owner's Manual before operating the outboard motor. Failure to do so could result in personal injury or equipment damage.**



- **The engine system will be heated during operation and remain hot immediately after stopping the engine.**

- Know how to stop the engine quickly in case of emergency. Understand the use of all controls.
- Do not exceed the boat manufacturer's power recommendation, and be sure that the outboard motor is properly mounted.
- Never permit anyone to operate the outboard motor without proper instruction.
- Stop the engine immediately if anyone falls overboard.
- Do not run the motor while the boat is near anyone in the water.
- Attach the emergency stop switch lanyard securely to the operator.
- Before operating the outboard motor, familiarize yourself with all laws and regulations relating to boating and the use of outboard motors.

- Do not attempt to modify the outboard motor.
- Always wear a life-jacket when on board.
- Do not operate the outboard motor without the engine cover. Exposed moving parts can cause injury.
- Do not remove any guards, labels, shields, covers or safety devices; they are installed for your safety.

Fire and Burn Hazards

Gasoline is extremely flammable, and gasoline vapor can explode. Use extreme care when handling gasoline.

KEEP OUT OF REACH OF CHILDREN.

- Refuel in a well-ventilated area with the engine stopped. Keep flames and sparks away, and do not smoke in the area.

- Refuel carefully to avoid spilling fuel. Avoid overfilling the fuel tank (there should be no fuel in the filler neck). After refueling, tighten the fuel filler cap securely. If any fuel is spilled, make sure the area is dry before starting the engine.

The engine and exhaust system become very hot during operation and remain hot for a while after stopping. Contact with hot engine components can cause burns and may ignite some materials.

- Avoid touching a hot engine or exhaust system.
- Allow the engine to cool before performing maintenance or transporting.

Carbon Monoxide Poisoning Hazard

Exhaust contains poisonous carbon monoxide, a colorless and odorless gas. Breathing exhaust can cause loss of consciousness and may lead to death.

- If you run the engine in an area that is confined, or even partially enclosed, the air can become contaminated with a dangerous amount of exhaust gas. To keep exhaust gas from building up, provide adequate ventilation.

2. SAFETY LABEL LOCATIONS

[Equipped type]

These labels warn you of potential hazards that can cause serious injury. Read the labels and safety notes and precautions described in this manual carefully. If a label comes off or becomes hard to read, contact your Honda outboard motor dealer for a replacement.

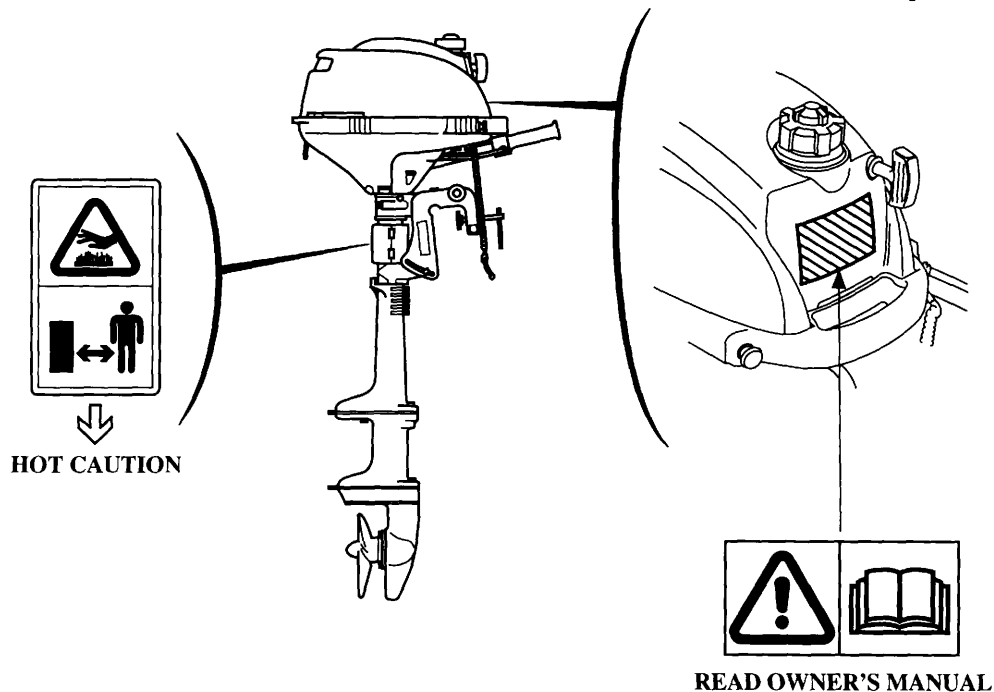

SAFETY LABEL LOCATIONS

CE mark location
[BF2.3D]

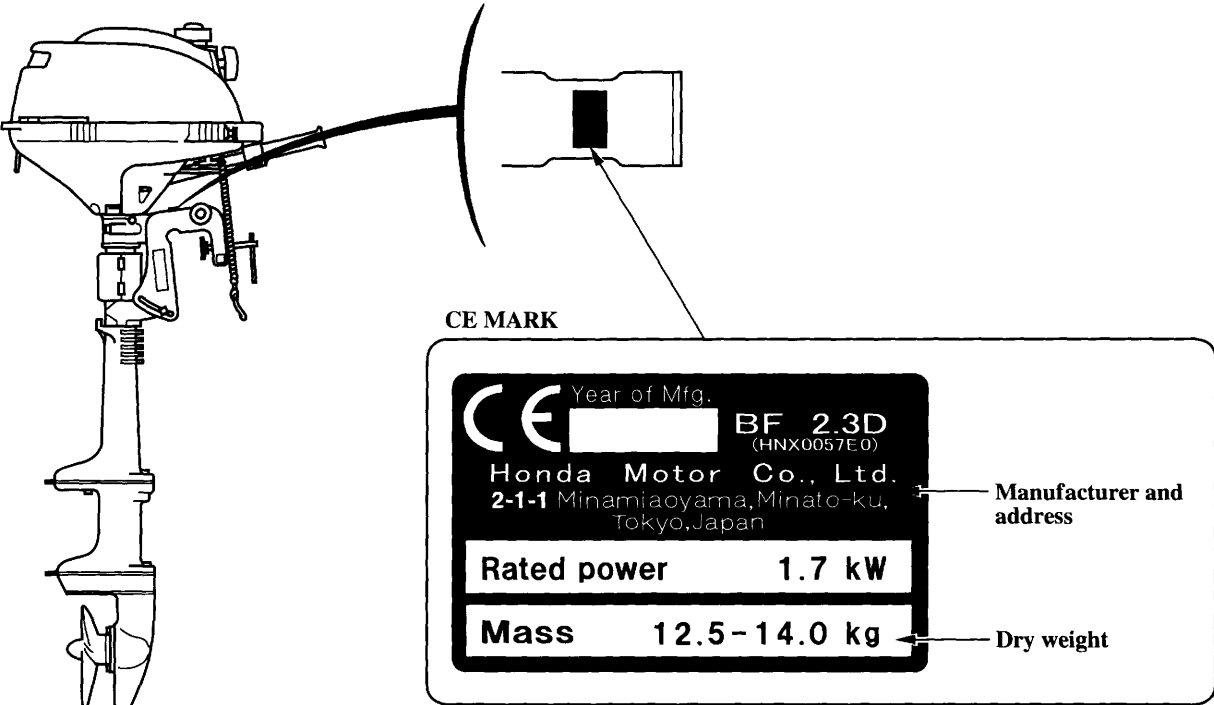

3. COMPONENT IDENTIFICATION

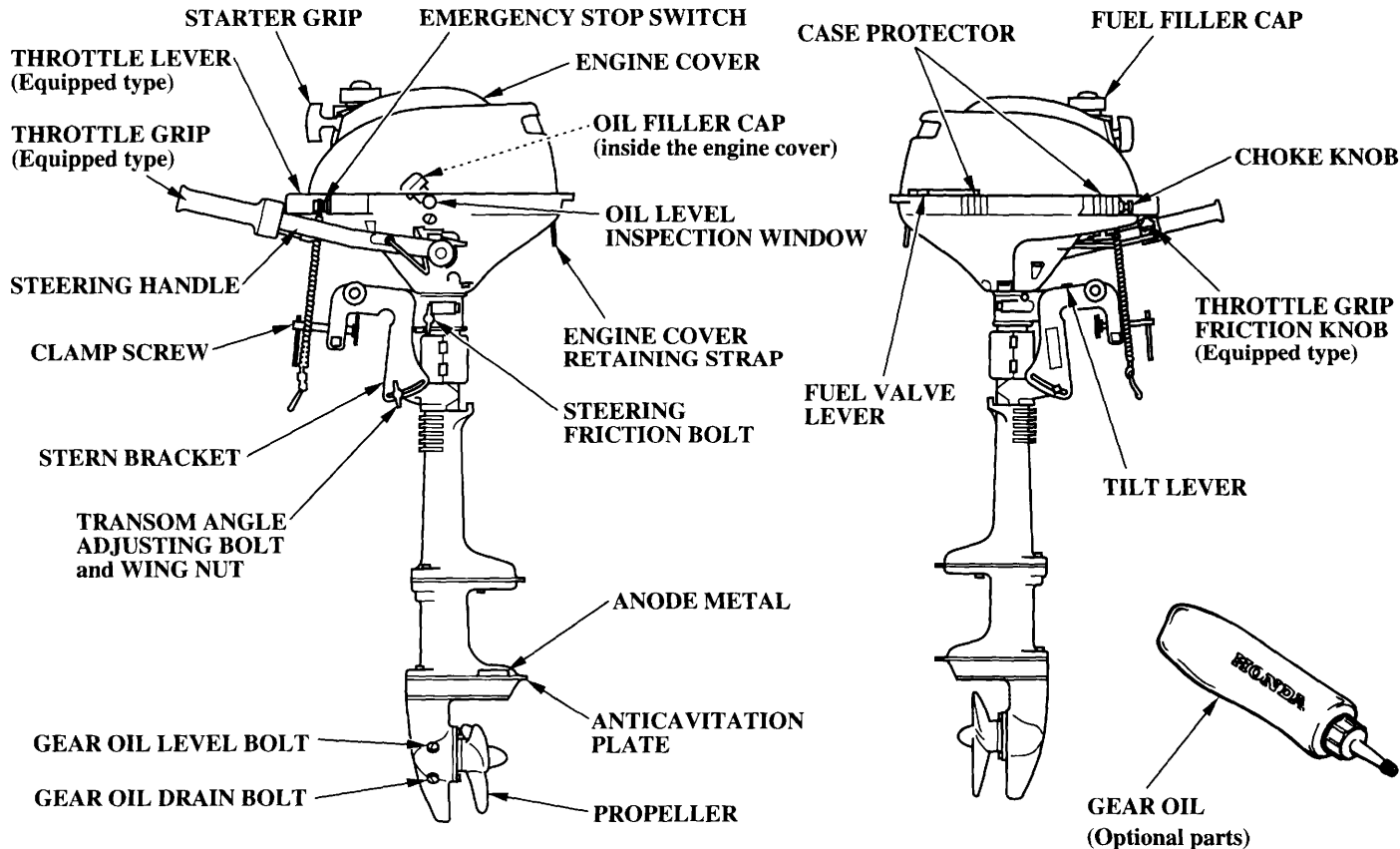

4. CONTROLS

Starter Grip

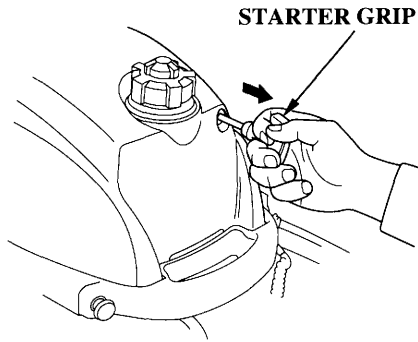

Use the starter grip to start the engine.

Choke Knob

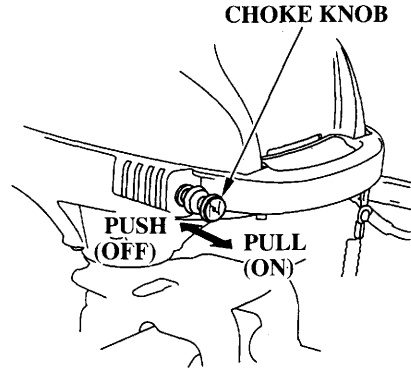

When the engine is cold, pull the choke knob to start easily. Rich fuel mixture is provided to the engine by pulling the choke knob.

Emergency Stop Switch

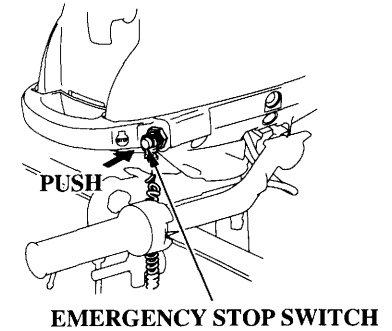

Press the emergency stop switch to stop the engine.

CONTROLS

Throttle Lever/Throttle Grip

Move the throttle lever or the throttle grip in the directions shown to make the engine run faster or slower.

THROTTLE LEVER type:

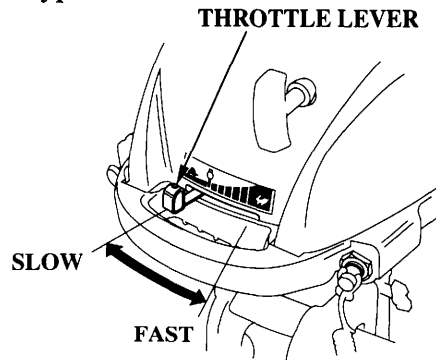

THROTTLE GRIP type:

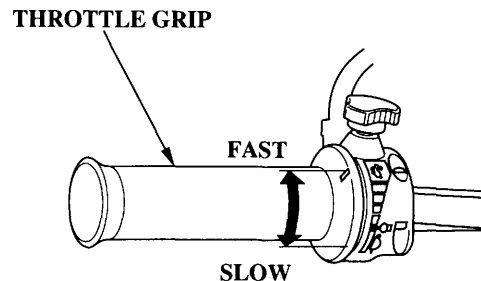

Throttle Grip Friction Knob

THROTTLE GRIP FRICTION KNOB

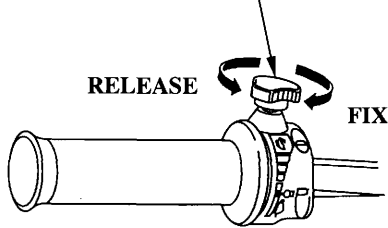

Use the throttle grip friction knob to cruise at a certain constant speed. Turning the throttle grip friction knob clockwise fixes the throttle grip in the place, and it is released by turning the throttle grip friction knob counterclockwise.

Fuel Valve Lever

FUEL VALVE LEVER

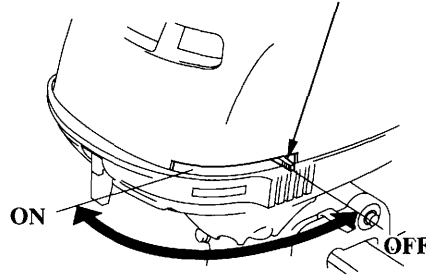

Turn the fuel valve lever ON to open the fuel valve for the engine to run.

Oil Level Inspection Window

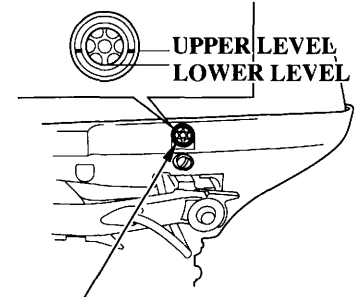

OIL LEVEL INSPECTION WINDOW

Use the oil level inspection window to check the engine oil level with the engine stopped and the outboard motor in the upright position.

CONTROLS

Emergency Stop Switch Lanyard/ Clip

EMERGENCY STOP
SWITCH LANYARD

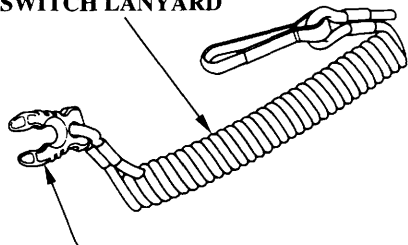

EMERGENCY STOP SWITCH CLIP

The emergency stop switch lanyard is provided to stop the engine immediately when the operator falls overboard or away from the outboard motor.

The engine stops when the clip at the end of the emergency stop switch lanyard is pulled out of the emergency stop switch.

When operating the outboard motor, be sure to attach one end of the emergency stop switch lanyard securely to the operator.



SPARE EMERGENCY STOP
SWITCH CLIP

▲WARNING

If the emergency stop switch lanyard is not set, the boat might run out of control when the operator, for example, falls overboard and is not able to operate the outboard motor.

For the sake of the operator's and the passengers' safety, be sure to set the emergency stop switch clip located at one end of the emergency stop switch lanyard with the emergency stop switch. Attach the other end of

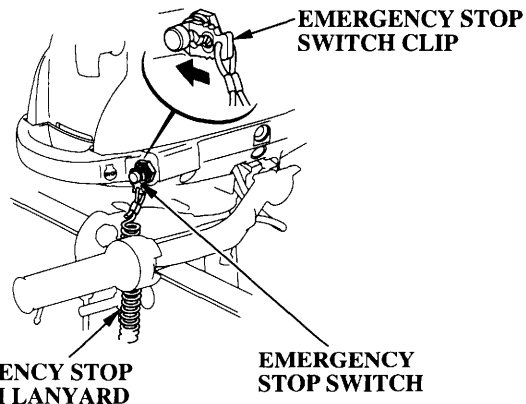

EMERGENCY STOP
SWITCH CLIP

EMERGENCY STOP
SWITCH LANYARD

EMERGENCY
STOP SWITCH

the emergency stop switch lanyard securely to the operator.

NOTE:

The engine does not start unless the emergency stop switch clip is set on the emergency stop switch. A spare emergency stop switch clip is provided in the tool bag.

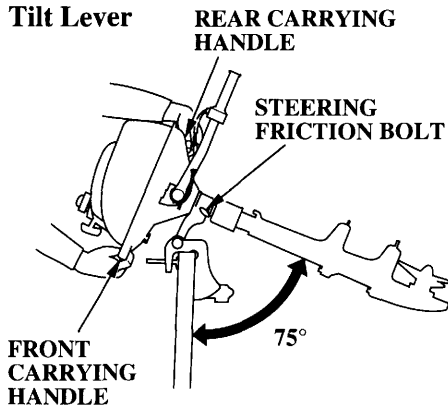

Use the tilt lever to tilt the motor for shallow water operation, beaching, launching, or mooring. Tilt the outboard motor by holding the carrying handles, as shown. The spring-loaded tilt lever will automatically move into position and hold the outboard motor when it reaches approximately 75°.

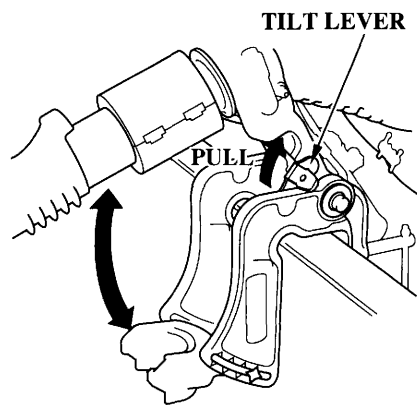

To return the outboard motor to the normal running position, hold the outboard motor and pull the tilt lever, then slowly lower the outboard motor.

Anode Metal

Short shaft type

Long shaft type

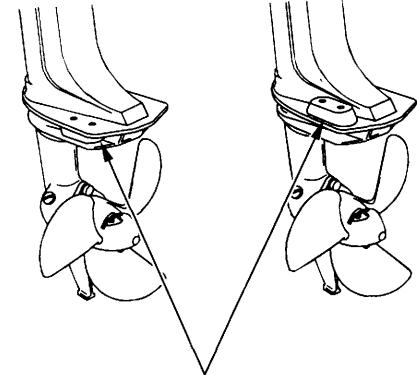

The anode metal is a sacrificed metal which protects the outboard from corrosion.