



**OWNER'S MANUAL
USO E MANUTENZIONE
MANUAL DEL PROPIETARIO**



**CBR1000RR
FIRE BLADE**

**Honda CBR1000RR
FIRE BLADE**

OWNER'S MANUAL

USO E MANUTENZIONE

MANUAL DEL PROPIETARIO

IMPORTANT INFORMATION

- **OPERATOR AND PASSENGER**

This motorcycle is designed to carry the operator and one passenger. Never exceed the maximum weight capacity as shown on the accessories and loading label.

- **ON-ROAD USE**

This motorcycle is designed to be used only on the road.

- **READ THIS OWNER'S MANUAL CAREFULLY**

Pay special attention to the safety messages that appear throughout the manual. These messages are fully explained in the "A Few Words About Safety" section which appears before the Contents page.

This manual should be considered a permanent part of the motorcycle and should remain with the motorcycle when resold.

**Honda CBR1000RR
FIRE BLADE
OWNER'S MANUAL**

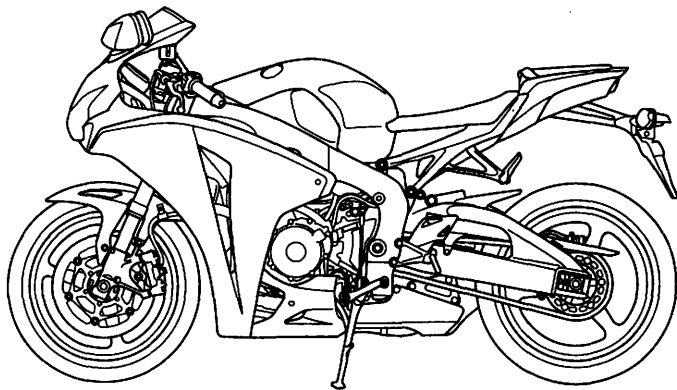

All information in this publication is based on the latest production information available at the time of approval for printing. Honda Motor Co.,Ltd. reserves the right to make changes at any time without notice and without incurring any obligation.

No part of this publication may be reproduced without written permission.

WELCOME

The motorcycle presents you a challenge to master the machine, a challenge to adventure. You ride through the wind, linked to the road by a vehicle that responds to your commands as no other does. Unlike an automobile, there is no metal cage around you. Like an airplane, a pre-ride inspection and regular maintenance are essential to your safety. Your reward is freedom.

To meet the challenges safely, and to enjoy the adventure fully, you should become thoroughly familiar with this owner's manual **BEFORE YOU RIDE THE MOTORCYCLE**.

As you read this manual, you will find information that is preceded by a **NOTICE** symbol. This information is intended to help you avoid damage to your motorcycle, other property, or the environment.

When service is required, remember that your Honda dealer knows your motorcycle best. If you have the required mechanical "know-how" and tools, your dealer can supply you with an official Honda Shop Manual to help you perform many maintenance and repair tasks.

Pleasant riding, and thank you for choosing a Honda !

- The following codes in this manual indicate each country.
- The illustrations herein are based on the ED type.

E	UK
F	France
ED	European direct sales
	Austria Italy
	Belgium Northern Europe
	Germany Portugal
	Greece Spain
	Holland Switzerland
	Ireland
U	Australia New Zealand
BR	Brazil

- The specifications may vary with each locale.

A FEW WORDS ABOUT SAFETY

Your safety, and the safety of others, is very important. And operating this motorcycle safely is an important responsibility.

To help you make informed decisions about safety, we have provided operating procedures and other information on labels and in this manual. This information alerts you to potential hazards that could hurt you or others.

Of course, it is not practical or possible to warn you about all hazards associated with operating or maintaining a motorcycle. You must use your own good judgment.

You will find important safety information in a variety of forms, including:

- **Safety Labels** — on the motorcycle.
- **Safety Messages** — preceded by a safety alert symbol  and one of three signal words: **DANGER, WARNING, or CAUTION.**

These signal words mean:

▲ DANGER

You **WILL** be **KILLED** or **SERIOUSLY HURT** if you don't follow instructions.

▲ WARNING

You **CAN** be **KILLED** or **SERIOUSLY HURT** if you don't follow instructions.

▲ CAUTION

You **CAN** be **HURT** if you don't follow instructions.

- **Safety Headings** — such as Important Safety Reminders or Important Safety Precautions.
- **Safety Section** — such as Motorcycle Safety.
- **Instructions** — how to use this motorcycle correctly and safely.

This entire manual is filled with important safety information — please read it carefully.

OPERATION

page

1 MOTORCYCLE SAFETY

- 1 IMPORTANT SAFETY INFORMATION
- 2 PROTECTIVE APPAREL
- 4 LOAD LIMITS AND GUIDELINES

8 PARTS LOCATION

- 11 INSTRUMENTS AND INDICATORS

41 MAJOR COMPONENTS

(Information you need to operate this motorcycle)

- 41 SUSPENSION
- 47 BRAKES
- 50 CLUTCH
- 53 COOLANT
- 55 FUEL
- 58 ENGINE OIL
- 59 TUBELESS TYRES

page

65 ESSENTIAL INDIVIDUAL COMPONENTS

- 65 IGNITION SWITCH
- 66 KEYS
- 68 IMMOBILIZER SYSTEM (HISS)
- 71 RIGHT HANDLEBAR CONTROLS
- 72 LEFT HANDLEBAR CONTROLS
- 74 HESD (Honda Electronic Steering Damper)

page

75 FEATURES

(Not required for operation)

- 75 STEERING LOCK
- 76 SEAT
- 78 HELMET HOLDERS
- 79 DOCUMENT BAG
- 80 STORAGE COMPARTMENT FOR
U-SHAPED ANTI-THEFT LOCK
- 81 LOWER COWL
- 82 HEADLIGHT AIM VERTICAL
ADJUSTMENT

page

83 OPERATION

- 83 PRE-RIDE INSPECTION
- 85 STARTING THE ENGINE
- 89 RUNNING-IN
- 90 RIDING
- 92 BRAKING
- 93 PARKING
- 94 ANTI-THEFT TIPS

MAINTENANCE

page

95 MAINTENANCE

- 95 THE IMPORTANCE OF MAINTENANCE
- 96 MAINTENANCE SAFETY
- 97 SAFETY PRECAUTIONS
- 98 MAINTENANCE SCHEDULE
- 101 TOOL KIT
- 102 SERIAL NUMBERS
- 103 COLOUR LABEL
< Except BR type >
- 104 ENGINE OIL
- 110 THROTTLE OPERATION
- 111 COOLANT
- 112 DRIVE CHAIN
- 118 DRIVE CHAIN SLIDER
- 119 FRONT AND REAR SUSPENSION INSPECTION
- 120 SIDE STAND
- 121 WHEEL REMOVAL
- 127 BRAKE PAD WEAR
- 129 BATTERY

page

- 131 FUSE REPLACEMENT
- 134 BRAKELIGHT SWITCH ADJUSTMENT
- 135 BULB REPLACEMENT
- 142 CLEANING**
- 147 STORAGE GUIDE**
- 147 STORAGE
- 149 REMOVAL FROM STORAGE
- 150 SPECIFICATIONS**
- 154 CATALYTIC CONVERTER**

MOTORCYCLE SAFETY

IMPORTANT SAFETY INFORMATION

Your motorcycle can provide many years of service and pleasure — if you take responsibility for your own safety and understand the challenges that you can meet on the road.

There is much that you can do to protect yourself when you ride. You'll find many helpful recommendations throughout this manual. Following are a few that we consider to be most important.

Always Wear a Helmet

It's a proven fact: helmets significantly reduce the number and severity of head injuries. So always wear an approved motorcycle helmet and make sure your passenger does the same. We also recommend that you wear eye protection, sturdy boots, gloves, and other protective gear (page 2).

Make Yourself Easy to See

Some drivers do not see motorcycles because they are not looking for them. To make yourself more visible, wear bright reflective clothing, position yourself so other drivers can see you, signal before turning or changing lanes, and use your horn when it will help others notice you.

Ride Within Your Limits

Pushing the limits is another major cause of motorcycle accidents. Never ride beyond your personal abilities or faster than conditions warrant. Remember that alcohol, drugs, fatigue and inattention can significantly reduce your ability to make good judgements and ride safely.

Don't Drink and Ride

Alcohol and riding don't mix. Even one drink can reduce your ability to respond to changing conditions, and your reaction time gets worse with every additional drink. So don't drink and ride, and don't let your friends drink and ride either.

Keep Your Bike in Safe Condition

For safe riding, it's important to inspect your motorcycle before every ride and perform all recommended maintenance. Never exceed load limits, and only use accessories that have been approved by Honda for this motorcycle. See page 4 for more details.

PROTECTIVE APPAREL

For your safety, we strongly recommend that you always wear an approved motorcycle helmet, eye protection, boots, gloves, long pants, and a long-sleeved shirt or jacket whenever you ride. Although complete protection is not possible, wearing proper gear can reduce the chance of injury when you ride.

Following are suggestions to help you choose proper gear.

⚠ WARNING

Not wearing a helmet increases the chance of serious injury or death in a crash.

Be sure you and your passenger always wear a helmet, eye protection and other protective apparel when you ride.

Helmets and Eye Protection

Your helmet is your most important piece of riding gear because it offers the best protection against head injuries. A helmet should fit your head comfortably and securely. A bright-coloured helmet can make you more noticeable in traffic, as can reflective strips.

An open-face helmet offers some protection, but a full-face helmet offers more. Always wear a face shield or goggles to protect your eyes and help your vision.

Additional Riding Gear

In addition to a helmet and eye protection, we also recommend:

- Sturdy boots with non-slip soles to help protect your feet and ankles.
- Leather gloves to keep your hands warm and help prevent blisters, cuts, burns and bruises.
- A motorcycle riding suit or jacket for comfort as well as protection. Bright-coloured and reflective clothing can help make you more noticeable in traffic. Be sure to avoid loose clothes that could get caught on any part of your motorcycle.

LOAD LIMITS AND GUIDELINES

Your motorcycle has been designed to carry you and one passenger. When you carry a passenger, you may feel some difference during acceleration and braking. But so long as you keep your motorcycle well-maintained, with good tyres and brakes, you can safely carry loads within the given limits and guidelines.

However, exceeding the weight limit or carrying an unbalanced load can seriously affect your motorcycle's handling, braking and stability. Non-Honda accessories, improper modifications, and poor maintenance can also reduce your safety margin.

The following pages give more specific information on loading, accessories and modifications.

Loading

How much weight you put on your motorcycle, and how you load it, are important to your safety. Anytime you ride with a passenger or cargo you should be aware of the following information.

WARNING

Overloading or improper loading can cause a crash and you can be seriously hurt or killed.

Follow all load limits and other loading guidelines in this manual.

Load Limits

Following are the load limits for your motorcycle:

Maximum weight capacity:

180 kg (397 lbs)

Includes the weight of the rider, passenger, all cargo and all accessories

Maximum cargo weight:

14 kg (31 lbs)

The weight of added accessories will reduce the maximum cargo weight you can carry.

Loading Guidelines

Your motorcycle is primarily intended for transporting you and a passenger. You may wish to secure a jacket or other small items to the seat when you are not riding with a passenger.

If you wish to carry more cargo, check with your Honda dealer for advice, and be sure to read the information regarding accessories on page 6.

Improperly loading your motorcycle can affect its stability and handling. Even if your motorcycle is properly loaded, you should ride at reduced speeds and never exceed 130 km/h (80 mph) when carrying cargo.

Follow these guidelines whenever you carry a passenger or cargo:

- Check that both tyres are properly inflated (page 59).
- If you change your normal load, you may need to adjust the front suspension (page 41) and the rear suspension (page 44).
- To prevent loose items from creating a hazard, make sure that all cargo is securely tied down before you ride away.
- Place cargo weight as close to the center of the motorcycle as possible.
- Balance cargo weight evenly on both sides.

Accessories and Modifications

Modifying your motorcycle or using non-Honda accessories can make your motorcycle unsafe. Before you consider making any modifications or adding an accessory, be sure to read the following information.

⚠ WARNING

Improper accessories or modifications can cause a crash in which you can be seriously hurt or killed.

Follow all instructions in this owner's manual regarding accessories and modifications.

Accessories

We strongly recommend that you use only Honda Genuine Accessories that have been specifically designed and tested for your motorcycle. Because Honda cannot test all other accessories, you must be personally responsible for proper selection, installation and use of non-Honda accessories. Check with your dealer for assistance and always follow these guidelines:

- Make sure the accessory does not obscure any lights, reduce ground clearance and banking angle, limit suspension travel or steering travel, alter your riding position or interfere with operating any controls.
- Be sure electrical equipment does not exceed the motorcycle's electrical system capacity (page 153). A blown fuse can cause a loss of lights or engine power.

- Do not pull a trailer or sidecar with your motorcycle. This motorcycle was not designed for these attachments, and their use can seriously impair your motorcycle's handling.

Modifications

We strongly advise you not to remove any original equipment or modify your motorcycle in any way that would change its design or operation. Such changes could seriously impair your motorcycle's handling, stability and braking, making it unsafe to ride.

Removing or modifying your lights, mufflers, emission control system or other equipment can also make your motorcycle illegal.

PARTS LOCATION

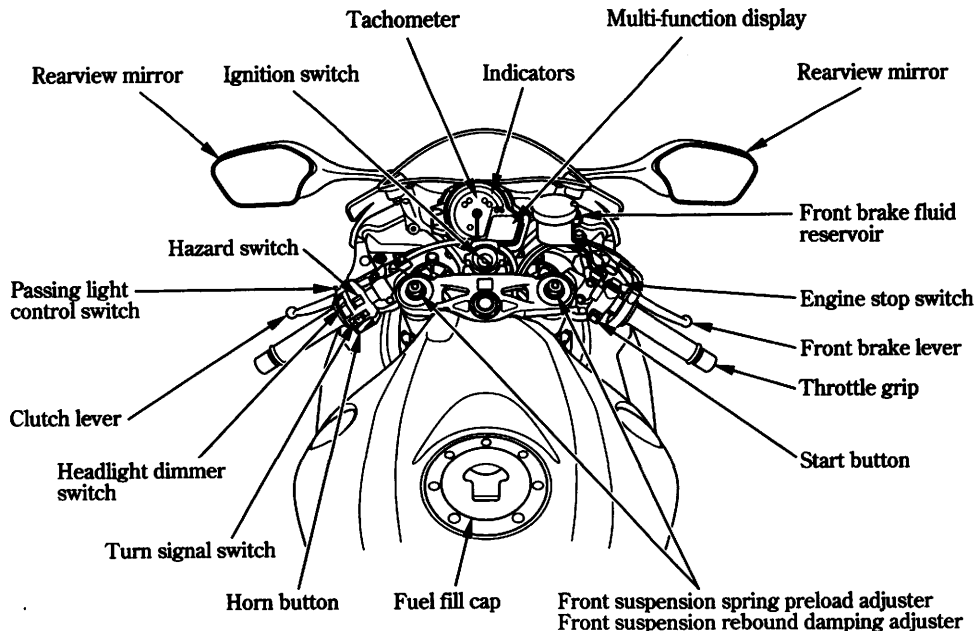

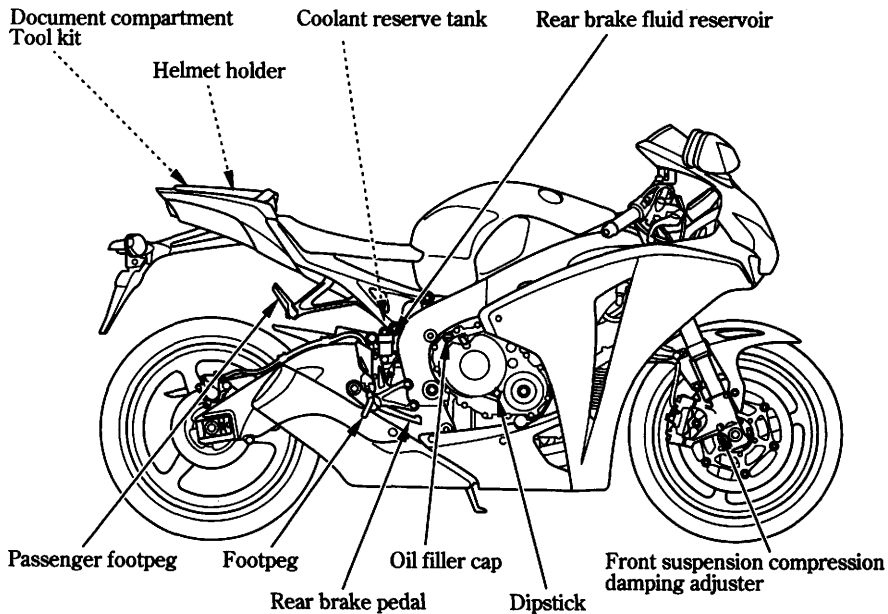

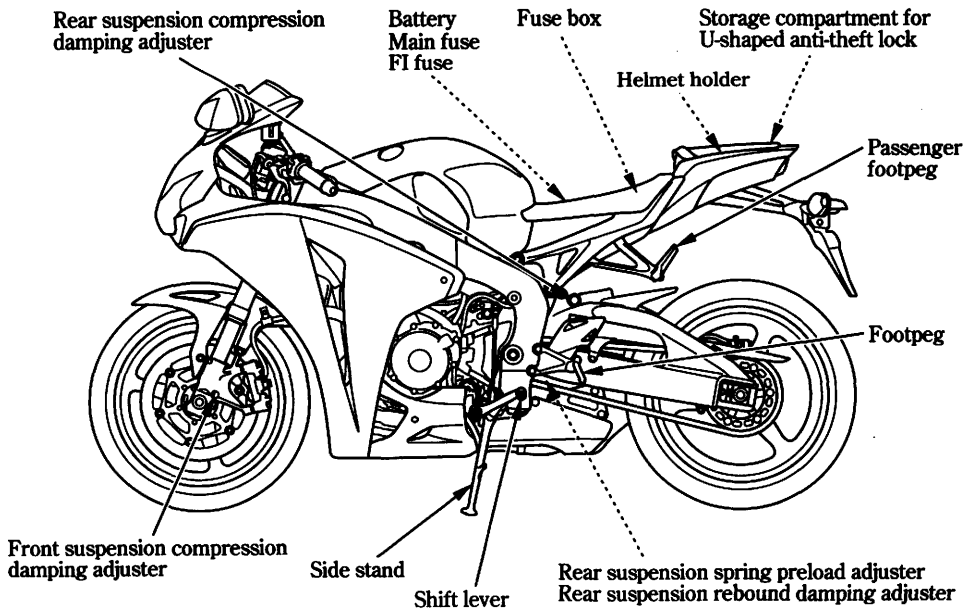

INSTRUMENTS AND INDICATORS

The indicators are contained in the instrument panel. Their functions are described in the tables on the following pages.

- (1) Control button A
- (2) Left turn signal indicator
- (3) Low fuel indicator
- (4) Neutral indicator
- (5) Tachometer
- (6) High beam indicator
- (7) PGM-FI malfunction indicator lamp (MIL)
- (8) Tachometer red zone
- (9) Tachometer red zone indicator
- (10) Right turn signal indicator
- (11) Warning indicator
- (12) Multi-function display
- (13) Immobilizer system (HISS) indicator
- (14) Control button B

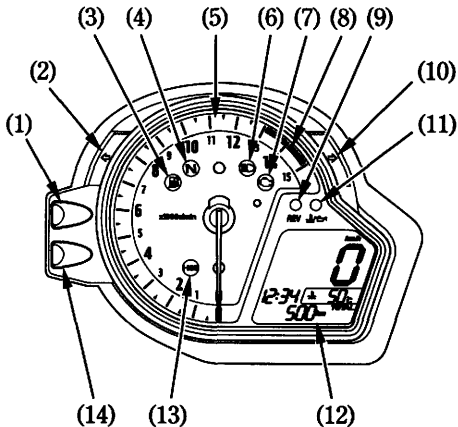

(Ref.No.) Description	Function
(1) Control button A	<p>Use this button for the following purposes.</p> <ul style="list-style-type: none"> • To change indication of odometer, tripmeter A, and tripmeter B (page 27) • To change unit of speedometer, odometer, tripmeter and fuel mileage meter (E type only) (page 34) • To change indication mode of fuel mileage (page 35) • To reset tripmeter A and fuel mileage meter (page 30) • To reset tripmeter B (page 30) • To change the reset mode of tripmeter A and fuel mileage meter (page 33) • To adjust time (page 36) • To change setting of the tachometer red zone indicator activation revolution and indication pattern (page 38) • To switch blinking of the immobilizer system (HISS) indicator (page 69)
(2) Left turn signal indicator (green)	Flashes when the left turn signal operates. Should light for a few seconds and then go off when the ignition switch is turned ON.

(Ref.No.) Description	Function
(3) Low fuel indicator (amber)	<p>Lights when there is only reserve fuel left in the fuel tank.</p> <p>The amount of fuel left in the tank when it lights with the vehicle set upright is approximately: 3.5 ℓ (0.92 US gal , 0.77 Imp gal)</p> <p>When this indicator comes on, the lower segment of the multi-function display switches to the reserve fuel consumption (page 23).</p> <p>Should also light for a few seconds and then go off when the ignition switch is turned ON.</p>
(4) Neutral indicator (green)	Lights when the transmission is in neutral.
(5) Tachometer	<p>Shows engine revolutions per minute.</p> <p>The tachometer needle will swing to the maximum scale on the dial once when the ignition switch is turned ON.</p>
(6) High beam indicator (blue)	Lights when the headlight is on high beam. Should also light for a few seconds and then go off when the ignition switch is turned ON.

(Ref.No.) Description	Function
(7) PGM-FI malfunction indicator lamp (MIL) (amber)	<p>Lights when there is any abnormality in the PGM-FI (Programmed Fuel Injection) system. Should also light for a few seconds and then go off when the ignition switch is turned ON.</p> <p>If it comes on at any other time, reduce speed and take the motorcycle to your Honda dealer as soon as possible.</p>
(8) Tachometer red zone	<p>Never allow the tachometer needle to enter the red zone, even after the engine has been broken in.</p> <p>NOTICE</p> <p>Running the engine beyond recommended maximum engine speed (the beginning of the tachometer red zone) can damage the engine.</p>
(9) Tachometer red zone indicator (amber)	<p>Flashes when the tachometer needle enters the red zone or reaches your selected revolution (page 38). Should also light for a few seconds and then go off when the ignition switch is turned ON.</p>

(Ref.No.) Description	Function
(10) Right turn signal indicator (green)	Flashes when the right turn signal operates. Should light for a few seconds and then go off when the ignition switch is turned ON.
(11) Warning indicator (red)	Lights when coolant is over the specified temperature, and/or engine oil pressure is below normal operating range. Should also light when ignition switch is ON and engine is not running. Should go out when engine starts, except for occasional flickering at or near idling speed when engine is warm. See page 24 , 25 .

(Ref.No.) Description	Function
(12) Multi-function display	The display includes the following functions; This display shows the initial display (page 19).
Low oil pressure indicator/High coolant temperature indicator/HESD indicator	Lights the low oil pressure indicator and/or high coolant temperature indicator to notify that there is an abnormality in engine oil pressure and/or coolant temperature when the warning indicator lights. See page 24 , 25 . Also, lights the HESD indicator to notify when there is an abnormality in the HESD (Honda Electronic Steering Damper) (page 26).
Speedometer	Shows riding speed (page 28).
Digital clock	Shows hour and minute (page 36).
Coolant temperature meter	Shows coolant temperature (page 21).

(Ref.No.) Description	Function						
<p>(12) Multi-function display</p> <table border="1" data-bbox="168 225 541 536"> <tr> <td data-bbox="168 225 541 293">Odometer</td> <td data-bbox="544 225 1310 293">Shows accumulated mileage (page 29).</td> </tr> <tr> <td data-bbox="168 295 541 362">Tripmeter</td> <td data-bbox="544 295 1310 362">Shows mileage per trip (page 29).</td> </tr> <tr> <td data-bbox="168 364 541 536">Fuel mileage meter</td> <td data-bbox="544 364 1310 536">Shows current fuel mileage, average fuel mileage, or fuel consumption. See pages 31 – 33 . When the low fuel indicator comes on, the display is changed to the reserve fuel consumption (page 23).</td> </tr> </table>	Odometer	Shows accumulated mileage (page 29).	Tripmeter	Shows mileage per trip (page 29).	Fuel mileage meter	Shows current fuel mileage, average fuel mileage, or fuel consumption. See pages 31 – 33 . When the low fuel indicator comes on, the display is changed to the reserve fuel consumption (page 23).	<p>The display includes the following functions;</p>
Odometer	Shows accumulated mileage (page 29).						
Tripmeter	Shows mileage per trip (page 29).						
Fuel mileage meter	Shows current fuel mileage, average fuel mileage, or fuel consumption. See pages 31 – 33 . When the low fuel indicator comes on, the display is changed to the reserve fuel consumption (page 23).						
<p>(13) Immobilizer system (HISS) indicator (red)</p>	<p>This indicator lights for a few seconds when the ignition switch is turned ON. It will then go off if the properly-coded key has been inserted. If an improperly-coded key has been inserted, the indicator will remain on and the engine will not start (page 68). When the blinking function of this indicator is valid and the ignition switch is OFF, it keeps blinking for 24 hours (page 68).</p>						

(Ref.No.) Description	Function
(14) Control button B	<p>Use this button for the following purposes.</p> <ul style="list-style-type: none"> • To change indication of current fuel mileage, average fuel mileage, and fuel consumption (page 31) • To change unit of speedometer, odometer, tripmeter and fuel mileage meter (E type only) (page 34) • To change indication mode of fuel mileage (page 35) • To change the reset mode of tripmeter A and fuel mileage meter (page 33) • To adjust time (page 36) • To change setting of the tachometer red zone indicator activation revolution and indication pattern (page 38)

Initial Display

When the ignition switch is turned ON, the multi-function display (1) will temporarily show all the modes and digital segments so that you can make sure the liquid crystal display is functioning properly.

The unit “mph” (2), “mile” (3), and “gal” (4) will be displayed only for E type.

Digital clock (5) will reset if the battery is disconnected.

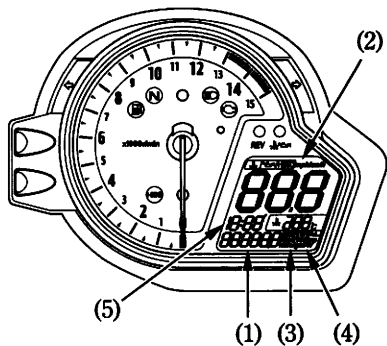

- (1) Multi-function display
- (2) “mph”
- (3) “mile”
- (4) “gal”
- (5) Digital clock

Multi-function Display

Multi-function display (1) includes the following functions:

- High coolant temperature indicator
- Low oil pressure indicator
- HESD indicator
- Speedometer
- Digital clock
- Coolant temperature meter
- Odometer
- Tripmeter
- Fuel mileage meter

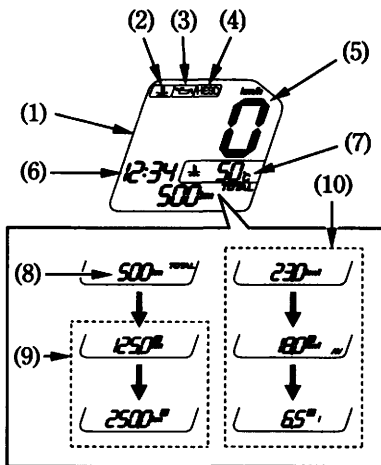

- (1) Multi-function display
- (2) High coolant temperature indicator
- (3) Low oil pressure indicator
- (4) HESD indicator
- (5) Speedometer

- (6) Digital clock
- (7) Coolant temperature meter
- (8) Odometer
- (9) Tripmeter
- (10) Fuel mileage meter

Coolant Temperature Meter

The coolant temperature meter (1) shows coolant temperature digitally.

Temperature Display

Below 34°C	“— —” is displayed.
Between 35°C and 132°C	Actual coolant temperature is indicated.
Above 132°C	The display will remain “132°C”.



(1)

(1) Coolant temperature meter

Overheating Message

When the coolant temperature reaches 122°C, the display begins to flash. At the same time, the red warning indicator (2) and the high coolant temperature indicator (3) light.

If this occurs, stop the engine and check the reserve tank coolant level. Read pages 53 – 54 and do not ride the motorcycle until the problem has been corrected.

NOTICE

Exceeding maximum running temperature may cause serious engine damage.

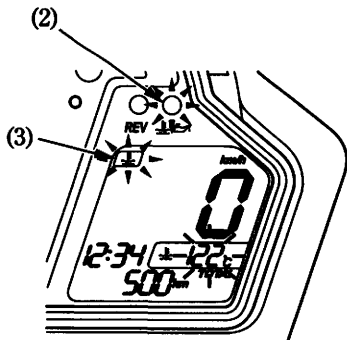

- (2) Warning indicator
- (3) High coolant temperature indicator

Low Fuel Indicator and Reserve Fuel Consumption

When the remaining fuel reaches the reserve supply level, the low fuel indicator (1) comes on and the amount of reserve fuel used is displayed with blinking to show that you should refuel.

The amount of fuel left in the tank when the low fuel indicator lights with the vehicle set upright is approximately:

3.5 ℓ (0.92 US gal , 0.77 Imp gal)

The reserve fuel consumption (2) is displayed in the lower segment of the multi-function display (3) from 0.0 "1 (liter)" or "gal (gallon)".

When the amount of consumed fuel is more than 1.0 ℓ (0.26 US gal, 0.22 Imp gal) the display blinks faster.

If you change the display to odometer, tripmeter and so on (page 27), it will return to the reserve fuel consumption after about 10 seconds.

When the reserve fuel consumption is displayed you should refill the tank as soon as possible.

After refueling more than the reserve amount, the display returns to normal when the ignition switch has been ON for about a minute.

< E type only >

The unit of the indication depends on the unit which you select (page 34).

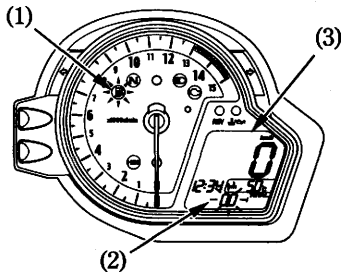

- (1) Low fuel indicator
- (2) Reserve fuel consumption
- (3) Multi-function display

Low Oil Pressure Indicator and Warning Indicator

The low oil pressure indicator (1) and the red warning indicator (2) light when engine oil pressure is below the normal operating range.

The low oil pressure indicator and the red warning indicator should light when the engine is not running with the ignition switch turned ON. Both should go off when the engine starts, except for occasional flickering at or near idling speed when the engine is warm.

NOTICE

Running the engine with insufficient oil pressure may cause serious engine damage.

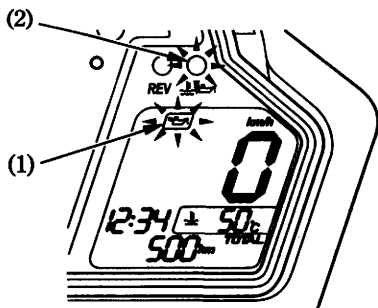

- (1) Low oil pressure indicator
- (2) Warning indicator

High Coolant Temperature Indicator and Warning Indicator

The high coolant temperature indicator (1) and the red warning indicator (2) light when the coolant is over the specified temperature. The high coolant temperature indicator should also go on for a few seconds and then go off when the ignition switch is turned ON.

If the indicators light while riding, stop the engine and check the reserve tank coolant level. Read pages 53 – 54 and do not ride the motorcycle until the problem has been corrected.

NOTICE

Exceeding maximum running temperature may cause serious engine damage.

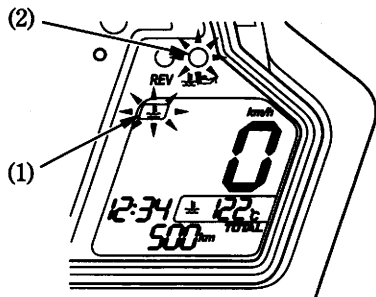

- (1) High coolant temperature indicator
- (2) Warning indicator

HESD Indicator

The HESD indicator (1) lights when there is any abnormality in the HESD (Honda Electronic Steering Damper).

The HESD indicator should also go on for a few seconds and then go off when the ignition switch is turned ON.

If the HESD indicator lights at any time, reduce speed and take the motorcycle to your Honda dealer as soon as possible.

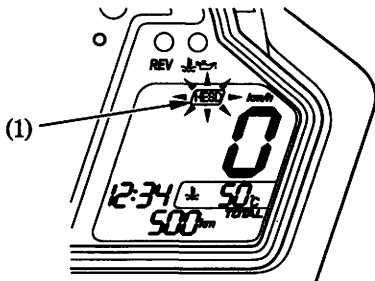

(1) HESD indicator

Speedometer/Odometer/Tripmeter/ Fuel Mileage Meter/Speed, Mileage and Fuel Mileage Unit Change

To change the indication:

Change the indication between the odometer (1), the tripmeter (2), and the fuel mileage meter (3) by pressing control button A (4) or B (5).

The fuel mileage meter includes the following functions:

- Current fuel mileage
- Average fuel mileage
- Fuel consumption

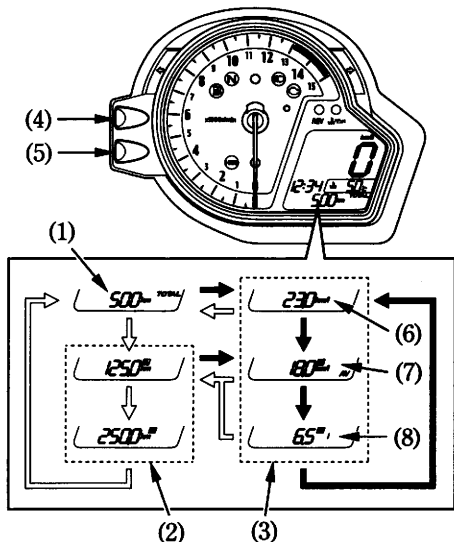

- ⇒ :Press control button A
- ➔ :Press control button B

- (1) Odometer
- (2) Tripmeter
- (3) Fuel mileage meter
- (4) Control button A
- (5) Control button B
- (6) Current fuel mileage
- (7) Average fuel mileage
- (8) Fuel consumption

Speedometer

Shows riding speed.

This shows your speed in kilometers per hour (km/h) or miles per hour (mph) depending on the type.

< E type only >

The unit of the indication depends on the unit which you select (page 34).

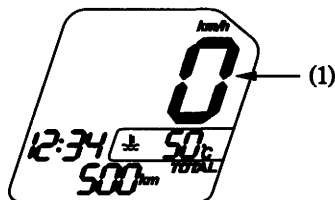

(1) Speedometer

Odometer/Tripmeter

The odometer (1) shows accumulated mileage.

The tripmeter shows mileage per trip.

There are two tripmeters, tripmeter A (2) and tripmeter B (3).

Push control button A (4) to select the odometer, tripmeter A or tripmeter B.

< E type only >

The unit of the indication depends on the unit which you select (page 34).

Tripmeter A can be displayed from 0 to 999.9 kilometers (miles). Tripmeter B can be displayed up to 9,999.9 kilometers (miles). If the display exceeds 999.9 or 9,999.9 kilometers (miles), it will return to 0 automatically.

The odometer can be displayed from 0 to 999,999 kilometers (miles).

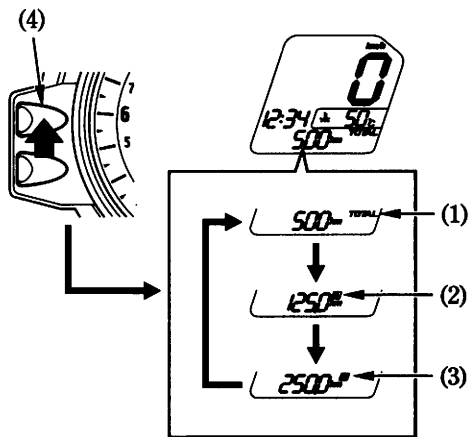

- (1) Odometer
- (2) Tripmeter A
- (3) Tripmeter B
- (4) Control button A

To reset the tripmeter:

To reset the tripmeter A (2), average fuel mileage (5), and fuel consumption (6) together, push and hold control button A (4) when either indication is displayed.

When they are reset, "0.0" is displayed at each indication. Then, the display returns to the last selected indication.

To reset the tripmeter B (3), push and hold control button A with the display in the tripmeter B.

Also, after refueling more than the reserve amount, the tripmeter A, average fuel mileage, and fuel consumption can be automatically reset.

You can activate or deactivate the automatic reset mode by refueling (page 33).

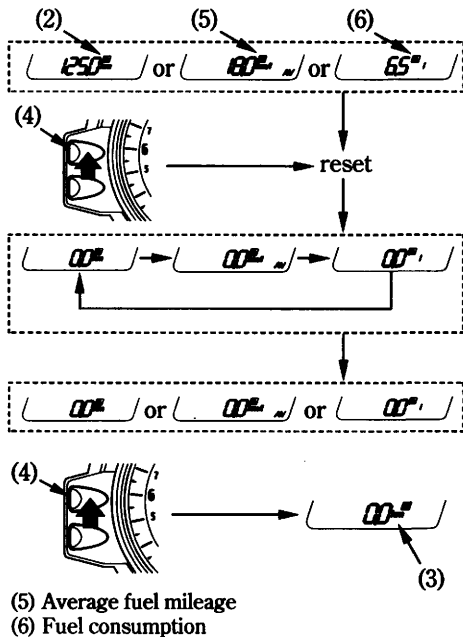

Fuel Mileage Meter

The fuel mileage meter includes the following functions:

- Current fuel mileage
- Average fuel mileage
- Fuel consumption

The indication mode of the current and average fuel mileage can be selected km/l and l/100 km (page 35).

< E type only >

The unit of the indication depends on the unit which you select (page 34).

When the odometer (5) or tripmeter A (6) is displayed, press control button B (7) to select any mode of the fuel mileage meter. Press control button A (8) to change the indication to the odometer or tripmeter A.

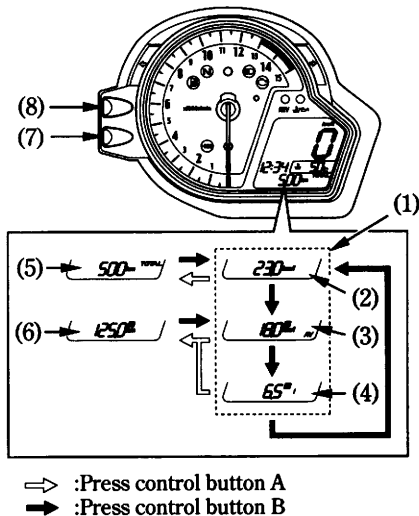

- | | |
|--------------------------|----------------------|
| (1) Fuel mileage meter | (5) Odometer |
| (2) Current fuel mileage | (6) Tripmeter A |
| (3) Average fuel mileage | (7) Control button B |
| (4) Fuel consumption | (8) Control button A |

Current fuel mileage:

This display shows the current, or instant fuel mileage you are getting.

When your motorcycle speed is 1 km/h (0.6 mph) or below, “— — .—” is displayed.

Average fuel mileage:

This number is updated once per 15 seconds since you last reset the tripmeter A. When “— — .—” is displayed, go to your Honda dealer for service.

Fuel consumption:

This display shows the fuel consumption since you last reset the tripmeter A.

When “— — — .—” is displayed, go to your Honda dealer for service.

To reset average fuel mileage and fuel consumption:

When the tripmeter A is reset, the average fuel mileage and fuel consumption are reset together (page 30).

Also, after refueling more than the reserve amount, the tripmeter A, average fuel mileage, and fuel consumption can be automatically reset.

You can activate or deactivate the automatic reset mode by refueling (page 33).

To activate/deactivate the automatic reset mode:

You can activate or deactivate the automatic reset by refueling mode.

Initial setting is deactivated.

1. Press and hold control button B (1), and turn on the ignition switch. Keep control button B pressed until the lower segment (2) of the multi-function display starts to blink.

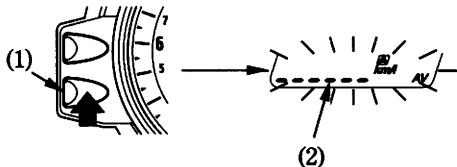

- (1) Control button B
- (2) Lower segment

2. Press control button A (3) to activate or deactivate the automatic reset mode.

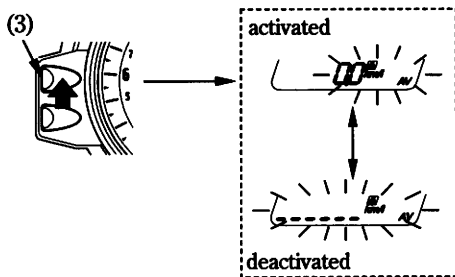

- (3) Control button A
3. To end the selection, press control button B. The display will return to the ordinary conditions.

The display will stop blinking automatically and return to the ordinary conditions if the button is not pressed for about 30 seconds. As you turn off the ignition switch during the presetting procedures, the preset data just before turning off the ignition switch will be registered.

Speed, Mileage and Fuel Mileage Unit Change

< E type only >

The speedometer can display "km/h" or "mph".

The odometer/tripmeter can also display "km" or "mile".

The fuel mileage meter can display "l" or "gal".

1. Turn the ignition switch ON.
2. Press and hold both control button A (1) and control button B (2) for more than 2 seconds.

The unit you are setting in the multi-function display starts to blink.

3. Press control button A to select "km"/"km/h"/"l" or "mile"/"mph"/"gal".

4. To end the selection, press control button B.

The display will stop blinking automatically if the button is not pressed for about 30 seconds.

As you turn off the ignition switch during the presetting procedures, the preset data just before turning off the ignition switch will be registered.

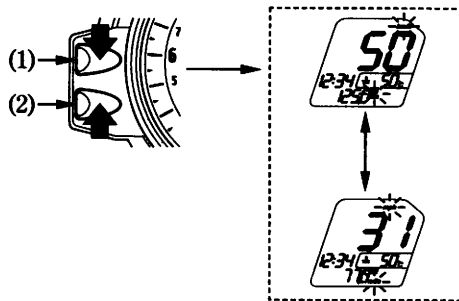

(1) Control button A

(2) Control button B

Indication Mode of Fuel Mileage Change

When the speedometer is displayed in "km/h", either "km/l" or "l/100 km" can be the set unit for current and average fuel mileage.

If the ordinary indication is tripmeter B, fuel consumption or reserve fuel consumption, this function becomes invalid, and returns to the ordinary indication.

< E type only >

This function can be operated after the speed, mileage, and fuel mileage units are selected.

1. < except E type >

Turn the ignition switch ON, and press and hold control button A (1) and B (2) for more than 2 seconds.

The unit you are setting in the multi-function display starts to blink.

2. Press control button A to select "km/l" or "l/100 km".

If the ordinary indication is the odometer or tripmeter A, it automatically changes to current or average fuel mileage.

3. To end the selection, press control button B.

The display will stop blinking automatically if the button is not pressed for about 30 seconds.

As you turn off the ignition switch during the presetting procedures, the preset data just before turning off the ignition switch will be registered.

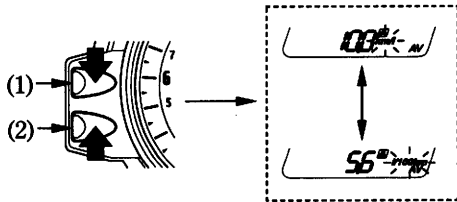

(1) Control button A

(2) Control button B

Digital Clock

Shows hour and minute. To adjust the time, proceed as follows:

1. Turn the ignition switch ON.
2. Press and hold control button B (2) for more than 2 seconds. The clock will be set in the adjust mode with the display blinking.

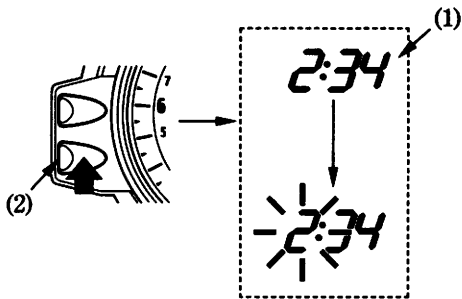

- (1) Digital clock
(2) Control button B

3. To set the hour, press control button A (3) until the desired hour is displayed.
 - The time is advanced by one hour each time the button is pressed.
 - The time advances fast when the button is pressed and held.

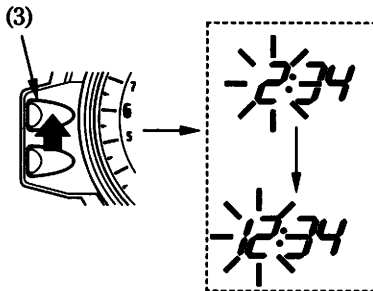

- (3) Control button A

4. Press control button B. The minute display will start blinking.

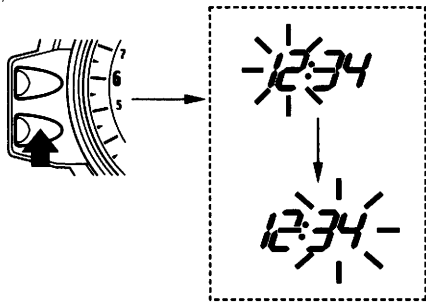

5. To set the minute, press control button A until the desired minute. The minute display will return to "00" when "60" is reached without affecting the hour display.

- The time advances by one minute, each time the button is pressed.
- The time advances fast when the button is pressed and held.

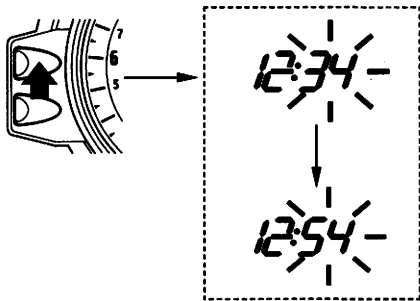

6. To end the adjustment, press control button B or turn the ignition switch OFF. The display will stop flashing automatically and the adjustment will be cancelled if the button is not pressed for about 30 seconds.

The clock will be reset 1:00 if the battery is disconnected.

Presetting of Tachometer Red Zone (REV) Indicator Activation Revolution and Indication Pattern

The REV indicator activation revolution and the indication pattern can be altered for your choice.

To set the REV indicator activation revolution:

〈Except F type〉

The original red zone revolution can be selected in 2,000 rpm-to-13,000 rpm range.

〈F type only〉

The original red zone revolution can be selected in 2,000 rpm-to-12,000 rpm range.

1. Press and hold control button A (1), turn on the ignition switch. Keep control button A pressed in until the initial display is completed.

The tachometer needle moves to the set-up revolutions.

2. Each time you press control button A, the tachometer needle (2) will move by an increment of 500 rpm.

By pushing and holding control button A for more than 1 second, the tachometer needle will move by an increment of 1,000 rpm.

As the revolution goes beyond the allowable range, the needle will automatically return to 2,000 rpm.

After completing the original red zone revolution preset, press control button B (3), and proceed to the indication pattern presetting.

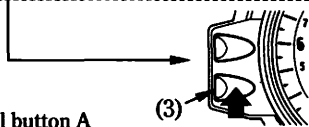
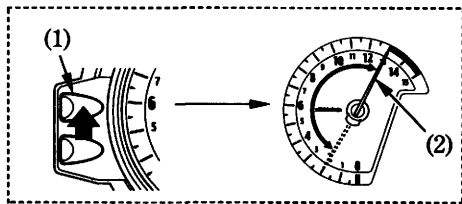

- (1) Control button A
- (2) Tachometer needle
- (3) Control button B

To select the REV indicator indication pattern:

An indication pattern can be selected from the 9 patterns (page 40).

The indication pattern will be set each time you press control button A (1), to select a pattern you like.

To end the setting, press control button B (2).

As you turn off the ignition switch during the presetting procedures, the preset data just before turning off the ignition switch will be registered.

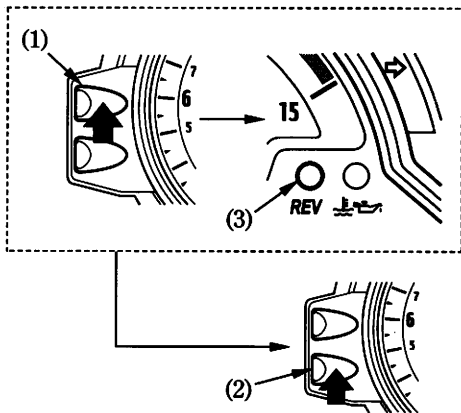

- (1) Control button A
- (2) Control button B
- (3) REV indicator

Indication pattern

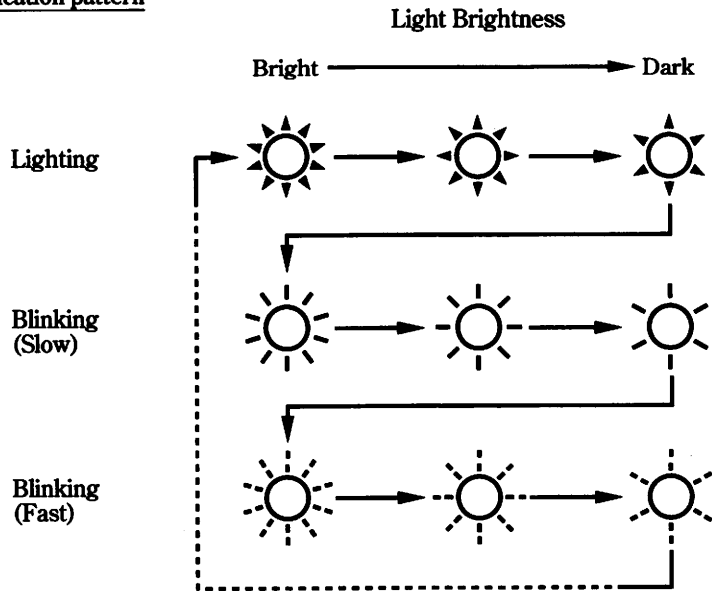

MAJOR COMPONENTS

(Information you need to operate this motorcycle)

SUSPENSION

Front Suspension

Spring Preload:

Adjust the spring preload by turning the spring preload adjuster with the 19 mm wrench provided in the tool kit (page 101).

To reduce (SOFT) :

Turn the adjuster counterclockwise toward SOFT for a light load and smooth road condition.

To increase (HARD) :

Turn the adjuster clockwise toward HARD for a firmer ride and rough road condition.

To adjust the adjuster to the standard position, proceed as follows :

1. Turn the spring preload adjuster (1) counterclockwise until it will no longer turn (lightly seats). This is the full soft setting.
2. The adjuster is set in the standard position when the adjuster is turned clockwise 6 turns.
3. Make sure that both fork legs are adjusted to the same position.

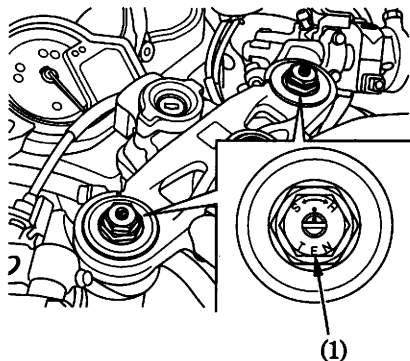

(1) Spring preload adjuster

Rebound Damping:

To reduce (SOFT) :

Turn the adjuster counterclockwise toward SOFT for a light load and smooth road condition.

To increase (HARD) :

Turn the adjuster clockwise toward HARD for a firmer ride and rough road condition.

To adjust the adjuster to the standard position, proceed as follows :

1. Turn the damping adjuster (1) clockwise until it will no longer turn (lightly seats). This is the full hard setting.
2. The adjuster is set in the standard position when the adjuster is turned counterclockwise approximately $2\frac{1}{4}$ turns so that its punch mark (2) aligns with the reference mark (3).
3. Make sure that both fork legs are adjusted to the same position.

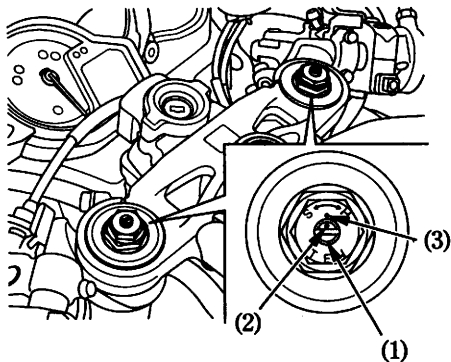

- (1) Damping adjuster
- (2) Punch mark
- (3) Reference punch mark

Compression Damping:

To reduce (SOFT) :

Turn the adjuster counterclockwise toward SOFT for a light load and smooth road condition.

To increase (HARD) :

Turn the adjuster clockwise toward HARD for a firmer ride and rough road condition.

To adjust the adjuster to the standard position, proceed as follows :

1. Turn the damping adjuster (1) clockwise until it will no longer turn (lightly seats). This is the full hard setting.
2. The adjuster is set in the standard position when the adjuster is turned counterclockwise approximately 2 turns so that its punch mark (2) aligns with the reference punch mark (3).
3. Make sure that both fork legs are adjusted to the same position.

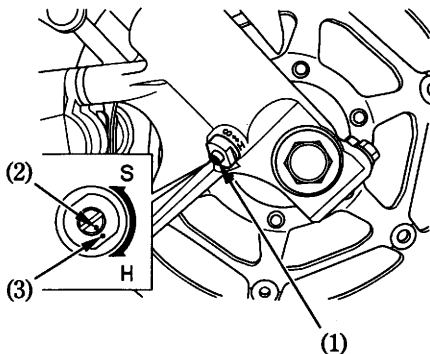

(1) Damping adjuster
(2) Punch mark

(3) Reference punch
mark

Rear Suspension Rebound Damping:

To reduce (SOFT) :

Turn the adjuster counterclockwise toward SOFT for a light load and smooth road condition.

To increase (HARD) :

Turn the adjuster clockwise toward HARD for a firmer ride and rough road condition.

To adjust the adjuster to the standard position, proceed as follows :

1. Turn the damping adjuster (1) clockwise until it will no longer turn (lightly seats). This is the full hard setting.
2. The adjuster is set in the standard position when the adjuster is turned counterclockwise approximately 2 turns so that its punch mark (2) aligns with the reference punch mark (3).

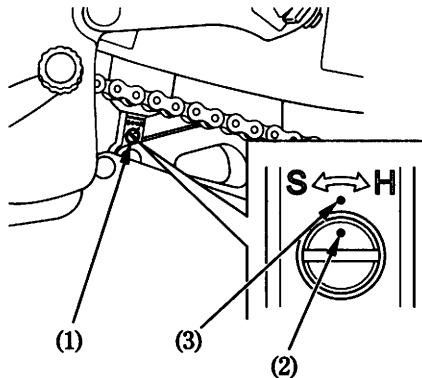

(1) Damping adjuster

(2) Punch mark

(3) Reference punch mark

mark

Compression Damping:

To reduce (SOFT) :

Turn the adjuster counterclockwise toward SOFT for a light load and smooth road condition.

To increase (HARD) :

Turn the adjuster clockwise toward HARD for a firmer ride and rough road condition.

To adjust the adjuster to the standard position, proceed as follows :

1. Turn the damping adjuster (1) clockwise until it will no longer turn (lightly seats). This is the full hard setting.
2. The adjuster is set in the standard position when the adjuster is turned counterclockwise approximately 2 turns so that its punch mark (2) aligns with the reference punch mark (3).

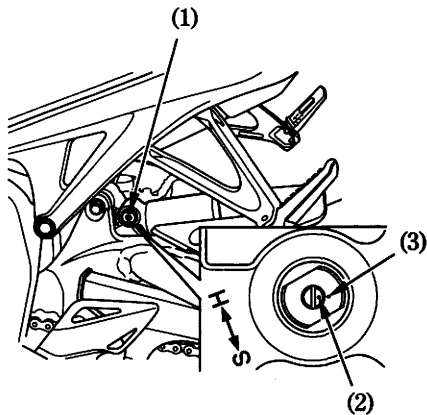

(1) Damping adjuster
(2) Punch mark

(3) Reference punch
mark

Spring Preload:

The spring preload adjuster (1) has 10 spring preload positions for different load or riding conditions.

Use the pin spanner (2) and extension bar (3) to adjust the rear shock.

Positions 1 to 3 are for a light load and smooth road conditions. Position 4 is the standard position. Positions 5 to 10 increase spring preload for a stiffer rear suspension and can be used when the motorcycle is more heavily loaded.

The rear shock absorber assembly includes a damper unit that contains high pressure nitrogen gas. Do not attempt to disassemble or service the damper; it cannot be rebuilt and must be replaced when worn out. Disposal should only be done by your Honda dealer. The instructions found in this owner's manual are limited to adjustment of the shock assembly only.

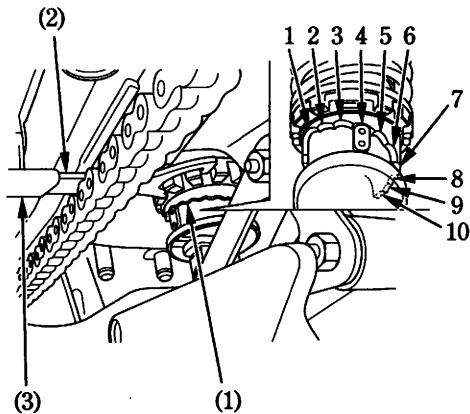

- (1) Spring preload adjuster
- (2) Pin spanner
- (3) Extension bar

BRAKES

Both the front and rear brakes are the hydraulic disc types.

As the brake pads wear, the brake fluid level drops.

There are no adjustments to perform, but fluid level and pad wear must be inspected periodically. The system must be inspected frequently to ensure there are no fluid leaks. If the control lever or pedal free travel becomes excessive and the brake pads are not worn beyond the recommended limit (page 127), there is probably air in the brake system and it must be bled. See your Honda dealer for this service.

Front Brake Fluid Level:

With the motorcycle in an upright position, check the fluid level. It should be between the UPPER (1) and LOWER (2) level marks. If the level is at or below the LOWER level mark, check the front brake pads for wear (page 127).

Worn pads should be replaced. If the pads are not worn, have your brake system inspected for leaks.

The recommended brake fluid is Honda DOT 4 brake fluid from a sealed container, or an equivalent.

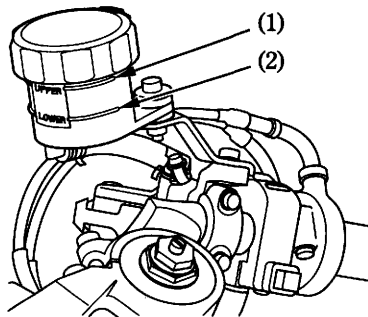

- (1) UPPER level mark
- (2) LOWER level mark

Front Brake Lever:

The distance between the tip of the brake lever (1) and the grip can be adjusted by turning the adjuster dial (2) while pushing the lever forward.

Align the numbers (3) on the adjuster dial with the index mark (4).

Apply the brake several times and check for free wheel rotation after the brake lever is released.

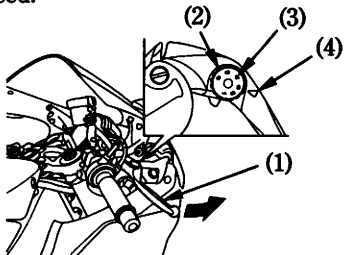

- (1) Brake lever
- (2) Adjuster dial

- (3) Numbers
- (4) Index mark

Other Checks:

Make sure there are no fluid leaks. Check for deterioration or cracks in the hoses and fittings.

Rear Brake Fluid Level:

With the motorcycle in an upright position, check the fluid level. It should be between the UPPER (1) and LOWER (2) level marks. If the level is at or below the LOWER level mark (2), check the brake pads for wear (page 128).

Worn pads should be replaced. If the pads are not worn, have your brake system inspected for leaks.

The recommended brake fluid is Honda DOT 4 brake fluid from a sealed container, or an equivalent.

Other Checks:

Make sure there are no fluid leaks. Check for deterioration or cracks in the hoses and fittings.

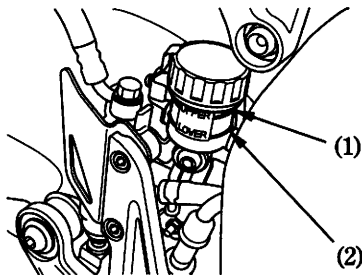

- (1) UPPER level mark
- (2) LOWER level mark

CLUTCH

Clutch adjustment may be required if the motorcycle stalls when shifting into gear or tends to creep; or if the clutch slips, causing acceleration to lag behind engine speed. Minor adjustments can be made with the clutch cable adjuster (2) at the clutch lever (1).

Normal clutch lever freeplay is:
10–20 mm (0.4–0.8 in)

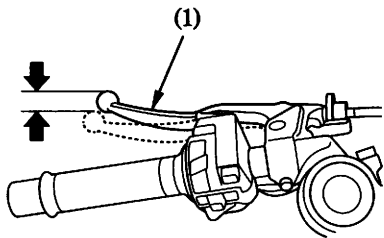

(1) Clutch lever

1. Turn the adjuster and check the adjustment.
2. If the adjuster is threaded out near its limit or if the correct freeplay cannot be obtained, turn in the cable adjuster completely.

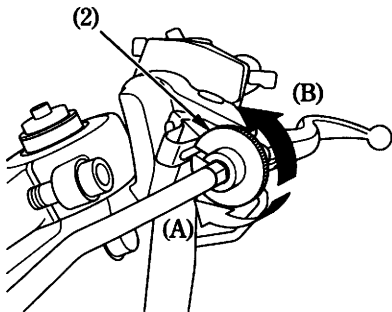

(2) Clutch cable adjuster (A) Increase freeplay
(B) Decrease freeplay

3. Remove the lower cowl (page 81).
4. Remove the screw (3) on the right middle cowl (4) and pull it outwards.

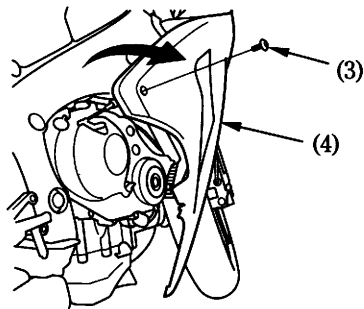

- (3) Screw
 (4) Middle cowl

5. Loosen the lock nut (5) at the lower end of the cable. Turn the adjusting nut (6) to obtain the specified freeplay. Tighten the lock nut and check the adjustment.
6. Install the right middle cowl with screw.
7. Install the lower cowl (page 81).

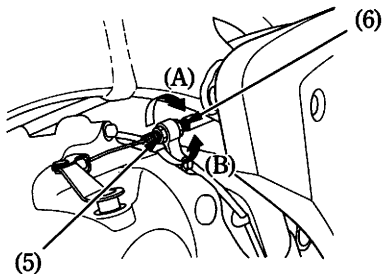

- (5) Lock nut
 (6) Adjusting nut
 (A) Increase freeplay
 (B) Decrease freeplay

8. Start the engine, pull in the clutch lever and shift into gear. Make sure the engine does not stall and the motorcycle does not creep. Gradually release the clutch lever and open the throttle. The motorcycle should begin to move smoothly and accelerate gradually.

If proper adjustment cannot be obtained or the clutch does not work correctly, see your Honda dealer.

Other Checks:

Check the clutch cable for kinks or signs of wear that could cause sticking or failure. Lubricate the clutch cable with a commercially available cable lubricant to prevent premature wear and corrosion.

COOLANT

Coolant Recommendation

The owner must properly maintain the coolant to prevent freezing, overheating, and corrosion. Use only high quality ethylene glycol antifreeze containing corrosion protection inhibitors specifically recommended for use in aluminum engines. (SEE ANTIFREEZE CONTAINER LABEL).

Use only low-mineral drinking water or distilled water as a part of the antifreeze solution. Water that is high in mineral content or salt may be harmful to the aluminum engine.

Using coolant with silicate inhibitors may cause premature wear of water pump seals or blockage of radiator passages.

Using tap water may cause engine damage.

The factory provides a 50/50 solution of antifreeze and distilled water in this motorcycle. This coolant solution is recommended for most operating temperatures and provides good corrosion protection. A higher concentration of antifreeze decreases the cooling system performance and is recommended only when additional protection against freezing is needed. A concentration of less than 40/60 (40% antifreeze) will not provide proper corrosion protection. During freezing temperatures, check the cooling system frequently and add higher concentrations of antifreeze (up to a maximum of 60% antifreeze) if required.

Inspection

The reserve tank is behind the rear brake fluid reservoir.

Check the coolant level in the reserve tank (1) while the engine is at the normal operating temperature with the motorcycle in an upright position. If the coolant level is below the LOWER level mark (3), remove the reserve tank cap (4) and add coolant mixture until it reaches the UPPER level mark (2). Always add coolant to the reserve tank.

Do not attempt to add coolant by removing the radiator cap.

If the reserve tank is empty, or if coolant loss is excessive, check for leaks and see your Honda dealer for repair.

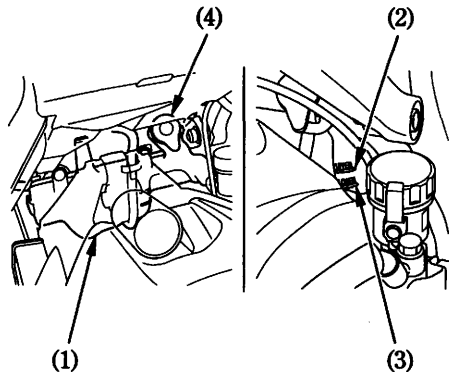

(1) Reserve tank

(2) UPPER level mark

(3) LOWER level mark

(4) Reserve tank cap

FUEL

Fuel Tank

The fuel tank capacity including the reserve supply is:

17.7 ℓ (4.68 US gal , 3.89 Imp gal)

To open the fuel fill cap (1), insert the ignition key (2) and turn it clockwise. The fuel fill cap is hinged and will lift up.

Do not overfill the tank. There should be no fuel above the level plate (3).

After refueling, to close the fuel fill cap, push the fuel fill cap into the filler neck until it snaps closed and locks. Remove the key.

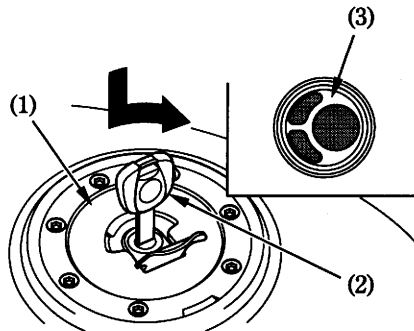

⚠ WARNING

Petrol is highly flammable and explosive. You can be burned or seriously injured when handling fuel.

- Stop the engine and keep heat, sparks, and flame away.
- Refuel only outdoors.
- Wipe up spills immediately.

(1) Fuel fill cap
(2) Ignition key

(3) Level plate

Use unleaded petrol with a research octane number of 95 or higher.

The use of leaded petrol will cause premature damage to the catalytic converters.

NOTICE

If “spark knock” or “pinking” occurs at a steady engine speed under normal load, change brands of petrol. If spark knock or pinking persists, consult your Honda dealer. Failure to do so is considered misuse, and damage caused by misuse is not covered by Honda’s Limited Warranty.

Petrol Containing Alcohol

If you decide to use a petrol containing alcohol (gasohol), be sure it's octane rating is at least as high as that recommended by Honda. There are two types of "gasohol": one containing ethanol, and the other containing methanol. Do not use petrol that contains more than 10 % ethanol. Do not use petrol containing methanol (methyl or wood alcohol) that does not also contain cosolvents and corrosion inhibitors for methanol. Never use petrol containing more than 5 % methanol, even if it has cosolvents and corrosion inhibitors.

Fuel system damage or engine performance problems resulting from the use of fuels that contain alcohol is not covered under the warranty. Honda cannot endorse the use of fuels containing methanol since evidence of their suitability is as yet incomplete.

Before buying fuel from an unfamiliar station, try to find out if the fuel contains alcohol. If it does, confirm the type and percentage of alcohol used. If you notice any undesirable operating symptoms while using a petrol that contains alcohol, or one that you think contains alcohol, switch to a petrol that you know does not contain alcohol.

ENGINE OIL

Engine Oil Level Check

Check the engine oil level each day before riding the motorcycle.

The level must be maintained between the upper (1) and lower (2) level marks on the dipstick (3).

1. Start the engine and let it idle for 3–5 minutes. Make sure the low oil pressure indicator goes off. If the indicator light remains on, stop the engine immediately.
2. Stop the engine and hold the motorcycle in an upright position on firm, level ground.
3. After 2–3 minutes, remove the dipstick, wipe it clean, and reinsert the dipstick without screwing it in. Remove the dipstick. The oil level should be between the upper and lower marks on the dipstick.

4. If required, remove the oil filler cap (4) and add the specified oil (page104) up to the upper level mark. Do not overfill.
5. Reinstall the dipstick and oil filler cap. Check for oil leaks.

NOTICE

Running the engine with insufficient oil pressure may cause serious engine damage.

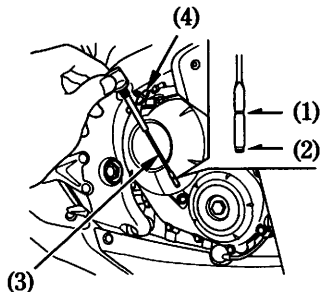

- | | |
|----------------------|--------------------|
| (1) Upper level mark | (3) Dipstick |
| (2) Lower level mark | (4) Oil filler cap |

TUBELESS TYRES

To safely operate your motorcycle, your tyres must be the proper type and size, in good condition with adequate tread, and correctly inflated for the load you are carrying. The following pages give more detailed information on how and when to check your air pressure, how to inspect your tyres for damage, and what to do when your tyres need to be repaired or replaced.

▲ WARNING

Using tyres that are excessively worn or improperly inflated can cause a crash in which you can be seriously hurt or killed.

Follow all instructions in this owner's manual regarding tyre inflation and maintenance.

Air Pressure

Keeping your tyres properly inflated provides the best combination of handling, tread life and riding comfort. Generally, underinflated tyres wear unevenly, adversely affect handling, and are more likely to fail from being overheated.

Overinflated tyres make your motorcycle ride harshly, are more prone to damage from road hazards, and wear unevenly.

We recommend that you visually check your tyres before every ride and use a gauge to measure air pressure at least once a month or any time you think the tyres might be low.

Tubeless tyres have some self-sealing ability if they are punctured. However, because leakage is often very slow, you should look closely for punctures whenever a tyre is not fully inflated.

Always check air pressure when your tyres are “cold” – when the motorcycle has been parked for at least three hours. If you check air pressure when your tyres are “warm” – when the motorcycle has been ridden for even a few miles – the readings will be higher than if the tyres were “cold”. This is normal, so do not let air out of the tyres to match the recommended cold air pressures given below. If you do, the tyres will be underinflated.

The recommended “cold” tyre pressures are:

Front	250 kPa (2.50 kgf/cm ² , 36 psi)
Rear	290 kPa (2.90 kgf/cm ² , 42 psi)

Inspection

Whenever you check the tyre pressures, you should also examine the tyre treads and sidewalls for wear, damage, and foreign objects:

Look for:

- Bumps or bulges in the side of the tyre or the tread. Replace the tyre if you find any bumps or bulges.
- Cuts, splits or cracks in the tyre. Replace the tyre if you can see fabric or cord.
- Excessive tread wear.

Also, if you hit a pothole or hard object, pull to the side of the road as soon as you can safely and carefully inspect the tyres for damage.

Tread Wear

Replace tyres before tread depth at the center of the tyre reaches the following limit:

Minimum tread depth	
Front:	1.5 mm (0.06 in)
Rear:	2.0 mm (0.08 in)

< For Germany >

German law prohibits use of tyres whose tread depth is less than 1.6 mm.

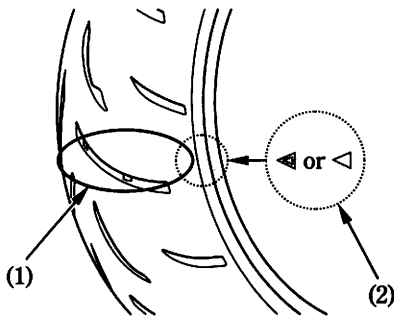

- (1) Wear indicator
- (2) Wear indicator location mark

Tyre Repair

If a tyre is punctured or damaged, you should replace it, not repair it. As discussed below, a tyre that is repaired, either temporarily or permanently, will have lower speed and performance limits than a new tyre.

A temporary repair, such as an external tubeless tyre plug, may not be safe for normal speeds and riding conditions. If a temporary or emergency repair is made to a tyre, you should ride slowly and cautiously to a dealer and have the tyre replaced. If possible, you should not carry a passenger or cargo until a new tyre is installed.

Even if a tyre is professionally repaired with a permanent internal patch plug, it will not be as good as a new tyre. You should not exceed 80 km/h (50 mph) for the first 24 hours, or 130 km/h (80 mph) at any time thereafter. In addition, you may not be able to safely carry as much weight as with a new tyre. Therefore, we strongly recommend that you replace a damaged tyre. If you choose to have a tyre repaired, be sure the wheel is balanced before you ride.

Tyre Replacement

The tyres that came on your motorcycle were designed to match the performance capabilities of your motorcycle and provide the best combination of handling, braking, durability and comfort.

⚠ WARNING

Installing improper tyres on your motorcycle can affect handling and stability. This can cause a crash in which you can be seriously hurt or killed.

Always use the size and type of tyres recommended in this owner's manual.

The recommended tyres for your motorcycle are:

Front: 120/70ZR17M/C(58W)
BRIDGESTONE
BT015F RADIAL F
DUNLOP
Qualifier PTK

Rear: 190/50ZR17M/C(73W)
BRIDGESTONE
BT015R RADIAL F
DUNLOP
Qualifier NK

Type: radial, tubeless

Whenever you replace a tyre, use one that is equivalent to the original and be sure the wheel is balanced after the new tyre is installed.

Important Safety Reminders

- Do not install a tube inside a tubeless tyre on this motorcycle. Excessive heat build-up can cause the tube to burst.
- Use only tubeless tyres on this motorcycle. The rims are designed for tubeless tyres, and during hard acceleration or braking, a tube-type tyre could slip on the rim and cause the tyre to rapidly deflate.

ESSENTIAL INDIVIDUAL COMPONENTS

IGNITION SWITCH

The ignition switch (1) is below the indicator panel.

The headlight, position light, taillights and license light will come on whenever you turn the ignition switch ON. If your motorcycle is stopped with the ignition switch ON and the engine is not running, the headlight, position light, taillights and license light will still be on, resulting in battery discharge.

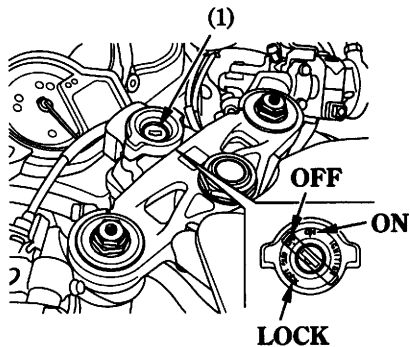

(1) Ignition switch

Key Position	Function	Key Removal
LOCK (steering lock)	Steering is locked. Engine and lights cannot be operated.	Key can be removed
OFF	Engine and lights cannot be operated.	Key can be removed
ON	Engine and lights can be operated.	Key cannot be removed

KEYS

This motorcycle has two keys and a key number plate.

You will need the key number if you ever have to replace a key. Store the plate in a safe place.

To reproduce keys, bring all keys, key number plate and motorcycle to your Honda dealer.

Up to four keys can be registered with the immobilizer system (HISS), including the ones in hand.

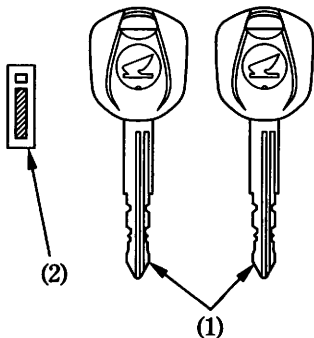

(1) Keys

(2) Key number plate

If all keys are lost, the PGM-FI unit/ignition control module must be replaced. To avoid this possibility we recommend that if only one key is left, you immediately have it reproduced to ensure that a back-up is available.

These keys contain electronic circuits that are activated by the immobilizer system (HISS). They will not work to start the engine if the circuits are damaged.

- Do not drop the keys or set heavy objects on them.
- Do not grind, drill or in any way alter the original shape of the keys.
- Keep the keys away from magnetic objects.

IMMOBILIZER SYSTEM (HISS)

HISS is the abbreviation of Honda Ignition Security System.

The immobilizer system (HISS) protects your motorcycle from theft. A properly-coded key must be used in the ignition switch for the engine to start. If an improperly-coded key (or other device) is used the engine's starting circuit is disabled.

When the ignition switch is turned ON, the immobilizer system (HISS) indicator lights for a few seconds, then goes off. If the indicator remains on, it means the system does not recognize the coding of the key. Turn the ignition switch to OFF, remove the key, reinsert and turn the switch ON again.

The immobilizer system has such a function that keeps the immobilizer system (HISS) indicator blinking at 2 second intervals for 24 hours. This blinking function can be turned on or off.

To turn the blinking function on or off:

1. Turn the ignition switch ON.
2. When the odometer is displayed (page 27), push and hold control button A (2) for more than 2 seconds.

The immobilizer system (HISS) indicator (1) comes on briefly and the blinking function is set to on or off.

3. Turn the ignition switch OFF and remove the key.

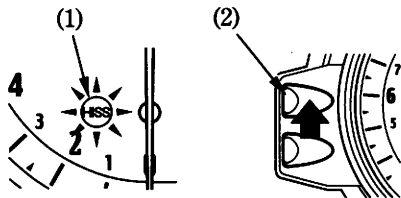

- (1) Immobilizer system (HISS) indicator
(2) Control button A

If the system repeatedly does not recognize the coding of your key, contact your Honda dealer.

- The system may not recognize the key's coding if any other immobilizer key is near the ignition switch. To make sure the system recognizes the key code, keep each immobilizer key on a separate ring.
- Do not attempt to alter the immobilizer system (HISS) or add other devices to it. Electrical problems could result, making it impossible to start your motorcycle.
- If all keys are lost, the PGM-FI unit/ignition control module must be replaced.

EC Directives

This immobilizer system complies with the R & TTE (Radio equipment and telecommunications terminal equipment and the mutual recognition of their conformity) Directive.





The declaration of conformity to R & TTE Directive is provided to the owner at the time of purchase. The declaration of conformity should be kept at a safe place. When the declaration of conformity is lost or is not provided, contact your Honda dealer.

<South Africa only>



RIGHT HANDLEBAR CONTROLS

Engine Stop Switch

The engine stop switch (1) is next to the throttle grip. When the switch is in the  (RUN) position, the engine will operate. When the switch is in the  (OFF) position, the engine will not operate. This switch is intended primarily as a safety or emergency switch and should normally remain in the  (RUN) position.

If your motorcycle is stopped with the ignition switch ON and the engine stop switch  (OFF), the headlight, position light, taillights and license light will still be on, resulting in battery discharge.

Start Button

The start button (2) is below the engine stop switch.

The start button is used for starting the engine. Pushing the button in starts the engine. See Starting Procedure, page 87 . When the start button is pushed, the starter motor will crank the engine, the headlight will automatically go out, but the position light, taillights and license light will stay on.

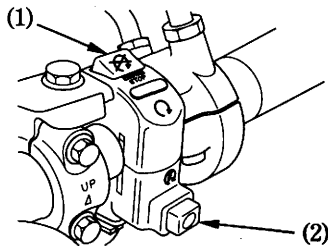

- (1) Engine stop switch
- (2) Start button

LEFT HANDLEBAR CONTROLS

Headlight Dimmer Switch (1)

The headlight dimmer switch is used to change between the high and low beams of the headlight. To operate, turn the switch to ☰ (HI) for high beam, ☷ (LO) for low beam.

Passing Light Control Switch (2)

When this switch is pressed, the headlight flashes on to signal approaching cars or when passing.

Turn Signal Switch (3)

Move to ⇐ (L) to signal a left turn, ⇒ (R) to signal a right turn. Press to turn signal off.

Horn Button (4)

Press the button to sound the horn.

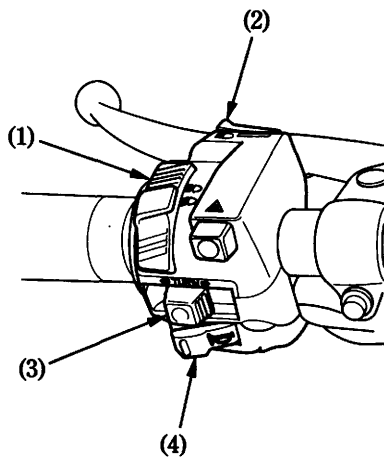

- (1) Headlight dimmer switch
- (2) Passing light control switch
- (3) Turn signal switch
- (4) Horn button

Hazard Switch (5)

The Hazard should be used only when your motorcycle is stopped under emergency or hazardous conditions. To turn it on, turn the ignition key to the ON position, and then push the switch marked . The front and rear turn signals will blink simultaneously.

All of the signals can blink without the ignition key.

To operate this function, proceed as follows:

1. Turn the ignition key to ON position and then push the hazard switch.
2. All of the turn signals will keep blinking even after you turn the ignition key to OFF position.
3. You can turn off the turn blinking signals by pushing the hazard switch again to the off position.

Be sure to turn the switch off when the hazard warning is no longer required, or the turn signals will not work properly, and may confuse other drivers.

If all the turn signals are left blinking with the engine stopped, the battery will be discharged.

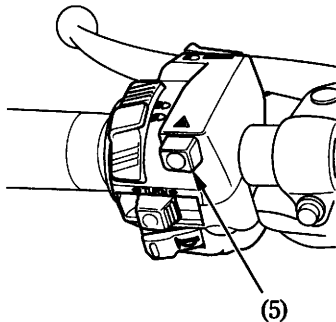

(5) Hazard switch

HESD (Honda Electronic Steering Damper)

This motorcycle is equipped with the electronically-controlled steering damper. The HESD (1) automatically controls the steering damper characteristics in accordance with vehicle speed and acceleration.

The HESD indicator (2) lights when there is any abnormality in the HESD. The HESD indicator should also go on for a few seconds and then go off when the ignition switch is turned ON.

If the HESD indicator lights at any time, reduce speed and take the motorcycle to your Honda dealer as soon as possible.

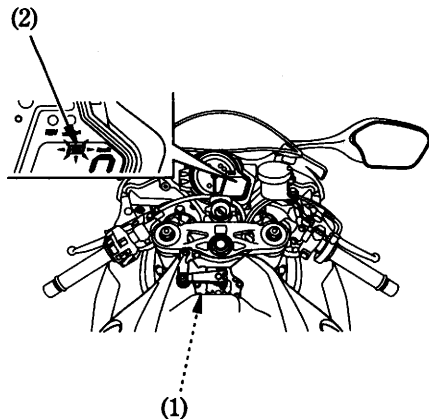

- (1) HESD
- (2) HESD indicator