

 **HONDA**

**OWNER'S MANUAL
USO E MANUTENZIONE
MANUAL DEL PROPIETARIO**

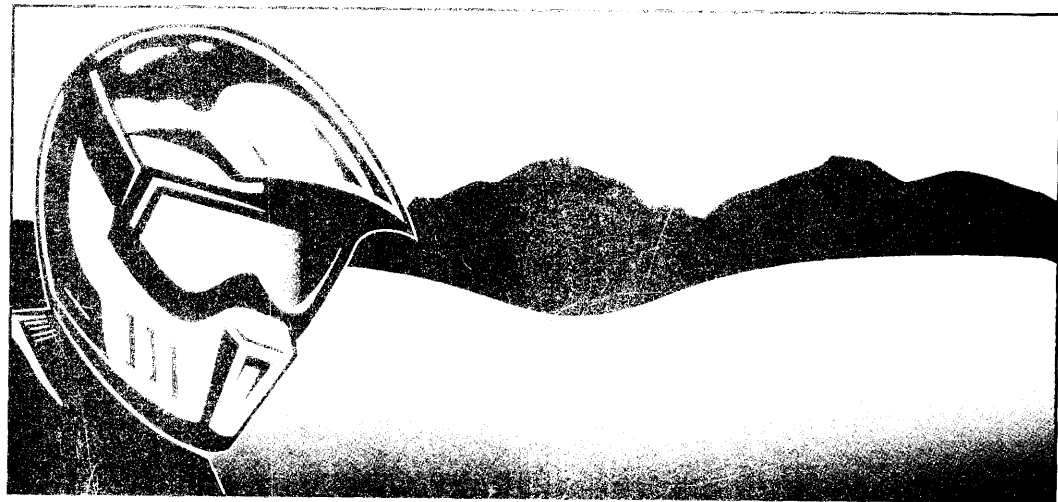

CRF70F

Honda CRF70F

OWNER'S MANUAL

USO E MANUTENZIONE

MANUAL DEL PROPIETARIO

IMPORTANT INFORMATION

- **OPERATOR ONLY. NO PASSENGER**

This motorcycle is designed and constructed as an operator-only model. The seating configuration does not safely permit the carrying of a passenger. Do not exceed the maximum weight capacity.

- **FOR OFF-ROAD USE ONLY**

This motorcycle is designed and manufactured for off-road use only.

- **PARENTS : READ IMPORTANT MESSAGE ON PAGE 1 .**

- **READ THIS OWNER'S MANUAL CAREFULLY**

Pay special attention to the safety messages that appear throughout the manual. These messages are fully explained in the "A Few Words About Safety" section which appears before the Contents page.

This manual should be considered a permanent part of the motorcycle and should remain with the motorcycle when resold.

Honda CRF70F OWNER'S MANUAL

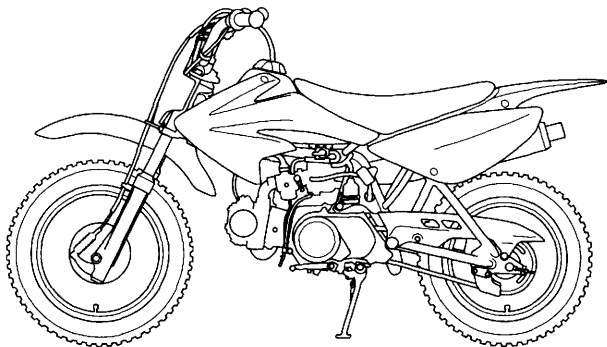

All information in this publication is based on the latest production information available at the time of approval for printing. Honda Motor Co.,Ltd. reserves the right to make changes at any time without notice and without incurring any obligation.

No part of this publication may be reproduced without written permission.

WELCOME

Your new motorcycle presents you with an invitation to adventure and a challenge to master the machine. Your safety depends not only on your own alertness and familiarity with the motorcycle, but also the motorcycle's mechanical condition. A pre-ride inspection before every outing and regular maintenance are essential.

To help meet the challenges safely and enjoy the adventure fully, become thoroughly familiar with this Owner's Manual **BEFORE YOU RIDE THE MOTORCYCLE**.

As you read this manual, you will find information that is preceded by a **NOTICE** symbol. This information is intended to help you avoid damage to your motorcycle, other property, or the environment.

When service is required, remember that your Honda dealer knows your motorcycle best. If you have the required mechanical "know-how" and tools, your dealer can supply you with an official Honda Shop Manual to help you perform many maintenance and repair tasks.

Pleasant riding, and thank you for choosing a Honda!

- The following codes in this manual indicate each country.

ED	(Europe)
U	Australia

- The specifications may vary with each locale.

A FEW WORDS ABOUT SAFETY

Your safety, and the safety of others, is very important. And operating this motorcycle safely is an important responsibility.

To help you make informed decisions about safety, we have provided operating procedures and other information on labels and in this manual. This information alerts you to potential hazards that could hurt you or others.

Of course, it is not practical or possible to warn you about all hazards associated with operating or maintaining a motorcycle. You must use your own good judgment.

You will find important safety information in a variety of forms, including:

- **Safety Labels** — on the motorcycle.
- **Safety Messages** — preceded by a safety alert symbol  and one of three signal words: **DANGER, WARNING, or CAUTION.**

These signal words mean:

▲ DANGER

You **WILL** be **KILLED** or **SERIOUSLY HURT** if you don't follow instructions.

▲ WARNING

You **CAN** be **KILLED** or **SERIOUSLY HURT** if you don't follow instructions.

▲ CAUTION

You **CAN** be **HURT** if you don't follow instructions.

- **Safety Headings** — such as Important Safety Reminders or Important Safety Precautions.
- **Safety Section** — such as Motorcycle Safety.
- **Instructions** — how to use this motorcycle correctly and safely.

This entire manual is filled with important safety information — please read it carefully.

OPERATION

page

- 1 MOTORCYCLE SAFETY**
- 1 IMPORTANT MESSAGE TO PARENTS
- 3 IMPORTANT SAFETY INFORMATION
- 5 PROTECTIVE APPAREL
- 7 LOAD LIMITS AND GUIDELINES
- 11 SAFETY LABELS

12 PARTS LOCATION

15 MAJOR COMPONENTS

(Information you need to operate this motorcycle)

- 15 BRAKES
- 20 CLUTCH
- 21 FUEL
- 25 ENGINE OIL
- 26 TYRES

page

- 31 ESSENTIAL INDIVIDUAL COMPONENTS**
- 31 IGNITION SWITCH
- 32 ENGINE STOP SWITCH

page

33 FEATURES

(Not required for operation)

33 SEAT

34 SIDE COVER

page

35 OPERATION

35 PRE-RIDE INSPECTION

37 STARTING THE ENGINE

40 RUNNING-IN

41 RIDING

43 HIGH ALTITUDE RIDING

44 BRAKING

45 PARKING

45 ANTI-THEFT TIPS

MAINTENANCE

page

46 MAINTENANCE

- 46 THE IMPORTANCE OF
MAINTENANCE
- 47 MAINTENANCE SAFETY
- 48 SAFETY PRECAUTIONS
- 49 MAINTENANCE SCHEDULE
- 52 TOOL KIT
- 53 SERIAL NUMBERS
- 54 COLOUR LABEL
- 55 AIR CLEANER
- 57 ENGINE OIL
- 62 SPARK PLUG
- 64 IDLE SPEED
- 65 THROTTLE OPERATION
- 67 VALVE CLEARANCE
- 69 SPARK ARRESTER
- 70 DRIVE CHAIN
- 75 WHEEL RIMS AND SPOKES
- 76 WHEEL REMOVAL
- 79 BRAKE SHOE WEAR
- 80 FRONT SUSPENSION
- 81 REAR SUSPENSION
- 82 SIDE STAND

page

83 CLEANING

86 TRANSPORTING

88 STORAGE GUIDE

- 88 STORAGE
- 90 REMOVAL FROM STORAGE

91 TAKING CARE OF THE UNEXPECTED

92 SPECIFICATIONS

96 MANUFACTURER AND AUTHORISED REPRESENTATIVE FOR EU MARKET

MOTORCYCLE SAFETY

IMPORTANT MESSAGE TO PARENTS

Your child's safety is very important to Honda. That's why we urge you to read this message before you let any young person ride this motorcycle. Off-road riding can be fun. But as with riding a bicycle, bad judgements can result in injuries, and we don't want that to happen! As a parent, you can help prevent accidents by making good decisions about if, when, and how your youngster rides this motorcycle.

Riding Readiness

The first decision you'll need to make is whether your youngster is ready to ride. Riding readiness varies widely from one person to another, and age and size are not the only factors.

PHYSICAL ABILITY is an important consideration. For example, riders must be big enough to hold the motorcycle up, get on, and comfortably sit on the seat with both feet touching the ground. They should also be able to easily reach and work the brakes, the throttle and all other controls.

ATHLETIC ABILITY is necessary for riding a motorcycle. Generally speaking, your youngster should be good at riding a bicycle before getting on a motorcycle. Can your youngster judge speeds and distances on a bicycle and react with proper hand and foot actions? Anyone who does not have good coordination, balance, and agility is not ready to ride this motorcycle.

MENTAL AND EMOTIONAL MATURITY are requirements for safe riding. Does your youngster think through problems and come to logical solutions? On a bicycle, does your youngster obey safe riding rules? Be honest! Young people who take unnecessary risks, make bad judgements and don't obey rules are not ready to ride this motorcycle.

Instruction and Supervision

If you decide that your youngster is ready to safely operate this motorcycle, make sure both of you carefully read and understand the Owner's Manual before riding. Also be sure that your youngster has a helmet and other appropriate riding equipment and always wears it when operating the vehicle or sitting on it.

GOOD INSTRUCTION is an important part of hands-on training. The teacher can either be you or another responsible adult who has experience with off-road motorcycle riding. (For help in finding a qualified instructor, talk with your Honda dealer.) Even if you're not the main teacher, it's up to you to ensure your youngster's safety. Remember, learning to ride a motorcycle is a gradual step-by-step process. It takes time, patience and practice — many hours over a period of weeks or months.

SUPERVISION is another important obligation of parents. Even after youngsters have become skilled off-road riders, they should always ride with adult supervision. It helps to regularly remind young riders of basic safety rules and cautions. And remember, it's your responsibility to see that the vehicle is properly maintained and kept in safe operating condition.

SAFE AND RESPONSIBLE RIDING must be an ongoing commitment—by you and your youngster. When you both put safety first, you can enjoy more peace of mind, and your youngster can enjoy more hours of safe off-road riding.

For your convenience, this CRF70F comes with an ignition switch and key. Remove the key when the motorcycle is parked to help prevent unauthorized use.

IMPORTANT SAFETY INFORMATION

Your motorcycle can provide many years of service and pleasure—if you take responsibility for your own safety and understand the challenges you can meet while riding.

This motorcycle has been designed for younger riders, as well as for smaller adults. However, not all youngsters are physically or emotionally ready to ride. Therefore, before parents allow any youngster to ride this motorcycle, we urge them to carefully read the Important Message to Parents on page 1.

There is much that you can do to protect yourself when you ride. You'll find many helpful recommendations throughout this manual. Following are a few that we consider to be most important.

Always Wear a Helmet

It's a proven fact: helmets significantly reduce the number and severity of head injuries. So always wear an approved motorcycle helmet. We also recommend that you wear eye protection, sturdy boots, gloves and other protective gear (page 5).

Never Carry a Passenger

Your motorcycle is designed for one person only. There are no handholds, footrests, or seat for a second person—so never carry a passenger. A passenger could interfere with your ability to move around to maintain your balance and control of the motorcycle.

Ride Off-Road Only

Your motorcycle is designed and manufactured for off-road use only. The tyres are not made for pavement, and the motorcycle does not have turn signals and other features required for use on public roads. If you need to cross a paved or public road, get off and walk your motorcycle across.

Take Time to Learn and Practice

Developing off-road riding skills is a gradual, step-by-step process. Start by practicing at low speeds in a safe area and slowly build your skills. Personal instruction from an experienced rider can also be valuable.

If you need assistance, ask your dealer about riding groups in your area.

Be Alert for Off-Road Hazards

The terrain can present a variety of challenges when you ride off-road. Continually “read” the terrain for unexpected turns, drop-offs, rocks, ruts, and other hazards. Always keep your speed low enough to allow time to see and react to hazards.

Ride Within Your Limits

Pushing the limits is another major cause of motorcycle accidents. Never ride beyond your personal abilities or faster than conditions warrant. Remember that alcohol, drugs, fatigue and inattention can significantly reduce your ability to make good judgements and ride safely.

Don't Drink and Ride

Alcohol and riding don't mix. Even one drink can reduce your ability to respond to changing conditions, and your reaction time gets worse with every additional drink. So don't drink and ride, and don't let your friends drink and ride either.

Keep Your Bike in Safe Condition

For safe riding, it's important to inspect your motorcycle before every ride and perform all recommended maintenance. Never exceed load limits, and only use accessories that have been approved by Honda for this motorcycle. See page 7 for more details.

Others

- This motorcycle is not equipped with lights. Don't ride at night.

PROTECTIVE APPAREL

For your safety, we strongly recommend that you always wear an approved motorcycle helmet, eye protection, boots, gloves, long pants, and a long-sleeved jersey, shirt or jacket whenever you ride. Although complete protection is not possible, wearing proper gear can reduce the chance of injury when you ride.

Following are suggestions to help you choose proper gear.

⚠ WARNING

Not wearing a helmet increases the chance of serious injury or death in a crash.

Be sure you always wear a helmet, eye protection and other protective apparel when you ride.

Helmets and Eye Protection

Your helmet is your most important piece of riding gear because it offers the best protection against head injuries. A helmet should fit your head comfortably and have a chin strap that can be tightened securely.

An open-face helmet offers some protection, but a full-face helmet offers more. Always wear a face shield or goggles to protect your eyes and help your vision.

Additional Riding Gear

In addition to a helmet and eye protection, we also recommend:

- Sturdy off-road motorcycle boots to help protect your feet, ankles, and lower legs.
- Off-road motorcycle gloves to help protect your hands.
- Riding pants with knee and hip pads, a riding jersey with padded elbows, and a chest/shoulder protector.

LOAD LIMITS AND GUIDELINES

Your Honda was designed as a rider-only motorcycle. It was not designed to carry a passenger or cargo. A passenger or cargo could interfere with your ability to move around to maintain your balance and control of the motorcycle.

In addition, exceeding the weight limits or carrying an unbalanced load can seriously affect your motorcycle's handling, braking, and stability. Adding accessories or making modifications that change this motorcycle's design and performance can also make it unsafe. Also, the weight of any accessories will reduce the maximum load the motorcycle can carry.

The following pages give more specific information on loading, accessories and modifications.

Loading

How much weight you put on your motorcycle, and how you load it, are important to your safety. If you decide to carry cargo, you should be aware of the following information.

WARNING

Overloading or carrying a passenger can cause a crash and you can be seriously hurt or killed.

Follow all load limits and other loading guidelines in this manual.

Load Limits

Following are the load limits for your motorcycle:

Maximum weight capacity:

60 kg (132 lbs)

Includes the weight of the rider and any accessories

Loading Guidelines

As discussed on page 7, we recommend that you do not carry any cargo on this motorcycle. However, if you decide to carry cargo, ride at reduced speeds and follow these common-sense guidelines:

- Keep cargo small and light. Make sure it cannot easily be caught on brush or other objects, and that it does not interfere with your ability to shift position to maintain balance and stability.

- Place weight as close to the center of the motorcycle as possible.
- Do not attach large or heavy items (such as a sleeping bag or tent) to the handlebar, fork, or front fender.
- Make sure that all cargo is tied down securely.
- Never exceed the maximum weight limit.
- Check that both tyres are properly inflated (page 26).

Accessories and Modifications

Modifying your motorcycle or using non-Honda accessories can make your motorcycle unsafe. Before you consider making any modifications or adding an accessory, be sure to read the following information.

WARNING

Improper accessories or modifications can cause a crash in which you can be seriously hurt or killed.

Follow all instructions in this owner's manual regarding accessories and modifications.

Accessories

We strongly recommend that you use only Honda Genuine Accessories that have been specifically designed and tested for your motorcycle. Because Honda cannot test all other accessories, you must be personally responsible for proper selection, installation and use of non-Honda accessories. Check with your dealer for assistance and always follow these guidelines:

- Make sure the accessory does not reduce ground clearance and lean angle, limit suspension travel or steering travel, alter your riding position or interfere with operating any controls.

Modifications

We strongly advise you not to remove any original equipment or modify your motorcycle in any way that would change its design or operation. Such changes could seriously impair your motorcycle's handling, stability and braking, making it unsafe to ride.

Removing or modifying your exhaust system (such as the spark arresters or mufflers) or other equipment can also make your motorcycle illegal.

SAFETY LABELS

This page shows the locations of safety labels on your motorcycle. Some labels warn you of potential hazards that could cause serious injury. Others provide important safety information. Read these labels carefully and don't remove them.

If a label comes off or becomes hard to read, contact your Honda dealer for a replacement.

(For ED type)

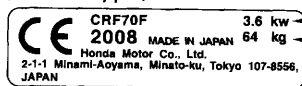

Engine net power

Machine mass

TIRE INFORMATION	
Cold tire pressures :	Front 100kPa 1.00kg/cm ² 15psi
	Rear 100kPa 1.00kg/cm ² 15psi
Maximum weight capacity :	60kg(132lb)
Tire size :	Front 2.50-14 4PR
	Rear 3.00-12 4PR

For your protection, always wear your helmet while riding.
Operator only. No passengers.
Read the owner's manual carefully.

OFF ROAD USE ONLY

THIS VEHICLE IS DESIGNED AND MANUFACTURED FOR OFF ROAD USE ONLY. IT DOES NOT CONFORM TO FEDERAL MOTOR VEHICLE SAFETY STANDARDS AND OPERATION ON PUBLIC STREETS, ROADS, OR HIGHWAYS IS ILLEGAL.

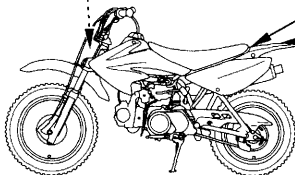

PARTS LOCATION

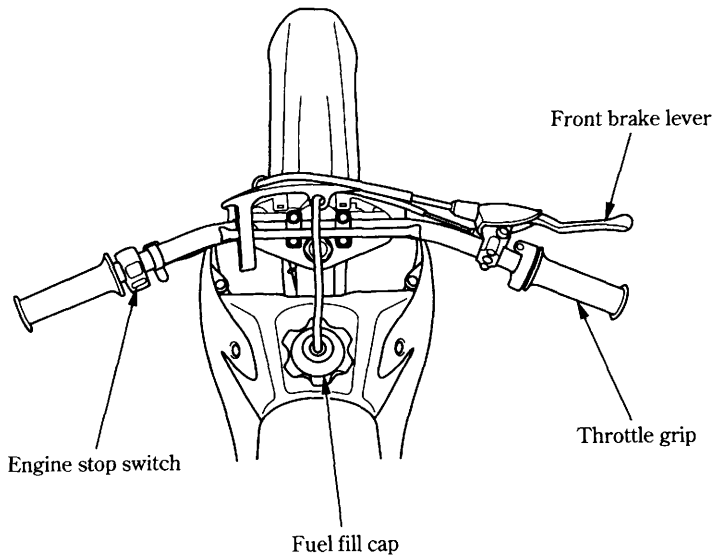

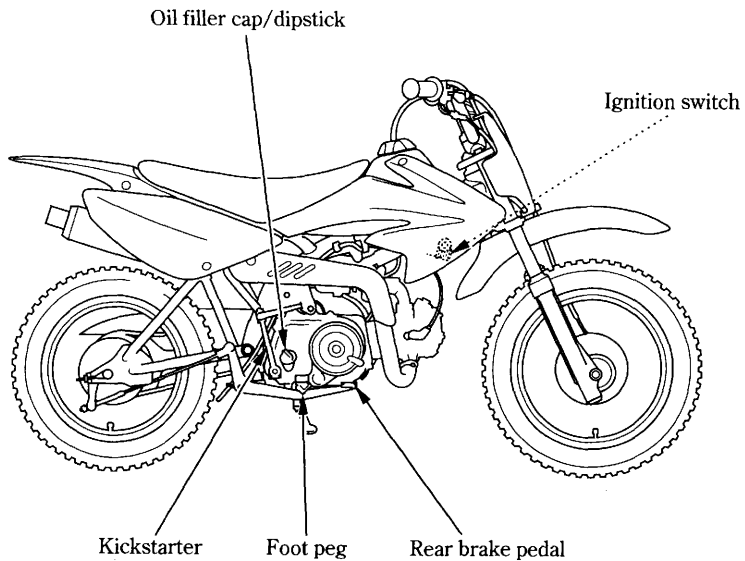

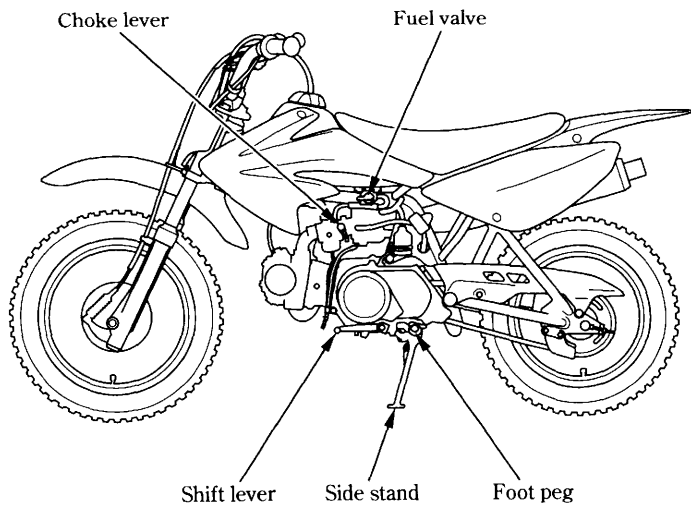

MAJOR COMPONENTS

(Information you need to operate this motorcycle)

BRAKES

Front Brake

Brakes are items of personal safety and should always be maintained in proper adjustment.

The distance the front brake lever or rear brake pedal moves before the brake starts to engage is called freeplay.

Measured at the tip of the front brake lever (1), freeplay should be maintained at:

20–30 mm (0.8–1.2 in)

Adjust the freeplay of the brake lever with the front wheel pointed straight ahead.

Adjustment:

1. Pull back the rubber dust cover (2). Loosen the lock nut (3) and turn the adjuster (4). Tighten the lock nut (3) and check the adjustment.

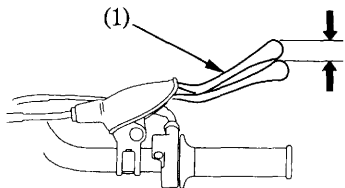

(1) Front brake lever

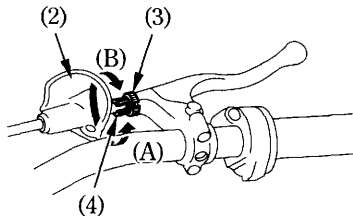

- | | |
|--------------------------------|-----------------------|
| (2) Dust cover | (A) Decrease freeplay |
| (3) Lock nut | (B) Increase freeplay |
| (4) Front brake cable adjuster | |

2. If the adjuster is threaded out near its limit or the correct freeplay cannot be obtained using the cable adjuster (4), loosen the lock nut (3) and turn in the cable adjuster (4) completely. Tighten the lock nut (3) and install the rubber dust cover.
3. Loosen the front brake cable guide bolt (5).

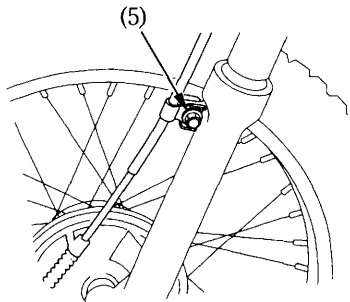

(5) Cable guide bolt

4. Loosen the lock nut (6) at the lower end of the cable. Turn the adjusting nut (7) to obtain the specified freeplay. Tighten the lock nut and check the adjustment.

If proper adjustment cannot be obtained by this method, see your Honda dealer.

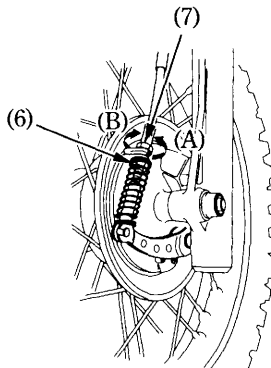

(6) Lock nut

(7) Adjusting nut

(A) Decrease freeplay

(B) Increase freeplay

5. Apply the brake several times and check for free wheel rotation after the brake lever is released.

Tighten the front brake cable guide bolt.

After adjustment, push the brake arm (8) to confirm that there is proper freeplay.

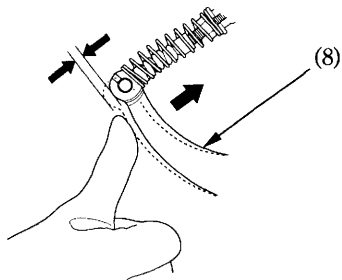

(8) Brake arm

After adjustment, confirm the freeplay of the brake lever.

Other Checks:

Check the brake cable for kinks or signs of wear that could cause sticking or failure.

Lubricate the brake cable with a commercially available cable lubricant to prevent premature wear and corrosion.

Make sure the brake arm, spring and fasteners are in good condition.

Rear Brake

Brake Adjustment:

1. Place the motorcycle on its side stand.
2. Measure the distance the rear brake pedal (1) moves before the brake starts to take hold.

Freeplay should be:

20–30 mm (0.8–1.2 in)

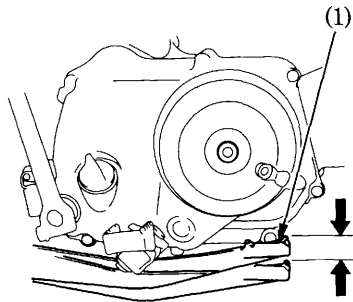

(1) Rear brake pedal

3. If adjustment is necessary, turn the rear brake adjusting nut (2).

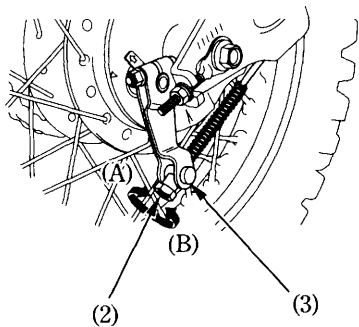

- (2) Rear brake adjusting nut
(3) Brake arm pin
(A) Decrease freeplay
(B) Increase freeplay

Adjust by turning the rear brake adjusting nut a half-turn at a time. Make sure the cut-out on the adjusting nut is seated on the brake arm pin (3) after making final freeplay adjustment.

4. Apply the brake several times and check for free wheel rotation after the brake pedal is released.

If proper adjustment cannot be obtained by this method, see your Honda dealer.

After adjustment, push the brake arm (4) to confirm that there is a gap between the adjusting nut (2) and the brake arm pin (3).

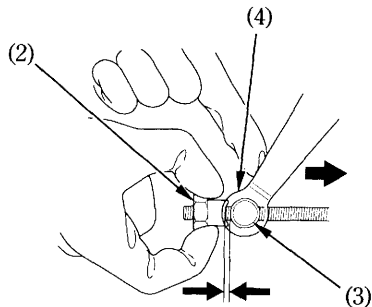

- (2) Adjusting nut
(3) Brake arm pin

(4) Brake arm

After adjustment, confirm the freeplay of the brake pedal.

Other Checks:

Make sure the brake rod, brake arm, spring and fasteners are in good condition.

CLUTCH

Adjustment:

1. Loosen the adjuster lock nut (1).
2. Turn the clutch adjuster (2) clockwise one turn; do not turn excessively.
3. Slowly turn the adjuster counterclockwise until a slight resistance is felt.
4. From this position, turn the adjuster clockwise $1/8$ to $1/4$ turn, and tighten the lock nut.
5. After adjustment, test ride the motorcycle to be certain the clutch operates properly.

The engine should start easily with the kickstarter without the clutch slipping. When shifting gears, the clutch operation should be smooth and light, especially when shifting into neutral.

If proper adjustment cannot be obtained or the clutch does not work correctly, see your Honda dealer.

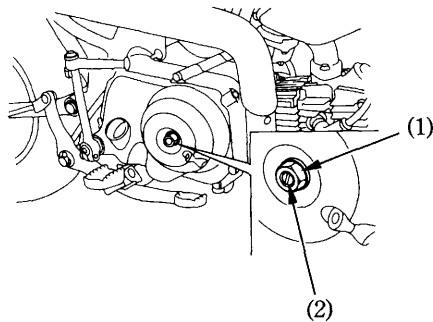

(1) Lock nut

(2) Clutch adjuster

FUEL

Fuel Valve

The three way fuel valve (1) is on the left side near the carburetor.

OFF

With the fuel valve in the OFF position, fuel cannot flow from the tank to the carburetor. Turn the valve OFF whenever the motorcycle is not in use.

ON

With the fuel valve in the ON position, fuel will flow from the main fuel supply to the carburetor.

RES

With the fuel valve in the RES position, fuel will flow from the reserve fuel supply to the carburetor. Use the reserve fuel only when the main supply is gone. Refill the tank as soon as possible after switching to RES.

The reserve fuel supply is:

0.7 l (0.18 US gal , 0.15 Imp gal)

Remember to check that the fuel valve is in the ON position each time you refuel. If the valve is left in the RES position, you may run out of fuel with no reserve.

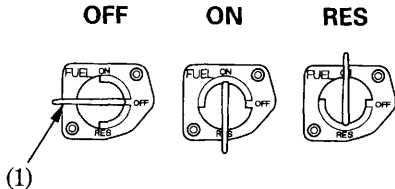

(1) Fuel valve

Fuel Tank

The fuel tank capacity including the reserve supply is:

5.0 l (1.32 US gal, 1.10 Imp gal)

To open the fuel fill cap (1), pull the breather tube (2) from the front number plate (3). Turn the fuel fill cap counterclockwise.

Do not overfill the tank. There should be no fuel in the filler neck (4).

After refueling, be sure to tighten the fuel fill cap firmly by turning it clockwise. Insert the breather tube into the front number plate.

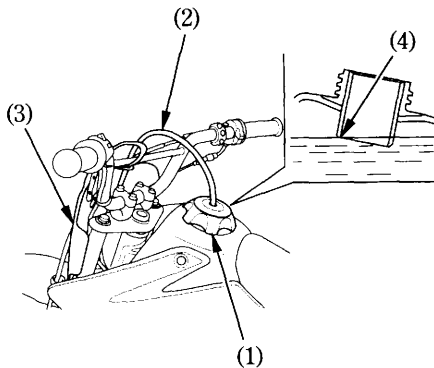

⚠ WARNING

Petrol is highly flammable and explosive. You can be burned or seriously injured when handling fuel.

- Stop the engine and keep heat, sparks, and flame away.
- Refuel only outdoors.
- Wipe up spills immediately.

- (1) Fuel fill cap (3) Front number plate
(2) Breather tube (4) Filler neck

Use unleaded or low-lead petrol with a research octane number of 91 or higher. We recommend that you use unleaded petrol because it produces fewer engine and spark plug deposits and extends the life of exhaust system components.

NOTICE

If “spark knock” or “pinking” occurs at a steady engine speed under normal load, change brands of petrol. If spark knock or pinking persists, consult your Honda dealer. Failure to do so is considered misuse, and damage caused by misuse is not covered by Honda’s Limited Warranty.

Occasionally you may experience light spark knock while operating under heavy loads. This is no cause for concern, it simply means your engine is operating efficiently.

Petrol Containing Alcohol

If you decide to use a petrol containing alcohol (gasohol), be sure it's octane rating is at least as high as that recommended by Honda. There are two types of "gasohol": one containing ethanol, and the other containing methanol. Do not use petrol that contains more than 10 % ethanol. Do not use petrol containing methanol (methyl or wood alcohol) that does not also contain cosolvents and corrosion inhibitors for methanol. Never use petrol containing more than 5 % methanol, even if it has cosolvents and corrosion inhibitors.

Fuel system damage or engine performance problems resulting from the use of fuels that contain alcohol is not covered under the warranty. Honda cannot endorse the use of fuels containing methanol since evidence of their suitability is as yet incomplete.

Before buying fuel from an unfamiliar station, try to find out if the fuel contains alcohol. If it does, confirm the type and percentage of alcohol used. If you notice any undesirable operating symptoms while using a petrol that contains alcohol, or one that you think contains alcohol, switch to a petrol that you know does not contain alcohol.

ENGINE OIL

Engine Oil Level Check

Check the engine oil level each day before operating the motorcycle.

The oil filler cap/dipstick (1) is at the rear of the right crankcase cover and contains a dipstick for measuring the oil level. Oil level must be maintained between the upper (2) and lower (3) level marks on the oil filler cap/dipstick.

1. Hold the motorcycle upright on firm level ground.
2. Start the engine and let it idle for 3–5 minutes.
3. Stop the engine. After 2–3 minutes, remove the oil filler cap/dipstick, wipe it clean, and reinsert the oil filler cap/dipstick without screwing it in. Remove the oil filler cap/dipstick. The oil level should be between the upper and lower level marks on the oil filler cap/dipstick.
4. If required, add the specified oil (see page 57) up to the upper level mark. Do not overfill.

5. Reinstall the oil filler cap/dipstick. Check for oil leaks.

NOTICE

Running the engine with insufficient oil can cause serious engine damage.

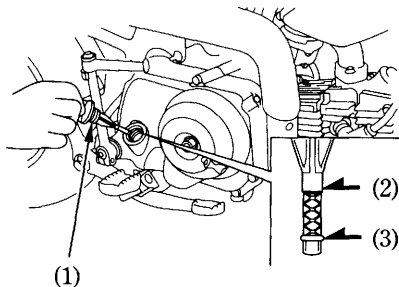

- (1) Oil filler cap/dipstick
- (2) Upper level mark
- (3) Lower level mark

TYRES

To safely operate your motorcycle, the tyres must be the proper type (off-road) and size, in good condition with adequate tread, and correctly inflated.

WARNING

Using tyres that are excessively worn or improperly inflated can cause a crash in which you can be seriously hurt or killed.

Follow all instructions in this owner's manual regarding tyre inflation and maintenance.

Air Pressure

Properly inflated tyres provide the best combination of handling, tread life, and riding comfort. Generally, underinflated tyres wear unevenly, adversely affect handling, and are more likely to fail from being overheated. Underinflated tyres can also cause wheel damage in rocky terrain. Overinflated tyres make your motorcycle ride harshly, are more prone to damage from surface hazards, and wear unevenly.

Make sure the valve stem caps are secure. If necessary, install new caps.

Always check air pressure when your tyres are “cold.” If you check air pressure when your tyres are “warm”—even if your motorcycle has only been ridden for a few miles—the readings will be higher. If you let air out of warm tyres to match the recommended cold pressures, the tyres will be underinflated.

The recommended “cold” tyre pressures are:

Front	100 kPa (1.00 kgf/cm ² , 15 psi)
Rear	100 kPa (1.00 kgf/cm ² , 15 psi)

Inspection

Whenever you check the tyre pressures, you should also examine the tyre treads and sidewalls for wear, damage, and foreign objects:

Look for:

- Bumps or bulges in the side of the tyre or the tread. Replace the tyre if you find any bumps or bulges.
- Cuts, splits or cracks in the tyre. Replace the tyre if you can see fabric or cord.
- Excessive tread wear.

Also, if you hit a pothole or hard object, pull to the side of the road as soon as you can safely and carefully inspect the tyres for damage.

Tread Wear

Replace tyres before tread depth at the center of the tyre reaches the following limit:

Minimum tread depth	
Front:	3.0 mm (0.12 in)
Rear:	3.0 mm (0.12 in)

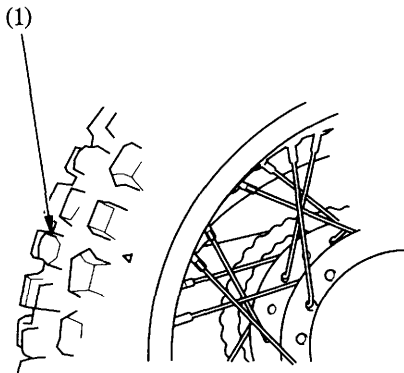

(1) Tyre tread depth

Tube Repair and Replacement

If a tube is punctured or damaged, you should replace it as soon as possible. A tube that is repaired may not have the same reliability as a new one, and it may fail while you are riding.

If you need to make a temporary repair by patching a tube or using an aerosol sealant, ride cautiously at reduced speed and have the tube replaced before you ride again. Any time a tube is replaced, the tyre should be carefully inspected as described on page 27 .

Tyre Replacement

The tyres that came on your motorcycle were designed to match the performance capabilities of your motorcycle and provide the best combination of handling, braking, durability and comfort.

⚠ WARNING

Installing improper tyres on your motorcycle can affect handling and stability. This can cause a crash in which you can be seriously hurt or killed.

Always use the size and type of tyres recommended in this owner's manual.

The recommended tyres for your motorcycle are:

Front: 2.50-14 4PR

Rear: 3.00-12 4PR

Type: bias-ply, tube

Whenever you replace a tyre, use one that is equivalent to the original and be sure the wheel is balanced after the new tyre is installed.

Also remember to replace the inner tube whenever you replace a tyre. The old tube will probably be stretched, and if installed in a new tyre, it could fail.

ESSENTIAL INDIVIDUAL COMPONENTS

IGNITION SWITCH

The ignition switch (1) is located below the fuel tank.

The ignition switch is used to prevent unauthorized use of the motorcycle.

Before riding, insert the key and turn it to the ON position.

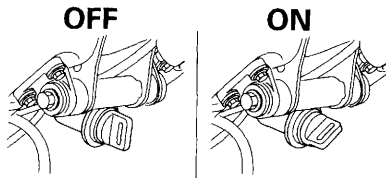
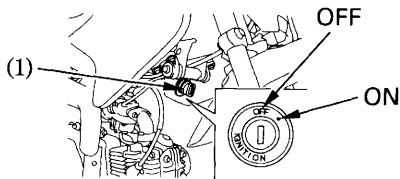

After parking the motorcycle, remove the key.



(1) Ignition switch

Key Position	Function	Key Removal
OFF	The engine cannot be operated.	Key can be removed
• (ON)	With the engine stop switch at \odot (RUN) and the transmission in neutral, the engine can be started.	Key cannot be removed

ENGINE STOP SWITCH

The engine stop switch (1) is next to the left handlebar grip. When the switch is in the  (RUN) position, the engine will operate. When the switch is in the  (OFF) position, the engine will not operate. This switch is intended primarily as a safety or emergency switch and should normally remain in the  (RUN) position.

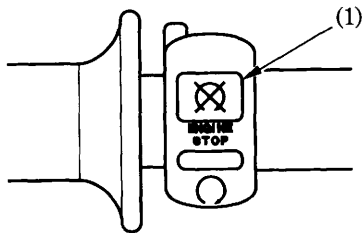

(1) Engine stop switch

FEATURES (Not required for operation)

SEAT

Removal:

1. Remove the bolts A (1) on each side of the rear fender.
2. Remove the bolts B (2) under the rear fender.
3. Pull both side cover prongs (3) out of the rubber grommets (4).
4. Slide the seat and rear fender back.

Installation:

1. Align the locating slot (5) under the front of the seat with the pin (6) on the rear of the fuel tank.
2. Align the locating prongs (7) on the bottom of the seat with the hooks (8) on the frame.
3. Slide the seat into position.
4. Align the side cover prongs with the rubber grommets. Press the side cover into position.
5. Install the bolts and tighten them.

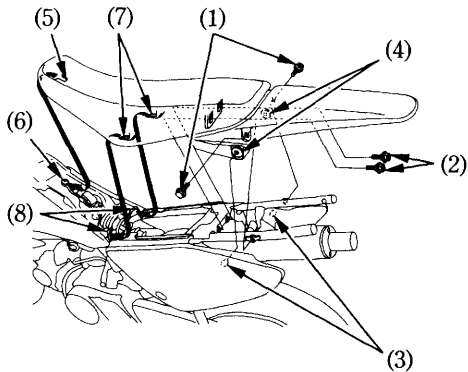

- | | |
|-----------------------|-----------------|
| (1) Bolts A | (5) Slot |
| (2) Bolts B | (6) Pin |
| (3) Side cover prongs | (7) Seat prongs |
| (4) Rubber grommets | (8) Hooks |

SIDE COVER

Removal:

1. Remove the bolt (1) securing the side cover.
2. Pull the side cover prong (2) out of the rubber grommet (3).

Installation:

1. Attach the side cover on the rear frame.
2. Align the side cover prong with the rubber grommet. Press the side cover into position.
3. Install the securing bolt and tighten it.

Use the same procedure to remove and install the left side cover.

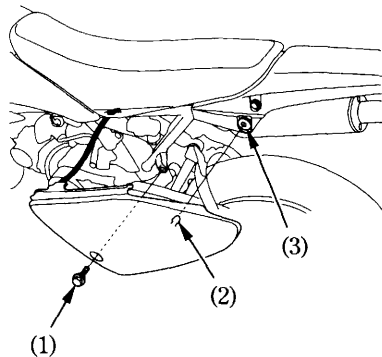

- (1) Bolt
- (2) Prong
- (3) Grommet

OPERATION

PRE-RIDE INSPECTION

For your safety, it is very important to take a few moments before each ride to walk around your motorcycle and check its condition. If you detect any problem, be sure you take care of it, or have it corrected by your Honda dealer.

WARNING

Improperly maintaining this motorcycle or failing to correct a problem before riding can cause a crash in which you can be seriously hurt or killed.

Always perform a pre-ride inspection before every ride and correct any problems.

1. Engine oil level—add engine oil if required (page 57). Check for leaks.
2. Fuel level—fill fuel tank when necessary (page 22). Check for leaks.
3. Front and rear brakes—check operation and if necessary, adjust freeplay (pages 15 – 19).
4. Tyres—check condition and pressure (pages 26 – 30).
5. Spokes—check and tighten if necessary (page 75).
6. Drive chain—check condition and slack (page 70). Adjust and lubricate if necessary.
7. Chain slider—check slider wear (page 71).
8. Throttle—check for smooth opening and full closing in all steering positions. Adjust freeplay if necessary (pages 65 – 66).

9. Spark plug and high tension terminal – check for looseness.
10. Engine stop switch—check for proper function (page 32).
11. Nuts, bolts, fasteners – check the front and rear wheels to see that the axle nuts are tightened securely. Check security of all other nuts, bolts, and fasteners.

STARTING THE ENGINE

Always follow the proper starting procedure described below.

Your motorcycle's exhaust contains poisonous carbon monoxide gas. High levels of carbon monoxide can collect rapidly in enclosed areas such as a garage. Do not run the engine with the garage door closed. Even with the door open, run the engine only long enough to move your motorcycle out of the garage.

Preparation

Before starting, insert the key and turn the ignition switch ON.

Make sure that the transmission is in neutral. Turn the engine stop switch to

○ (RUN) and the fuel valve ON.

Starting Procedure

To restart a warm engine, follow the procedure for "High Air Temperature."

Normal Air Temperature

10° - 35°C (50° - 95°F)

1. Pull the choke lever (1) up all the way to Fully ON (A).

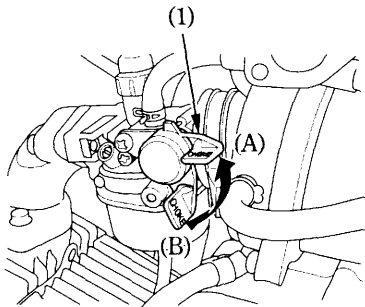

(1) Choke lever

(A) Fully ON

(B) Fully OFF

2. With the throttle slightly open, operate the kickstarter. Kick from the top of the stroke through to the bottom with a rapid, continuous motion.

NOTICE

Allowing the kickstarter to snap back freely against the pedal stop can damage the engine case.

3. Warm up the engine by opening and closing the throttle slightly.
4. About a quarter minute after the engine starts, push the choke lever (1) down all the way to Fully OFF (B).
5. If idling is unstable, open the throttle slightly.

High Air Temperature

35°C (95°F) or above

1. Do not use the choke.
2. Start the engine following step 2 under “Normal Air Temperature.”

Low Air Temperature



10°C (50°F) or below

1. Follow steps 1–2 under “Normal Air Temperature”.
2. Warm up the engine by opening and closing the throttle slightly.
3. Continue warming up the engine until it runs smoothly and responds to the throttle, when the choke lever (1) is at Fully OFF (B).

NOTICE

Extended use of the choke may impair piston and cylinder wall lubrication and damage the engine.

Flooded Engine

If the engine fails to start after repeated attempts, it may be flooded with excess fuel. To clear a flooded engine, turn the engine stop switch to  (OFF) and push the choke lever down to Fully OFF (B). Open the throttle fully and crank the engine several times with the kickstarter. Turn the engine stop switch to  (RUN) and open the throttle slightly; start the engine using the kickstarter.

RUNNING-IN

Help assure your motorcycle's future reliability and performance by paying extra attention to how you ride during the first operating day or 25 km (15 miles).

During this period, avoid full-throttle starts and rapid acceleration.

RIDING

Review Motorcycle Safety (pages 1 – 10) before you ride.

Make sure the side stand is fully retracted before riding the motorcycle. If the stand is extended, it may interfere with control during a left turn.

Make sure you understand the function of the side stand mechanism. (See MAINTENANCE SCHEDULE on page 49 and explanation for SIDE STAND on page 82).

1. After the engine has warmed up, the motorcycle is ready for riding.
2. Close the throttle and raise the shift lever to shift into 1st (low) gear.

3. Increase engine speed by gradually opening the throttle.
4. When your speed increases, close the throttle and shift to 2nd gear by raising the shift lever.
5. This sequence is repeated to shift to 3rd gear.

6. Raise the pedal to shift to a higher gear and depress the pedal to shift to a lower gear. Each stroke of the pedal engages the next gear in sequence. The pedal automatically returns to the horizontal position when released.

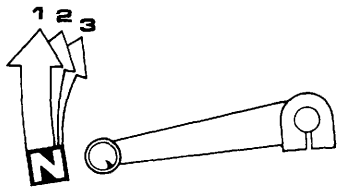

Shifting pattern

- Do not downshift when traveling at a speed that would force the engine to overrev in the next lower gear; the rear wheel may lose traction, resulting in a possible loss of vehicle control.
- Do not shift gears without closing the throttle. The engine and drive train could be damaged by overspeed and shock.
- Do not tow the motorcycle or coast for long distances while the engine is off. The transmission will not be properly lubricated and damage may result.
- Do not run the engine at high rpm with the transmission in neutral. Serious engine damage may result.

HIGH ALTITUDE RIDING

When operating this motorcycle at high altitude the air-fuel mixture becomes overly rich. Driveability and performance may be reduced and fuel consumption increased. The carburetor can be modified to compensate for this high altitude richness, however it must be returned to standard specifications before extended operation at low altitudes (below 1,200 m, 4,000 feet). See your Honda dealer for this high altitude modification.

NOTICE

Sustained operation at lower altitudes with high altitude carburetor modifications may cause engine overheating and damage.

BRAKING

For normal braking, gradually apply both the front and rear brakes while downshifting to suit your road speed.

For maximum deceleration, close the throttle and apply the front and rear brakes firmly.

Important Safety Reminders:

- Independent operation of only the brake lever or brake pedal reduces stopping performance.
- Extreme application of the brake controls may cause wheel lock, reducing control of the motorcycle.
- When possible, reduce speed or brake before entering a turn; closing the throttle or braking in mid-turn may cause wheel slip. Wheel slip will reduce control of the motorcycle.

- When riding in wet or rainy conditions, or on loose surfaces, the ability to maneuver and stop will be reduced. All of your actions should be smooth under these conditions. Rapid acceleration, braking or turning may cause loss of control. For your safety, exercise extreme caution when braking, accelerating or turning.
- When descending a long, steep grade, use engine compression braking by downshifting, with intermittent use of both brakes. Continuous brake application can overheat the brakes and reduce their effectiveness.

PARKING

1. After stopping the motorcycle, shift the transmission into neutral and turn the fuel valve OFF. Turn the engine stop switch  (OFF).
2. Use the side stand to support the motorcycle while parked.

Park the motorcycle on firm, level ground to prevent it from falling over.

If you must park on a slight incline, aim the front of the motorcycle uphill to reduce the possibility of rolling off the side stand or overturning.

3. Turn the ignition switch OFF and remove the key.

ANTI-THEFT TIPS

1. Be sure the registration information for your motorcycle is accurate and current.
2. Park your motorcycle in a locked garage whenever possible.
3. Use an additional anti-theft device of good quality.
4. Put your name, address and phone number in this Owner's Manual and keep it on your motorcycle at all times. Many times stolen motorcycles are identified by information in the Owner's Manuals which are still with them.

NAME: _____

ADDRESS: _____

PHONE NO: _____

MAINTENANCE

THE IMPORTANCE OF MAINTENANCE

A well-maintained motorcycle is essential for safe, economical, and trouble-free riding. It will also help reduce air pollution. Careful pre-ride inspections and good maintenance are especially important because your motorcycle is designed to be ridden over rough off-road terrain.

To help you properly care for your motorcycle, this section of the manual provides a Maintenance Schedule.

The service intervals in this schedule are based on average riding conditions.

More frequent service is needed if you subject your motorcycle to severe use (such as competition) or ride in unusually wet or dusty areas.

Frequent servicing of the air cleaner is especially important to help you avoid a possible costly engine repair.

If your motorcycle overturns or becomes involved in a crash, be sure your Honda dealer inspects all major parts, even if you are able to make some repairs.

WARNING

Improperly maintaining this motorcycle or failing to correct a problem before you ride can cause a crash in which you can be seriously hurt or killed.

Always follow the inspection and maintenance recommendations and schedules in this owner's manual.

MAINTENANCE SAFETY

This section includes instructions on some important maintenance tasks. You can perform some of these tasks with the tools provided — if you have basic mechanical skills.

Other tasks that are more difficult and require special tools are best performed by professionals. Wheel removal should normally be handled only by a Honda technician or other qualified mechanic; instructions are included in this manual only to assist in emergency service.

Some of the most important safety precautions follow. However, we cannot warn you of every conceivable hazard that can arise in performing maintenance. Only you can decide whether or not you should perform a given task.

⚠ WARNING

Failure to properly follow maintenance instructions and precautions can cause you to be seriously hurt or killed.

Always follow the procedures and precautions in this owner's manual.

SAFETY PRECAUTIONS

- Make sure the engine is off before you begin any maintenance or repairs. This will help eliminate several potential hazards:
 - * **Carbon monoxide poisoning from engine exhaust.**
Be sure there is adequate ventilation whenever you operate the engine.
 - * **Burns from hot parts.**
Let the engine and exhaust system cool before touching.
 - * **Injury from moving parts.**
Do not run the engine unless instructed to do so.
- Read the instructions before you begin, and make sure you have the tools and skills required.
- To help prevent the motorcycle from falling over, park it on a firm, level surface, using the side stand or a maintenance stand to provide support.

- To reduce the possibility of a fire or explosion, be careful when working around petrol. Use only nonflammable solvent, not petrol, to clean parts. Keep cigarettes, sparks and flames away from all fuel-related parts.

Remember that your Honda dealer knows your motorcycle best and is fully equipped to maintain and repair it.

To ensure the best quality and reliability, use only new Honda Genuine Parts or their equivalents for repair and replacement.

MAINTENANCE SCHEDULE

Perform the Pre-ride Inspection (page 35) at each scheduled maintenance period.

I: INSPECT AND CLEAN, ADJUST, LUBRICATE OR REPLACE IF NECESSARY

C: CLEAN R: REPLACE A: ADJUST L: LUBRICATE

The following Maintenance Schedule specifies all maintenance required to keep your motorcycle in peak operating condition. Maintenance work should be performed in accordance with standards and specifications of Honda by properly trained and equipped technicians. Your Honda dealer meets all of these requirements.

- * Should be serviced by your Honda dealer, unless the owner has proper tools and service data and is mechanically qualified. Refer to the Official Honda Shop Manual.
- ** In the interest of safety, we recommend these items be serviced only by your Honda dealer.

Honda recommends that your Honda dealer should road test your motorcycle after each periodic maintenance is carried out.

NOTE: (1) Service more frequently when ridden in wet or dusty conditions.

ITEMS	FREQUENCY	WHICHEVER → COMES FIRST ↓ NOTE	INITIAL MAINT.		REGULER MAINT. INTERVAL					
			km	150	1,000	2,000	3,000	4,000	REFER TO PAGE	
			mi	100	600	1,200	1,800	2,400		
			MONTH	1	6	12	18	24		
*	FUEL LINE				I		I	—		
*	THROTTLE OPERATION				I		I	65		
	AIR CLEANER	NOTE (1)		C	C	C	C	55		
	SPARK PLUG			I	I	I	I	62		
*	VALVE CLEARANCE		I	I	I	I	I	67		
	ENGINE OIL		R	R	R	R	R	57		
**	ENGINE OIL STRAINER SCREEN				C		C	—		
**	ENGINE OIL CENTRIFUGAL FILTER				C		C	—		
**	ENGINE IDLE SPEED		I	I	I	I	I	64		

ITEMS	FREQUENCY	WHICHEVER → COMES FIRST ↓ NOTE	INITIAL MAINT.		REGULER MAINT. INTERVAL					REFER TO PAGE	
			km	150	1,000	2,000	3,000	4,000			
			mi	100	600	1,200	1,800	2,400			
MONTH	1	6	12	18	24						
DRIVE CHAIN		NOTE (1)		I, L	Every 500 km (300 mi) or every 3 months: I,L					70	
DRIVE CHAIN SLIDER					I	I	I	I		71	
BRAKE SHOE WEAR					I	I	I	I		79	
BRAKE SYSTEM				I	I	I	I	I		15, 18, 79	
CLUTCH SYSTEM				I	I	I	I	I		20	
SIDE STAND						I		I		82	
* SUSPENSION						I		I		80, 81	
* SPARK ARRESTER						Every 1,600 km (1,000 mi) or every 100 operating hours: C					69
* NUTS, BOLTS, FASTENERS				I		I		I		—	
** WHEELS/TYRES				I	I	I	I	I		26, 75	
** STEERING HEAD BEARINGS				I		I		I		—	

TOOL KIT

The spark plug wrench (1) and its handle (2) are stored in the tool bag (3).

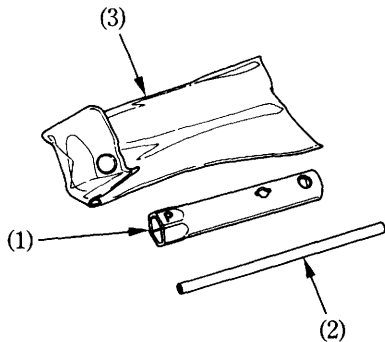

- (1) Spark plug wrench
- (2) Handle
- (3) Tool bag

SERIAL NUMBERS

The frame and engine serial numbers are required when registering your motorcycle. They may also be required by your dealer when ordering replacement parts.

Record the numbers here for your reference.

FRAME NO. _____

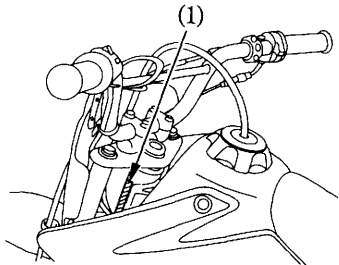

(1) Frame number

The frame number (1) is stamped on the left side of the steering head.

The engine number (2) is stamped on the left side of the engine.

ENGINE NO. _____

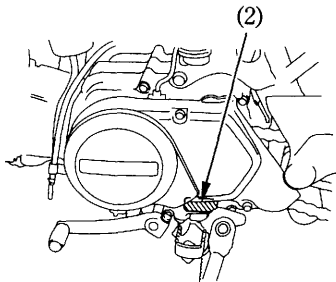

(2) Engine number

COLOUR LABEL

The colour label (1) is attached to the frame behind the left side cover (page 34). It is helpful when ordering replacement parts. Record the colour and code here for your reference.

COLOUR _____

CODE _____

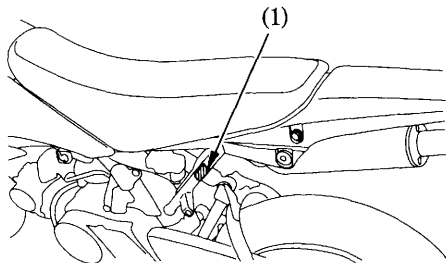

(1) Colour label

AIR CLEANER

Refer to the Safety Precautions on page 48 .

The air cleaner element should be serviced at regular intervals (page 50). If your motorcycle is operated in dusty areas, more frequent servicing will be required. Your Honda dealer can help you to determine the correct service interval for your particular riding conditions.

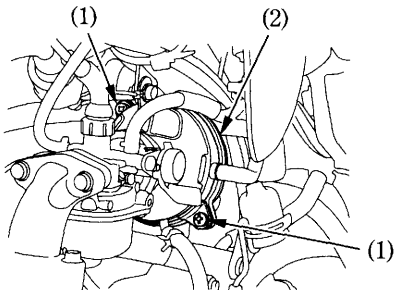

- (1) Attaching screws
- (2) Air cleaner housing cover

1. Remove the two attaching screws (1), the air cleaner housing cover (2) and air cleaner (3).
2. Wash the air cleaner in clean, nonflammable or high flash point solvent and let it dry thoroughly.

Never use petrol or low flash point solvents for cleaning the air cleaner. A fire or explosion could result.

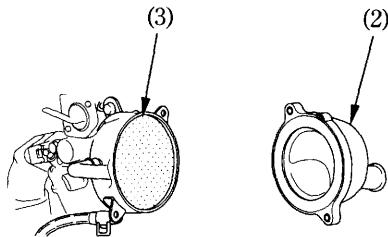

- (3) Air cleaner

3. Soak the air cleaner in gear oil (SAE 80–90) until saturated, then squeeze out the excess oil.
4. Reinstall the air cleaner.
5. Reinstall the air cleaner housing cover (2), aligning its projection (4) with the projection (5) on the air cleaner housing (6).

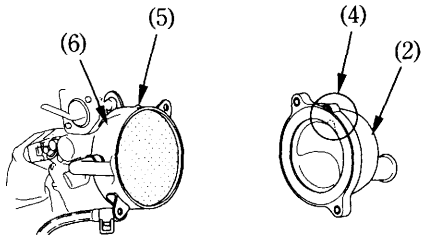

- (2) Air cleaner housing cover
- (4) Projection
- (5) Projection
- (6) Air cleaner housing

ENGINE OIL

Refer to the Safety Precautions on page 48 .

Oil Recommendation

API classification	SG or higher except oils labeled as energy conserving on the circular API service label
Viscosity	SAE 10W-30
JASO T 903 standard	MA

Suggested Oil
Honda "4-STROKE MOTORCYCLE OIL" or equivalent.

Your motorcycle does not need oil additives. Use the recommended oil.

Do not use oils with graphite or molybdenum additives. They may adversely affect clutch operation.

Do not use API SH or higher oils displaying a circular API "energy conserving" service label on the container. They may affect lubrication and clutch performance.



NOT RECOMMENDED

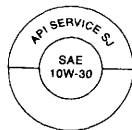

OK

Do not use non-detergent, vegetable, or castor based racing oils.

Viscosity:

Viscosity grade of engine oil should be based on average atmospheric temperature in your riding area. The following provides a guide to the selection of the proper grade or viscosity of oil to be used at various atmospheric temperatures.

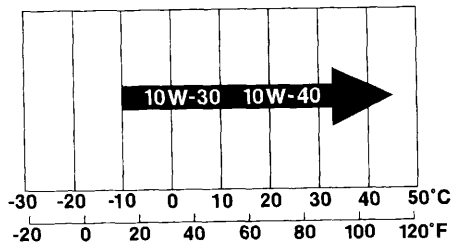

JASO T 903 standard

The JASO T 903 standard is an index for engine oils for 4-stroke motorcycle engines.

There are two classes: MA and MB.

Oil conforming to the standard is labeled on the oil container. For example, the following label shows the MA classification.

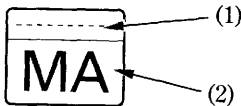

PRODUCT MEETING JASO T 903
COMPANY GUARANTEEING THIS MA PERFORMANCE:

- (1) Code number of the sales company of the oil
- (2) Oil classification

Engine Oil

Engine oil quality is the chief factor affecting engine service life. Change the engine oil as specified in the maintenance schedule (page 50).

When running in very dusty conditions, oil changes should be performed more frequently than specified in the maintenance schedule.

Please dispose of used engine oil in a manner that is compatible with the environment. We suggest you take it in a sealed container to your local recycling center or service station for reclamation. Do not throw it in the trash or pour it on the ground or down a drain.

Used engine oil may cause skin cancer if repeatedly left in contact with the skin for prolonged periods. Although this is unlikely unless you handle used oil on a daily basis, it is still advisable to thoroughly wash your hands with soap and water as soon as possible after handling used oil.

If a torque wrench is not used for this installation, see your Honda dealer as soon as possible to verify proper assembly.

Change the engine oil with the engine at normal operating temperature and the motorcycle on its side stand to assure complete and rapid draining.

1. Remove the oil filler cap/dipstick (1) from the right crankcase cover.
 2. Place a drain pan under the crankcase and remove the oil drain bolt (2).
 3. Operate the kickstarter several times while turned the engine stop switch at \otimes (OFF) to drain any oil which may be left in the engine.
 4. Check that the sealing washer (3) on the drain bolt is in good condition and install the bolt. Replace the sealing washer every other time the oil is changed, or each time if necessary.
- Oil Drain Bolt Torque:
 24 N·m (2.5 kgf·m , 18 lbf·ft)
5. Fill the crankcase with the recommended grade oil; approximately:
 0.6 l (0.6 US qt , 0.5 Imp qt)

6. Reinstall the oil filler cap/dipstick.
7. Start the engine and let it idle for 2–3 minutes.
8. Stop the engine and check that the oil level is at the upper level mark on the oil filler cap/dipstick with the motorcycle upright on firm, level ground.
 Make sure there are no oil leaks.

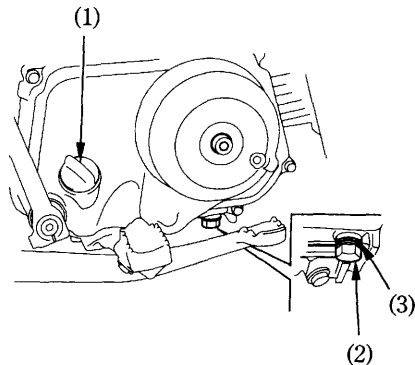

- | | |
|-----------------------------|--------------------|
| (1) Oil filler cap/dipstick | (3) Sealing washer |
| (2) Oil drain bolt | |

SPARK PLUG

Refer to the Safety Precautions on page 48 .

Recommended plugs:

Standard:

CR6HSA (NGK) or
U20FSR-U (DENSO)

For cold climate: (Below 5°C, 41°F)

CR5HSA (NGK) or
U16FSR-U (DENSO)

For extended high speed riding:

CR7HSA (NGK) or
U22FSR-U (DENSO)

For most riding conditions this spark plug heat range number is satisfactory. However, if the motorcycle is going to be operated for extended periods at high speeds or near maximum power in hot climates, the spark plug should be changed to a colder heat range (a higher number).

NOTICE

Never use a spark plug with an improper heat range. Severe engine damage could result.

1. Disconnect the spark plug cap.
2. Clean any dirt from around the spark plug base.
3. Remove the spark plug.
4. Visually inspect the spark plug electrodes for wear. The center electrode should have square edges and the side electrode should not be eroded.
5. Discard the spark plug if there is apparent wear or if the insulator is cracked or chipped.

6. Check the spark plug gap (1) using a wire-type feeler gauge. If adjustment is necessary, bend the side electrode (2) carefully.

The gap should be:

0.60–0.70 mm (0.024–0.028 in)

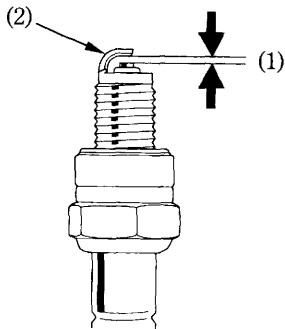

(1) Spark plug gap

(2) Side electrode

7. Make sure the plug washer is in good condition.
8. With the plug washer attached, thread the spark plug in by hand to prevent cross-threading.
9. Tighten the spark plug:
- If the old plug is good:
1/8 turn after it seats.
 - If installing a new plug, tighten it twice to prevent loosening:
 - a) First, tighten the plug:
NGK: 1 turn after it seats.
DENSO: 3/4 turn after it seats.
 - b) Then loosen the plug.
 - c) Next, tighten the plug again:
1/8 turn after it seats.

NOTICE

An improperly tightened spark plug can damage the engine. If a plug is too loose, a piston may be damaged. If a plug is too tight, the threads may be damaged.

10. Reinstall the spark plug cap. Take care to avoid pinching any cables or wires.

IDLE SPEED

Refer to the Safety Precautions on page 48 .

Idle Speed:

The engine must be at normal operating temperature for accurate idle speed adjustment. 10 minutes of stop-and-go riding is sufficient.

Do not attempt to compensate for faults in other systems by adjusting idle speed. See your Honda dealer for regularly scheduled carburetor adjustments.

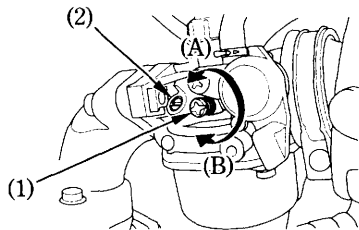

- | | |
|-------------------------|--------------|
| (1) Throttle stop screw | (A) Decrease |
| (2) Air screw | (B) Increase |

1. Warm up the engine and hold the motorcycle upright.
2. Connect a tachometer to the engine.
3. Adjust idle speed with the throttle stop screw (1).

Idle speed (In neutral):

$$1,700 \pm 100 \text{ min}^{-1} (\text{rpm})$$

Idle Mixture:

1. Adjust the fuel mixture by turning the air screw (2) clockwise until you hear the engine miss or decrease in speed, then counterclockwise until the engine again misses or decreases in speed. Set the air screw exactly between these two extreme positions.

From a fully closed position, the correct setting (between extremes of rich and lean) will be approximately:

$$1-1/2$$

2. If the idle speed changes after adjusting fuel mixture, readjust the idle speed by turning the throttle stop screw.

THROTTLE OPERATION

Refer to the Safety Precautions on page 48 .

Cable Inspection:

1. Check for smooth rotation of the throttle grip from the fully open to the fully closed position at both full steering positions.
2. Inspect the condition of the throttle cable (1) from the throttle grip down to the carburetor. If the cable is kinked, chafed or improperly routed, it should be replaced and/or rerouted.
3. Lubricate the cable with a commercially available cable lubricant to prevent premature wear and corrosion.

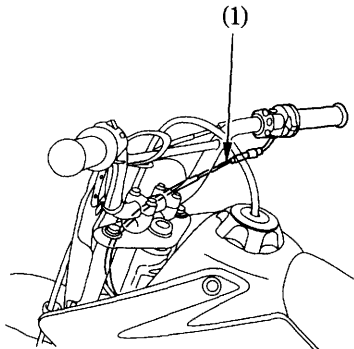

(1) Throttle cable

Freeplay Adjustment:

1. Adjust freeplay with the throttle cable adjuster (1). Measured in grip rotation, the standard throttle grip freeplay is:
2.0 – 6.0 mm (0.08 – 0.24 in)
2. To adjust the freeplay, loosen the lock nut (2) and turn the adjuster.
3. After adjustment, check again for smooth rotation of the throttle grip from the fully closed to the fully open position with the steering to the full right and left as well as straight ahead.

If proper throttle freeplay cannot be achieved, contact your Honda dealer.

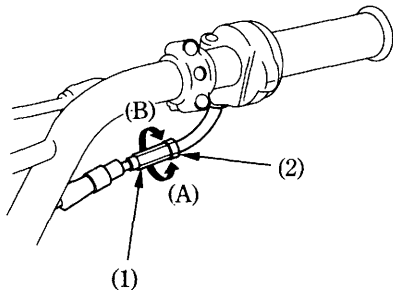

- (1) Cable adjuster
(2) Lock nut

- (A) Decrease freeplay
(B) Increase freeplay

VALVE CLEARANCE

Refer to the Safety Precautions on page 48 .

Excessive valve clearance will cause noise and eventual engine damage. Little or no clearance will prevent the valve from closing and cause valve damage and power loss. Check valve clearance when the engine is cold at the specified intervals.

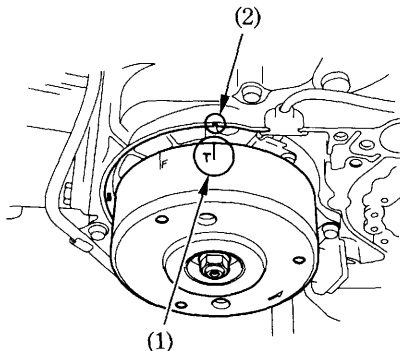

(1) T mark

(2) Index mark

The checking or adjusting of the clearance should be performed while the engine is cold. The clearance will change as the engine temperature rises.

1. Remove the left crankcase cover.
2. Remove the adjusting hole caps.
3. Rotate the flywheel counterclockwise until the T mark (1) on the flywheel lines up with the index mark (2) on the crankcase. In this position, the piston may either be on the compression or exhaust stroke.

The adjustment must be made when the piston is at the top of the compression stroke when both the intake and exhaust valves are closed.

This condition can be determined by moving the rocker arms. If they are free, it is an indication that the valves are closed and that the piston is on the compression stroke. If they are tight and the valves are open, rotate the flywheel 360° and realign the T mark to the index mark.

4. Check the clearance of both valves by inserting a feeler gauge (3) between the adjusting screw (4) and the valve stem.

Clearance should be:

Intake: 0.05 mm (0.002 in)

Exhaust: 0.05 mm (0.002 in)

If it is necessary to make an adjustment, loosen the adjusting screw lock nut (5) and turn the adjusting screw so there is a slight resistance when the feeler gauge is inserted.

After completing the adjustment, tighten the adjusting screw lock nut while holding the adjusting screw to prevent it from turning.

Finally, recheck the clearance to make sure that the adjustment has not been disturbed.

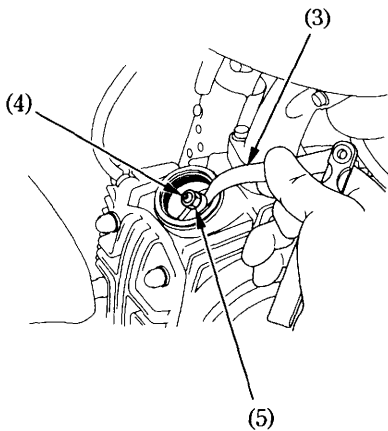

- (3) Feeler gauge
(4) Adjusting screw
(5) Adjusting screw lock nut

SPARK ARRESTER

Refer to the Safety Precautions on page 48 .

The exhaust system spark arrester must be purged of accumulated carbon periodically (see Maintenance Schedule for servicing period, page 51).

The exhaust system becomes very hot during operation and remains hot for a period of time after stopping the engine. Allow the exhaust system to cool before performing this operation.

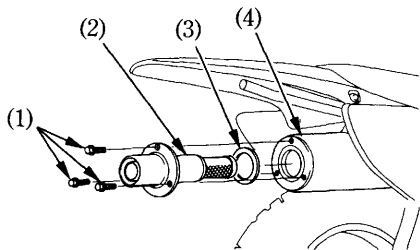

- (1) Bolts
- (2) Spark arrester

- (3) Gasket
- (4) Muffler

1. Remove the bolts (1), the spark arrester (2), and the gasket (3) from the muffler (4).
2. Use a brush to remove carbon deposits from the spark arrester screen. Be careful to avoid damaging the spark arrester screen. The spark arrester must be free of breaks and holes. Replace, if necessary. Check the gasket. Replace, if necessary.
3. Install the spark arrester and the gasket in the muffler and tighten the bolts securely.

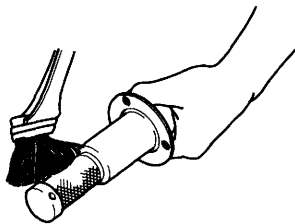

DRIVE CHAIN

Refer to the Safety Precautions on page 48 .

The service life of the drive chain is dependent upon proper lubrication and adjustment. Poor maintenance can cause premature wear or damage to the drive chain and sprockets.

The drive chain should be checked and lubricated as part of the Pre-ride Inspection (page 35). Under severe usage, or when the motorcycle is ridden in unusually dusty or muddy areas, more frequent maintenance will be necessary.

Inspection:

1. Turn the engine off, place the motorcycle on its side stand and shift the transmission into neutral.
2. Check slack in the lower drive chain run midway between the sprockets.
Drive chain slack should be adjusted to allow the following vertical movement by hand:

10–20 mm (0.4–0.8 in)

3. Roll the motorcycle forward. Stop. Check the drive chain slack. Repeat this procedure several times. Drive chain slack should remain constant. If the chain is slack only in certain sections, some links are kinked and binding. Binding and kinking can frequently be eliminated by lubrication.

NOTICE

Excessive chain slack may allow the drive chain to damage the engine cases.

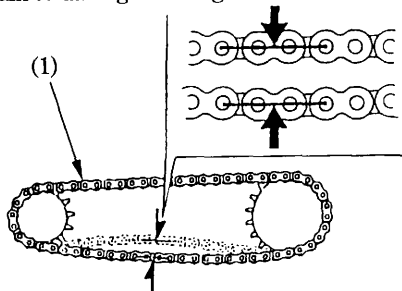

(1) Drive chain

4. Check the chain slider (2) for wear.
If the ridge (3) in the center of the slider is worn, have your Honda dealer replace the chain slider.

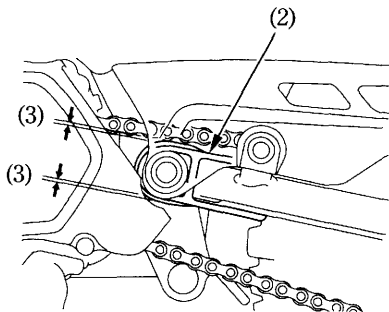

5. Measure a section of the drive chain to determine whether the chain is worn beyond its service limit. Remove the drive chain and measure the distance between a span of pins from pin center to pin center. If the distance exceeds the service limit, the chain is worn out and should be replaced.

New Chain:
1,080 mm (42.5 in)

Service Limit:
1,101 mm (43.3 in)

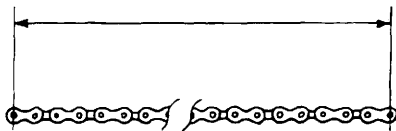

Measure a span of : 85 pins.

- (2) Chain slider
(3) Ridge

6. Inspect the sprocket teeth for possible wear or damage.

Damaged sprocket
Teeth

Replace

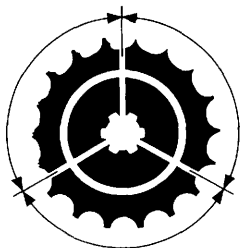

Worn sprocket
Teeth

Replace

Normal sprocket Teeth

GOOD

If the drive chain or sprockets are excessively worn or damaged, they should be replaced. Never use a new chain with worn sprockets; rapid chain wear will result.

Adjustment:

If the drive chain requires adjustment, the procedure is as follows:

1. Place a support block under the engine to raise the rear wheel off the ground.
2. Loosen the rear axle nut (1).

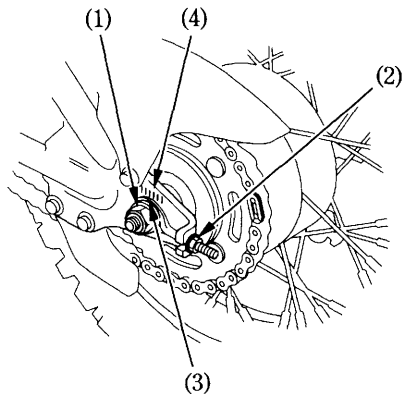

- (1) Rear axle nut
- (2) Adjusting nut

- (3) Adjuster index mark
- (4) Graduated scale

3. Turn the adjusting nut (2) on both the right and left chain adjusters an equal number of turns to increase or decrease chain slack.
Align the chain adjuster index marks (3) with the corresponding scale graduations (4) on both sides of the swingarm.

If the drive chain slack is excessive when the rear axle is moved to the furthest limit of adjustment, the drive chain is worn and must be replaced.

4. Tighten the axle nut to:
59 N·m (6.0 kgf·m , 43 lbf·ft)
5. Tighten the adjusting nuts.
6. Recheck drive chain slack.
7. Rear brake pedal freeplay is affected when repositioning the rear wheel to adjust drive chain slack. Check rear brake pedal freeplay and adjust as necessary (page 18).

If a torque wrench is not used for this installation, see your Honda dealer as soon as possible to verify proper assembly.

Lubrication:

Use SAE 80 or 90 gear oil or a commercially prepared drive chain lubricants in preference to motor oil or other lubricants. Saturate each chain link joint so that the lubricant penetrates between the link plates, pins, bushings, and rollers.

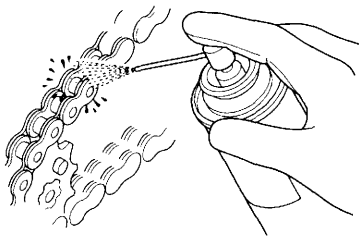

Removal and Cleaning:

When the drive chain becomes dirty, it should be removed and cleaned prior to lubrication.

1. With the engine off, carefully remove the master link retaining clip (1) with a pair of pliers. Do not bend or twist the clip. Remove the master link. Remove the drive chain from the motorcycle.
2. Clean the drive chain in high flash-point solvent and allow it to dry. Inspect the drive chain for possible wear or damage. Replace any chain that has damaged rollers, loose fitting links, or otherwise appears unserviceable.

Never use petrol or low flash point solvents for cleaning the drive chain. A fire or explosion could result.

3. Inspect the sprocket teeth for possible wear or damage.
4. Lubricate the drive chain (page 73).

5. Pass the chain over the sprockets and join the ends of the chain with the master link. For ease of assembly, hold the chain ends against adjacent rear sprocket teeth while inserting the master link.

The master link is the most critical part affecting the security of the drive chain. Master links are reusable, if they remain in excellent condition, but it is recommended that a new master link retaining clip be installed whenever the drive chain is reassembled.

Install the master link retaining clip so that the closed end of the clip will face the direction of forward wheel rotation.

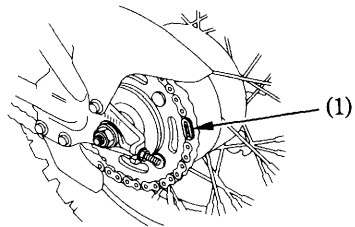

(1) Retaining clip

WHEEL RIMS AND SPOKES

Refer to the Safety Precautions on page 48 .

1. Inspect the wheel rims (1) and spokes (2) for damage.
2. Tighten any loose spokes.
3. Check wheel rim runout. If runout is noticeable, see your Honda dealer for inspection.

Maintenance of spoke tension and wheel trueness are critical to safe motorcycle operation. During the first 150 km (100 miles), spokes will loosen more rapidly due to initial seating of parts. Excessively loose spokes may result in high speed instability and possible loss of control.

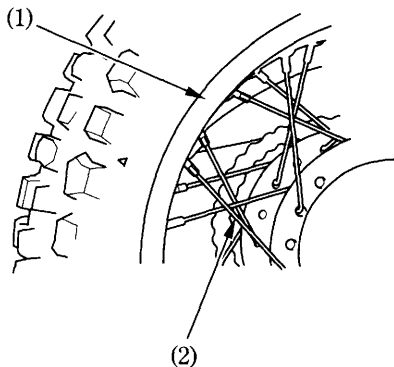

- (1) Wheel rim
(2) Spoke

WHEEL REMOVAL

Refer to the Safety Precautions on page 48 .

Front Wheel Removal

1. Raise the front wheel off the ground by placing a support block under the engine.
2. Loosen the cable guide bolt (1).
3. Disconnect the front brake cable (2) from the brake arm (3).
4. Remove the front axle nut (4) and front axle. The front wheel can now be removed.

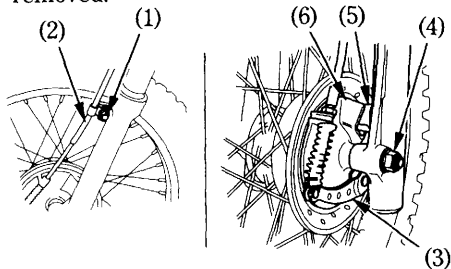

- (1) Cable guide bolt
(2) Front brake cable
(3) Brake arm

- (4) Front axle nut
(5) Lug
(6) Slot

Installation:

1. Reverse the removal procedure. Make sure that the lug (5) on the fork leg is located in the slot (6) in the brake panel. Be sure to tighten the axle nut to:
59 N·m (6.0 kgf·m , 43 lbf·ft)
2. Check front brake adjustment.
3. After installing the wheel, apply the brake several times and then check if the wheel rotates freely. Recheck the wheel if the brake drags or if the wheel does not rotate freely.

If a torque wrench was not used for installation, see your Honda dealer as soon as possible to verify proper assembly. Improper assembly may lead to loss of braking capacity.

Rear Wheel Removal

1. Raise the rear wheel off the ground by placing a support block under the engine.
2. Unscrew the rear brake adjuster (1).
3. Press and release the rear brake pedal and disconnect the brake rod (2) from the brake arm (3).
4. Loosen the adjusting nut (4) on the chain adjuster on both sides.

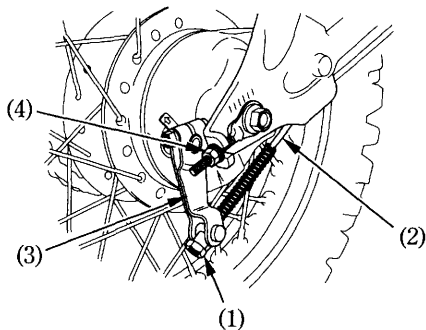

(1) Brake adjuster
(2) Brake rod

(3) Brake arm
(4) Adjusting nut

5. Unscrew the axle nut (5) and pull out the axle. Push the wheel forward and derail the drive chain from the rear sprocket. Tilt the motorcycle to one side so that the wheel can be removed.

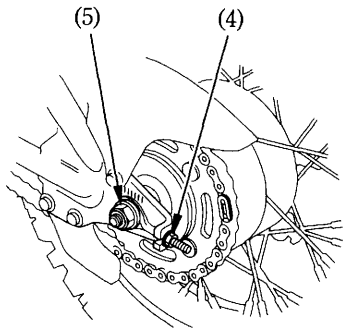

(5) Axle nut

Installation:

1. Reverse the removal procedure. Make sure that the lug (1) on the swingarm is located in the slot (2) in the brake panel. Tighten the axle nut to:
59 N·m (6.0 kgf·m , 43 lbf·ft)
2. Adjust the drive chain (pages 72 – 73).
3. Adjust the brake (page 18).
4. Apply the brake several times and check for free wheel rotation after the brake pedal is released.

If a torque wrench was not used for installation, see your Honda dealer as soon as possible to verify proper assembly. Improper assembly may lead to loss of braking capacity.

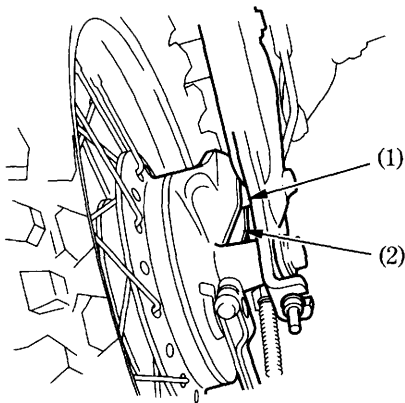

(1) Lug

(2) Slot