

2006

OWNER'S MANUAL

CRF80F

**CRF**

 **HONDA**



**2006  
Honda CRF80F  
OWNER'S MANUAL**

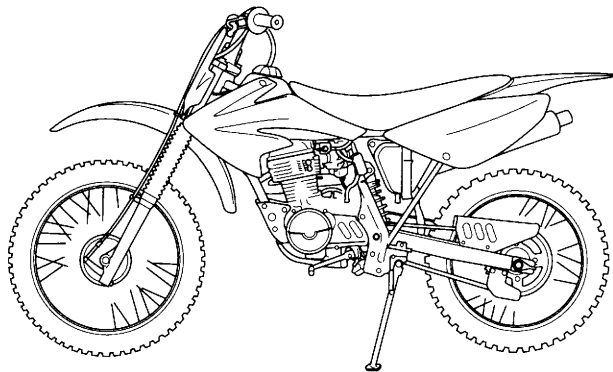

**FOR OFF-ROAD USE ONLY**

This vehicle is designed and manufactured for off-road use only.

USA only:

It conforms to US EPA Noise Emission regulations, but does not conform to Federal Motor Vehicle Safety Standards or US EPA On Highway Exhaust Emission regulations, and operation on public streets, roads, or highways is illegal. The vehicle is equipped with a USDA qualified spark arrester. Obey local laws and regulations.

It conforms to US EPA and California exhaust emission regulations for off-road motorcycles.

# A Few Words About Safety

---

Your safety, and the safety of others, is very important. And operating this motorcycle safely is an important responsibility.

To help you make informed decisions about safety, we have provided operating procedures and other information on labels and in this manual. This information alerts you to potential hazards that could hurt you or others.

Of course, it is not practical or possible to warn you about all hazards associated with operating or maintaining a motorcycle. You must use your own good judgment.

You will find important safety information in a variety of forms, including:

- **Safety Labels** — on the motorcycle.
- **Safety Messages** — preceded by a safety alert symbol  and one of three signal words: **DANGER, WARNING, or CAUTION.**

These signal words mean:

## Safety Messages

## A Few Words About Safety

---

### **▲ DANGER**

You **WILL** be **KILLED** or **SERIOUSLY HURT** if you don't follow instructions.

### **▲ WARNING**

You **CAN** be **KILLED** or **SERIOUSLY HURT** if you don't follow instructions.

### **▲ CAUTION**

You **CAN** be **HURT** if you don't follow instructions.

- **Safety Headings** — such as Important Safety Reminders or Important Safety Precautions.
- **Safety Section** — such as Motorcycle Safety.
- **Instructions** — how to use this motorcycle correctly and safely.

This entire book is filled with important safety information — please read it carefully.

# Contents

---

These pages give an overview of the contents of your owner's manual. The first page of each section lists the topics covered in that section.

## Introduction

### **Motorcycle Safety ..... 1**

Important safety information, a special message for parents, precautions about loading, accessories, and modifications, and the location of safety labels.

### **Operating Controls ..... 13**

The location, function, and operation of the throttle, brakes, clutch, and other basic controls.

### **Before Riding ..... 23**

The importance of wearing a helmet and other protective gear, plus how to make sure you and your motorcycle are ready to ride.

### **Basic Operation & Riding ..... 29**

How to start and stop the engine, shift gears, and brake. Also, riding precautions.

### **Servicing Your Honda ..... 41**

Why your motorcycle needs regular maintenance, what you need to know before servicing your Honda, a maintenance schedule, and instructions for specific maintenance items.

<b>Tips</b> .....	<b>109</b>
How to transport and store your motorcycle, and how to be an environmentally-responsible rider.	
<b>Taking Care of the Unexpected</b> .....	<b>119</b>
What to do if you have a flat tire, your engine won't start, etc.	
<b>Technical Information</b> .....	<b>127</b>
ID numbers, technical specifications, and other technical facts.	
<b>Consumer Information</b> .....	<b>143</b>
Information on warranties and how to get Honda service manuals.	
<b>Table of Contents</b> .....	<b>152</b>
Sequential listing of topics in this owner's manual.	
<b>Index</b> .....	<b>156</b>

## Quick Reference

Handy facts about fuel, engine oil, tire sizes, and air pressures.

# Introduction

---

Congratulations on choosing your Honda off-road motorcycle.

When you own a Honda, you're part of a worldwide family of satisfied customers — people who appreciate Honda's reputation for building quality into every product.

Your Honda was designed as a recreational motorcycle for off-road use by one rider only. It's an ideal bike for younger, beginning riders.

Before riding, take time to get acquainted with your motorcycle and how it works. To protect your investment, we urge you to take responsibility for keeping your motorcycle well maintained. Scheduled service is a must, of course. But it's just as important to observe the break-in guidelines, and perform all the pre-ride and other periodic checks detailed in this manual.

We also recommend that you read the owner's manual before you ride. It's full of facts, instructions, safety information, and helpful tips. To make it easy to use, the manual contains a table of contents, a detailed list of topics at the beginning of each section, and an index at the back of the book.

As you read this manual, you will find information that is preceded by a **NOTICE** symbol. This information is intended to help you avoid damage to your Honda, other property, or the environment.

Read the Warranties Booklet (page 147 ) thoroughly so you understand the coverages that protect your new Honda and are aware of your rights and responsibilities.

# Introduction

---

Whenever you ride, tread lightly. By staying on established trails and riding only in approved areas, you help protect the environment and keep off-road riding areas open for the future.

If you have any questions, or if you ever need a special service or repairs, remember that your Honda dealer knows your motorcycle best and is dedicated to your complete satisfaction.

Please report any change of address or ownership to your Honda dealer so we will be able to contact you concerning important production information.

You may also want to visit our website at [www.honda.com](http://www.honda.com).

Happy riding!

## California Proposition 65 Warning

**WARNING:** This product contains or emits chemicals known to the State of California to cause cancer and birth defects or other reproductive harm.



# Motorcycle Safety

---

This section presents some of the most important information and recommendations to help you ride your motorcycle safely. Please take a few moments to read these pages. This section also includes a special message for parents and location information for the safety labels on your motorcycle.

Important Safety Information .....	2
Important Message to Parents .....	5
Loading, Accessories & Modifications .....	8
Loading .....	8
Accessories & Modifications.....	10
Safety Labels.....	12

# Important Safety Information

---

Your motorcycle can provide many years of service and pleasure — if you take responsibility for your own safety and understand the challenges you can meet while riding.

This motorcycle has been designed for younger riders, as well as for smaller adults. However, not all youngsters are physically or emotionally ready to ride. Therefore, before parents allow any youngster to ride this motorcycle, we urge them to carefully read the *Important Message to Parents* beginning on page 5 and the *Parents, Youngsters and Off-Highway Motorcycles* booklet that came with the motorcycle (USA only).

There is much that you can do to protect yourself when you ride. You'll find many helpful recommendations throughout this manual. The following are a few that we consider most important.

## **Always Wear a Helmet**

It's a proven fact: helmets significantly reduce the number and severity of head injuries. So always wear an approved motorcycle helmet. We also recommend that you wear eye protection, sturdy boots, gloves, and other protective gear (page 24).

## **Never Carry a Passenger**

Your motorcycle is designed for one person only. There are no handholds, footrests, or seat for a second person — so never carry a passenger. A passenger could interfere with your ability to move around to maintain your balance and control of the motorcycle.

# Important Safety Information

---

## **Ride Off-Road Only**

Your motorcycle is designed and manufactured for off-road use only. The tires are not made for pavement, and the motorcycle does not have turn signals and other features required for use on public roads. If you need to cross a paved or public road, get off and walk your motorcycle across.

## **Take Time to Learn and Practice**

Developing off-road riding skills is a gradual, step-by-step process. Start by practicing at low speeds in a safe area and slowly build your skills. Personal instruction from an experienced rider can also be valuable.

If you need assistance, ask your dealer about riding groups in your area.

Also be sure to read the *Tips & Practice Guide for the Off-Highway Motorcyclist* booklet that came with your motorcycle (USA only).

## **Be Alert for Off-Road Hazards**

The terrain can present a variety of challenges when you ride off-road. Continually “read” the terrain for unexpected turns, drop-offs, rocks, ruts, and other hazards. Always keep your speed low enough to allow time to see and react to hazards.

## **Ride within Your Limits**

Pushing limits is another major cause of motorcycle accidents. Never ride beyond your personal abilities or faster than conditions warrant. Remember that alcohol, drugs, fatigue, and inattention can significantly reduce your ability to make good judgments and ride safely.

# Important Safety Information

---

## **Don't Drink and Ride**

Alcohol and riding don't mix. Even one drink can reduce your ability to respond to changing conditions, and your reaction time gets worse with every additional drink. So don't drink and ride, and don't let your friends drink and ride either.

## **Keep Your Honda in Safe Condition**

It's important to keep your motorcycle properly maintained and in safe riding condition. Having a breakdown can be difficult, especially if you are stranded off-road far from your base. To help avoid problems, inspect your motorcycle before every ride and perform all recommended maintenance.

# Important Message to Parents

---

Your child's safety is very important to Honda. That's why we urge you to read this message before you let any young person ride this motorcycle. Off-road riding can be fun. But, as with riding a bicycle, bad judgment can result in injury, and we don't want that to happen! As a parent, you can help prevent accidents by making good decisions about if, when, and how your youngster rides this motorcycle.

## Riding Readiness

The first decision you'll need to make is whether your youngster is ready to ride. Riding readiness varies widely from one person to another, and age and size are not the only factors.

**PHYSICAL ABILITY** is an important consideration. For example, riders must be big enough to hold the motorcycle up, get on, and comfortably sit on the seat with both feet touching the ground. They should also be able to easily reach and work the brakes, throttle, and all other controls.

**ATHLETIC ABILITY** is necessary for riding a motorcycle. Generally speaking, your youngster should be good at riding a bicycle before getting on a motorcycle. Can your youngster judge speeds and distances while riding a bicycle and react with proper hand and foot actions? Anyone who does not have good coordination, balance, and agility is not ready to ride this motorcycle.

(cont'd)

# Important Message to Parents

---

MENTAL AND EMOTIONAL MATURITY are requirements for safe riding. Does your youngster think through problems and come to logical solutions? On a bicycle, does your youngster obey safe riding rules? Be honest! Young people who take unnecessary risks, make bad judgments, and don't obey rules are not ready to ride this motorcycle.

## Instruction and Supervision

If you decide that your youngster is ready to safely operate this motorcycle, make sure both of you carefully read and understand the owner's manual before riding. Also be sure that your youngster has a helmet and other appropriate riding equipment and always wears it when operating the vehicle or sitting on it.

GOOD INSTRUCTION is an important part of hands-on training. The teacher can either be you or another responsible adult who has experience with off-road motorcycle riding. (For help in finding a qualified instructor, talk with your Honda dealer.) Even if you're not the main teacher, it's up to you to ensure your youngster's safety. Remember, learning to ride a motorcycle is a gradual, step-by-step process. It takes time, patience, and practice — many hours over a period of weeks or months.

## Important Message to Parents

---

**SUPERVISION** is another important obligation of parents. Even after youngsters have become skilled off-road riders, they should always ride with adult supervision. It helps to regularly remind young riders of basic safety rules and precautions. And remember, it's your responsibility to see that the motorcycle is properly maintained and kept in safe operating condition.

**SAFE AND RESPONSIBLE RIDING** must be an on-going commitment – by you and your youngster. When you both put safety first, you can enjoy more peace of mind, and your youngster can enjoy more hours of safe off-road riding.

For your convenience, this CRF80F comes with an ignition switch and key. Remove the key when the motorcycle is parked to help prevent unauthorized use.

# Loading, Accessories & Modifications

---

Your Honda was designed as a rider-only motorcycle. It was not designed to carry a passenger or cargo. A passenger or cargo could interfere with your ability to move around to maintain your balance and control of the motorcycle.

In addition, exceeding the weight limits or carrying an unbalanced load can seriously affect your motorcycle's handling, braking, and stability. Adding accessories or making modifications that change this motorcycle's design and performance can also make it unsafe. Also, the weight of any accessories will reduce the maximum load the motorcycle can carry.

More specific information on load limits, accessories, and modifications follows.

## Loading

How much weight you put on your motorcycle, and how you load it, are important to your safety. If you decide to carry cargo, you should be aware of the following information.

### **⚠ WARNING**

Overloading or carrying a passenger can cause a crash and you can be seriously hurt or killed.

Follow all load limits and other loading guidelines in this manual.

# Loading, Accessories & Modifications

---

## **Load Limits**

Following are the load limits for your motorcycle:

### **Maximum weight capacity**

= 220 lbs (100 kg)

Includes the weight of the rider and any accessories.

## **Loading Guidelines**

As discussed on page 8, we recommend that you do not carry any cargo on this motorcycle. However, if you decide to carry cargo, ride at reduced speeds and follow these common-sense guidelines:

- Keep cargo small and light. Make sure it cannot easily be caught on brush or other objects, and that it does not interfere with your ability to shift position to maintain balance and stability.

- Place weight as close to the center of the motorcycle as possible.
- Do not attach large or heavy items (such as a sleeping bag or tent) to the handlebar, fork, or front fender.
- Make sure that all cargo is tied down securely.
- Never exceed the maximum weight limit.
- Check that both tires are inflated properly.

# Loading, Accessories & Modifications

---

## Accessories & Modifications

Modifying your motorcycle or using non-Honda accessories can make your motorcycle unsafe.

Before you consider making any modifications or adding an accessory, be sure to read the following information.

### **⚠ WARNING**

Improper accessories or modifications can cause a crash in which you can be seriously hurt or killed.

Follow all instructions in this owner's manual regarding modifications and accessories.

## Accessories

We strongly recommend that you use only genuine Honda accessories that have been specifically designed and tested for your motorcycle. Because Honda cannot test all other accessories, you must be personally responsible for proper selection, installation, and use of non-Honda accessories. Check with your dealer for assistance and always follow this guideline:

- Make sure the accessory does not reduce ground clearance and lean angle, limit suspension travel or steering travel, alter your riding position, or interfere with operating any controls.

# Loading, Accessories & Modifications

---

## Modifications

We strongly advise you not to remove any original equipment or modify your motorcycle in any way that would change its design or operation. Such changes could seriously impair your motorcycle's handling, stability, and braking, making it unsafe to ride.

We also advise you not to make any modifications or remove any equipment (such as the USDA qualified spark arrester or emission control system components) that would make the motorcycle illegal in your area.

# Safety Labels

---

This page shows the locations of safety labels on your motorcycle. Some labels warn you of potential hazards that could cause serious injury. Others provide important safety information. Read these labels carefully and don't remove them.

If a label comes off or becomes hard to read, contact your Honda dealer for a replacement.

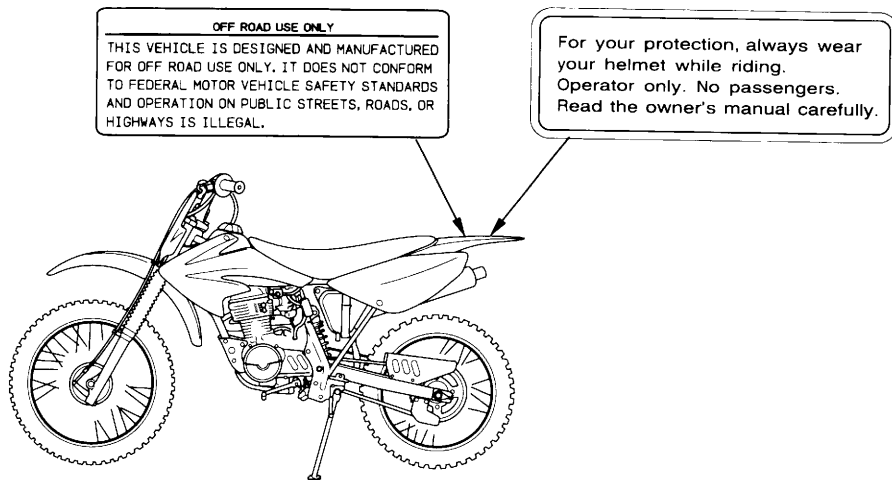

# Operating Controls

---

When you ride off-road, you need to operate the throttle, clutch, brakes, and other controls without stopping to look at them. Read this section carefully before you ride. It describes the location, function, and operation of all the basic controls on your motorcycle.

Operation Component Locations.....	14
Operating Controls.....	17
Fuel Valve.....	17
Choke Lever.....	18
Ignition Switch.....	19
Engine Stop Button.....	20
Front Brake Lever.....	20
Throttle.....	20
Clutch Lever.....	20
Shift Lever.....	21
Rear Brake Pedal.....	21
Kickstarter.....	21
Side Stand.....	21

# Operation Component Locations

---

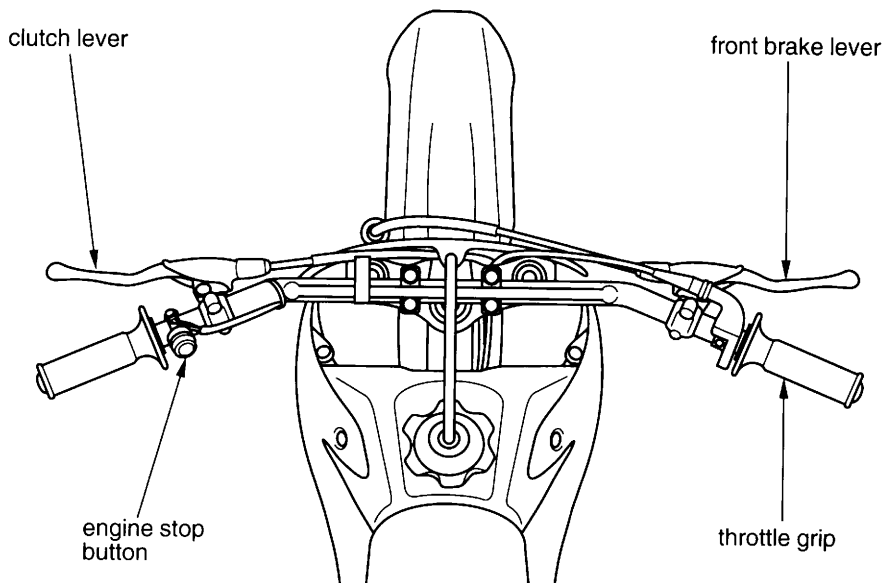

# Operation Component Locations

---

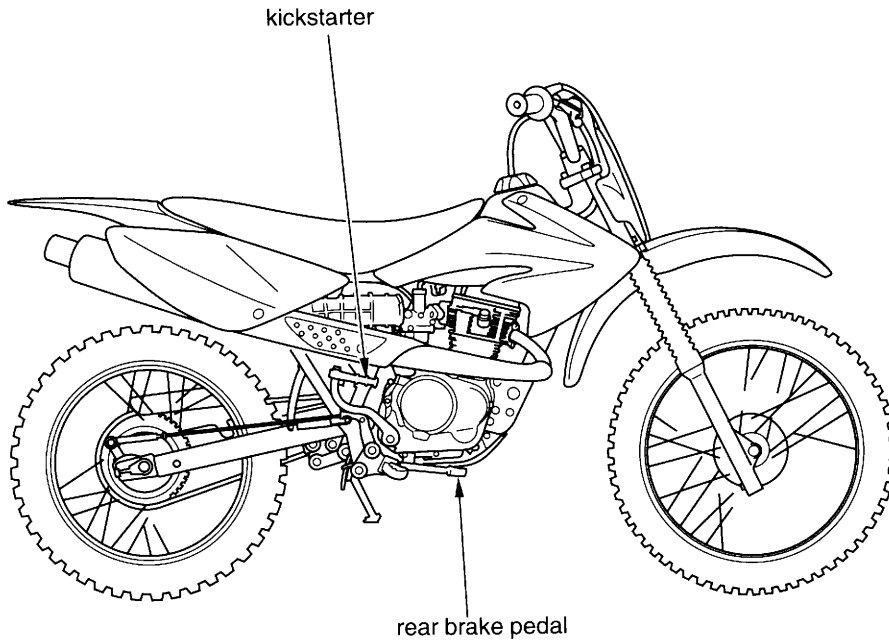

# Operation Component Locations

---

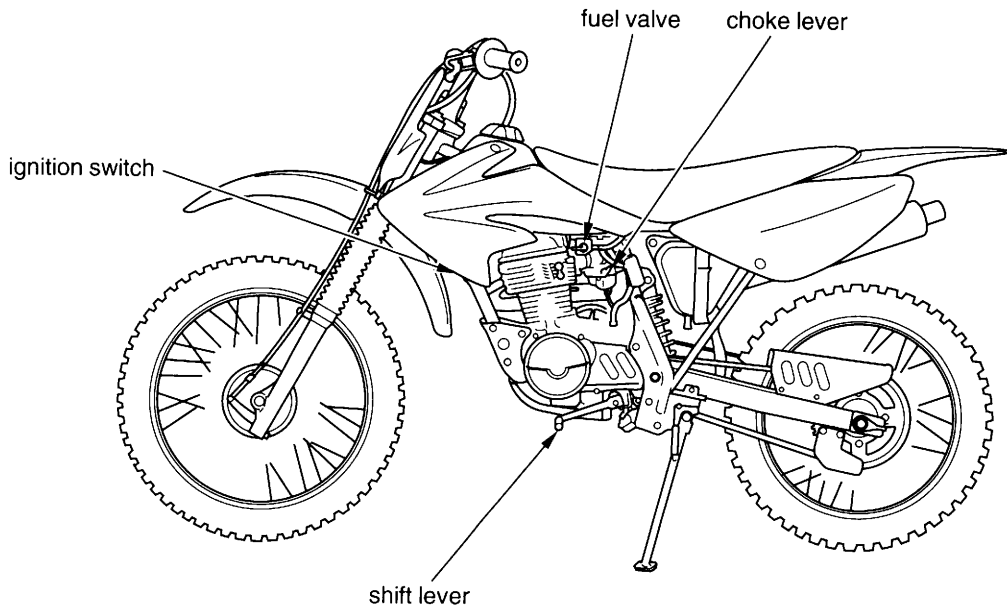

## Fuel Valve

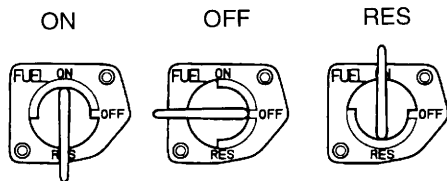

The three-way fuel valve is used to control the flow of fuel from the fuel tank to the carburetor.

### ON

Turning the fuel valve ON before attempting to start the engine allows fuel to flow from the fuel tank to the carburetor.

### OFF

Turning the fuel valve OFF after stopping the engine prevents the flow of fuel from the fuel tank to the carburetor.

### RES

Turning the fuel valve to RES allows fuel to flow from the reserve fuel supply to the carburetor.

# Operating Controls

---

The reserve fuel supply is:  
0.29 US gal (1.1 ℓ)

The tank should be refilled as soon as possible after switching to reserve, and the fuel valve should be returned to the ON position after refueling to avoid running out of fuel with no reserve.

## Choke Lever

LEFT  
SIDE

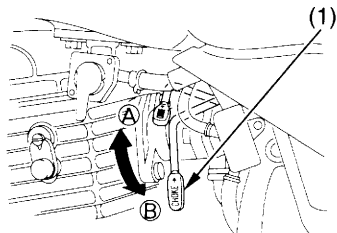

(1) choke lever

(A) fully ON  
(B) fully OFF

The choke lever is used for starting the engine (page 31 ). The choke increases the percentage of fuel in the fuel/air mixture delivered to the engine.

**ON**

Used to start a cold engine with air temperature below 35°C (95°F).

**OFF**

Used for normal operation, for restarting a warm engine, or starting a cold engine with air temperature above 35°C (95°F).

## Ignition Switch

The ignition switch (1) is used to prevent unauthorized use of the motorcycle.

Before riding, insert the key and turn it to the right for the ON position.

Key Position	Function	Key Removal
OFF	The engine cannot be operated.	The key can be removed.
ON	With the transmission in neutral, the engine can be started.	The key cannot be removed.

After parking the motorcycle, remove the key.

LEFT SIDE (under fuel tank)

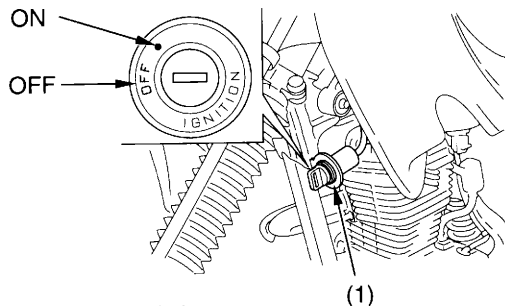

(1) ignition switch

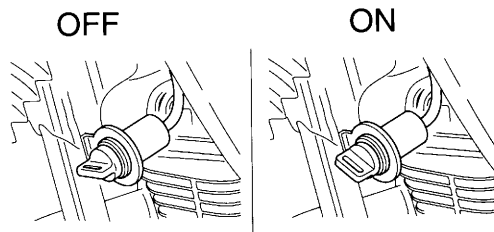

# Operating Controls

---

## Engine Stop Button

The engine stop button is used to turn the engine off during normal riding situations. To operate, push the button in and hold it in until the engine stops completely.

## Front Brake Lever

The front brake lever is used to slow or stop your motorcycle. To operate, pull the lever. For information on braking techniques, see page 36.

## Throttle

The throttle controls engine rpm (speed). To increase engine rpm, rotate the grip toward you. To reduce engine rpm, rotate the grip away from you. The throttle will automatically return to the closed position (engine idle) when you remove your hand.

## Clutch Lever

The clutch lever is used to disengage the clutch whenever you shift gears. To operate, pull the clutch lever in all the way before shifting, then slowly release it after shifting.

## Shift Lever

The shift lever is used to select the next higher or lower gear in the transmission. To operate, raise the shift lever (after pulling in the clutch lever) to engage the next higher gear or depress the shift lever to engage the next lower gear. See *Shifting Gears*, page 34 .

## Rear Brake Pedal

The rear brake pedal is used to slow or stop your motorcycle. To operate, depress the pedal. For information on braking techniques, see page 36 .

## Kickstarter

The kickstarter is used to start the engine. To operate, swing the kickstarter out from its stored position and depress it through its entire stroke. See *Starting Procedure*, page 31 .

## Side Stand

The side stand is used to support your motorcycle while parked (page 38 ). To operate, use your foot to lower the stand. Before riding, raise the stand.



Before each ride, you need to make sure you and your Honda are both ready to ride. To help get you prepared, this section discusses how to evaluate your riding readiness, and how to perform the recommended pre-ride inspection of your Honda. If you're a parent, be sure you also read the *Important Message to Parents* on page 5.

Are You Ready to Ride ? .....	24
Protective Apparel .....	24
Is Your Motorcycle Ready to Ride ? .....	26
Pre-ride Inspection .....	27

# Are You Ready to Ride?

---

Before you ride your motorcycle for the first time, we strongly recommend that you:

- read this owner's manual
- make sure you understand all the safety messages
- know how to operate all the controls

Before each ride, we also suggest that you make sure you:

- are in good physical and mental condition
- are free of alcohol and drugs
- are wearing an approved motorcycle helmet (with chin strap tightened securely), eye protection, and other protective clothing

## Protective Apparel

For your safety, we strongly recommend that you always wear an approved motorcycle helmet, eye protection, boots, gloves, long pants, and a long-sleeved jersey, shirt, or jacket whenever you ride. Although complete protection is not possible, wearing the proper gear can reduce the chance of injury when you ride. Following are suggestions to help you choose the proper gear.

# Are You Ready to Ride?

## **⚠ WARNING**

Not wearing a helmet increases the chance of serious injury or death in a crash.

Be sure you always wear a helmet, eye protection and other protective apparel when you ride.

### **Helmets and Eye Protection**

Your helmet is your most important piece of riding gear because it offers the best protection against head injuries. A helmet should fit your head comfortably and have a chin strap that can be tightened securely.

An open-face helmet offers some protection, but a full-face helmet offers more. Regardless of the style, look for a DOT (Department of Transportation) sticker in any helmet you buy

(USA only). Always wear a face shield or goggles to protect your eyes and help your vision.

### **Additional Riding Gear**

In addition to a helmet and eye protection, we also recommend:

- Sturdy off-road motorcycle boots to help protect your feet, ankles, and lower legs.
- Off-road motorcycle gloves to help protect your hands.
- Riding pants with knee and hip pads, a riding jersey with padded elbows, and a chest/shoulder protector.

# Is Your Motorcycle Ready to Ride?

---

Before each ride, it's important to inspect your motorcycle and make sure any problem you find is corrected. A pre-ride inspection is a must because off-road riding can be tough on a motorcycle and you don't want to have a breakdown far from help.

## **WARNING**

Improperly maintaining this motorcycle or failing to correct a problem before riding can cause a crash in which you can be seriously hurt or killed.

Always perform a pre-ride inspection before every ride and correct any problems.

### *Note to Parents:*

*If a youngster will be performing any of the following pre-ride inspection procedures, it's your responsibility to provide careful supervision and make sure they are performed safely.*

# Is Your Motorcycle Ready to Ride?

## Pre-ride Inspection

Check the following items before you get on the motorcycle:

<i>Tires</i>	Use a gauge to check the air pressure. Adjust if needed. Also look for signs of damage or excessive wear (page 94 ).
<i>Spokes &amp; Rims</i>	Make sure the spokes and rim locks are tight. Also check the rims for damage (page 89 ).
<i>Leaks</i>	Look under the motorcycle for signs of leaking fluids (fuel, engine oil).
<i>Engine Oil</i>	Check the level and add oil if needed (page 63 ).

<i>Fuel</i>	Check the level and add fuel (page 57 ) if needed. Also make sure the fuel fill cap is securely fastened.
<i>Drive Chain</i>	Check the condition and slack. Adjust and lubricate if needed. Also check the chain slider for wear and replace if needed (page 99).
<i>Cables</i>	Check the cable housings for wear. Check the fittings for looseness. Replace or tighten as needed.
<i>Nuts &amp; Bolts</i>	Use a wrench to make sure all accessible nuts, bolts, and fasteners are tight.
<i>Spark Plug &amp; Cap</i>	Check for looseness (page 76 ).

# Is Your Motorcycle Ready to Ride?

---

Check these items after you get on the motorcycle:

*Throttle*      Check the freeplay and adjust if needed. Rotate the throttle to make sure it moves smoothly without sticking, and snaps shut automatically when it is released, in all steering positions (page 69 ).

*Brakes*      Squeeze the front brake lever and step on the rear brake pedal to check that the controls operate normally (page 83 ). Adjust freeplay, if necessary. (pages 83 , 85 ).

*Clutch Lever*      Check for smooth operation and adjust if needed (page 71 ).

Remember, be sure to take care of any problem you find or have your Honda dealer correct it before you ride.

# Basic Operation & Riding

This section gives basic information on how to begin riding your motorcycle. It includes how to start and stop your engine, how to use the throttle, clutch, and brakes, and what to do when you're through riding.

For more advanced information — how to make turns, ride on hills, etc., see the *Tips & Practice Guide for the Off-Highway Motorcyclist* booklet that came with your Honda (USA only).

To protect your new engine and enjoy optimum performance and service life, refer to Break-in Guidelines (page 135 ).

For information about carburetor adjustment for riding at high altitude, see page 136 .

Safe Riding Precautions.....	30
Starting & Stopping the Engine.....	31
Preparation .....	31
Starting Procedure.....	31
Flooded Engine .....	33
How to Stop the Engine.....	33
Shifting Gears .....	34
Braking.....	36
Parking .....	38
Post-ride Inspection .....	39

# Basic Operation & Riding

---

## Safe Riding Precautions

Before riding your motorcycle for the first time, please review the *Important Safety Information* beginning on page 2 and the previous section, titled *Before Riding*.

Even if you have ridden other motorcycles, take time to become familiar with how this motorcycle works and handles. Practice in a safe area until you build up your skills and get accustomed to your motorcycle's size and weight.

For your safety, avoid starting or operating the engine in an enclosed area such as a garage. Your motorcycle's exhaust contains poisonous carbon monoxide gas which can collect rapidly in an enclosed area and cause illness or death.

Your motorcycle is not equipped with lights. Do not ride at night.

# Starting & Stopping the Engine

Always follow the proper starting procedure described below.

Your motorcycle can be kickstarted with the transmission in gear by pulling in the clutch lever before operating the kickstarter.

## Preparation

Before starting, insert the key and turn the ignition switch ON.

Make sure that the transmission is in neutral. Turn the fuel valve ON.

## Starting Procedure

To restart a warm engine, follow the procedure for *High Air Temperature*.

Normal Air Temperature  
10°–35°C (50°–95°F)

LEFT  
SIDE

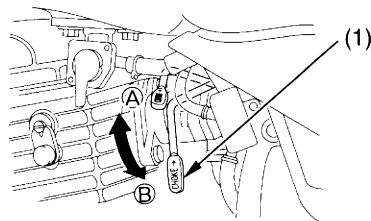

(1) choke lever      (A) fully ON (B) fully OFF

1. Pull the choke lever (1) up all the way to fully ON (A).

(cont'd)

# Starting & Stopping the Engine

---

2. With the throttle slightly open, operate the kickstarter. Kick from the top of the stroke through to the bottom with a rapid, continuous motion.

## NOTICE

*Allowing the kickstarter to snap back freely against the pedal stop can damage the engine case.*

3. Warm up the engine by opening and closing the throttle slightly.
4. About a quarter-minute after the engine starts, push the choke lever down all the way to fully OFF (B).
5. If idling is unstable, open the throttle slightly.

## High Air Temperature 35°C (95°F) or above

1. Do not use the choke.
2. Start the engine following step 2 under *Normal Air Temperature*.

## Low Air Temperature 10°C (50°F) or below

1. Follow steps 1 – 2 under *Normal Air Temperature*.
2. Warm up the engine by opening and closing the throttle slightly.
3. Continue warming up the engine until it idles smoothly and responds to the throttle with the choke lever (1) OFF (B).

## NOTICE

*Extended use of the choke may impair piston and cylinder wall lubrication and damage the engine.*

# Starting & Stopping the Engine

---

## Flooded Engine

If the engine fails to start after repeated attempts, it may be flooded with excess fuel. To clear a flooded engine:

1. Push the choke lever down all the way to OFF.
2. Open the throttle fully.
3. While pushing the engine stop button, crank the engine several times with the kickstarter.
4. Release the engine stop button.
5. Follow the *High Air Temperature* starting procedure (page 32 ).

## How to Stop the Engine

To stop the engine, shift into neutral, push the engine stop button in, and hold it in until the engine stops.

# Shifting Gears

---

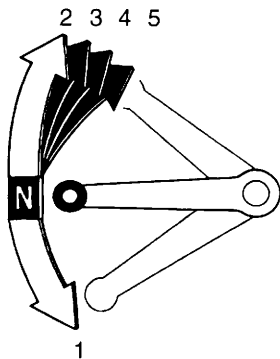

Your motorcycle has five forward gears.

To start riding, after the engine has been warmed and the side stand raised:

1. Close the throttle and pull the front brake lever in.
2. Pull the clutch lever all the way in.

3. Depress the shift lever from neutral down to first gear.
4. Release the front brake. Gradually open the throttle while you slowly release the clutch lever.  
If engine rpm (speed) is too low when you release the clutch lever, the engine will stall. If engine rpm is too high or you release the clutch lever too quickly, your motorcycle may lurch forward.
5. When you attain a moderate speed, close the throttle, pull the clutch lever in, and raise the shift lever. After shifting, release the clutch lever and apply the throttle.

6. To continue shifting up to each higher gear, repeat step 5 .
7. To shift down to a lower gear, close the throttle, pull the clutch lever in, and depress the shift lever. After shifting, release the clutch lever and apply the throttle.

Remember to close the throttle and pull the clutch lever in completely before shifting.

## NOTICE

*Improper shifting may damage the engine, transmission, and drive train.*

Learning when to shift gears comes with experience. Upshift to a higher gear or reduce throttle before engine rpm (speed) gets too high. Downshift to a lower gear before you feel the engine laboring (lugging) at low rpm.

## NOTICE

*Downshifting can help slow your motorcycle, especially on downhills. However, downshifting when engine rpm is too high can cause engine damage.*

## NOTICE

*To prevent transmission damage, do not coast or tow the motorcycle for long distances with the engine off.*

# Braking

---

To slow or stop, apply the front brake and rear brake smoothly, while downshifting to match your speed. Gradually increase braking as you feel the brakes slowing your speed. To prevent stalling the engine, pull the clutch lever in before coming to a complete stop. For support, put your left foot down first, then your right foot when you are through using the rear brake.

For maximum braking, close the throttle and firmly apply the brake lever and pedal controls.

Applying the brakes too hard may cause the wheels to lock and slide, reducing control of your motorcycle. If this happens, release the brake controls, steer straight ahead until you regain control, then reapply the brakes more gently.

Generally, reduce your speed or complete braking before beginning a turn. Avoid braking or closing the throttle quickly while turning. Either action may cause one or both wheels to slip. Any wheel slip will reduce your control of your motorcycle.

When riding in wet or rainy conditions, or on loose surfaces, the ability to maneuver and stop will be reduced. All of your actions should be smooth under these conditions. Rapid acceleration, braking or turning may cause loss of control. For your safety, exercise extreme caution when braking, accelerating, or turning.

When descending a long, steep grade, use engine compression braking by downshifting, with intermittent use of both brakes.

When you brake to a stop, pull the clutch lever in before stopping completely to prevent stalling the engine. For support, put your left foot on the ground first, then your right foot when you're through braking.

# Parking

---

Lower the side stand to support your motorcycle. Turn the ignition switch OFF and remove the key. If you're through riding for the day, also turn the fuel valve OFF. Always choose a level place to park.

## Post-ride Inspection

---

When you return home after riding, thoroughly clean your motorcycle and remove any dirt, mud, brush, rocks or other objects you may have picked up along the way.

After cleaning, carefully inspect your motorcycle for leaks or damage.

Be sure to lubricate the drive chain (page 103) to prevent rusting.



# Servicing Your Honda

Keeping your motorcycle well maintained is absolutely essential to your safety. It's also a good way to protect your investment, get maximum performance, avoid breakdowns, and have more fun.

To help keep your motorcycle in good shape, this section includes a Maintenance Schedule for required servicing and step-by-step instructions for specific maintenance tasks. You'll also find important safety precautions, information on oils, and tips for keeping your Honda looking good.

For information about the exhaust emission and noise emission requirements of the U.S. Environmental Protection Agency (EPA) and the California Air Resources Board (CARB), see page 137 .

USA only

**Maintenance, replacement or repair of the emission control devices and systems may be performed by any motorcycle repair establishment or individual using parts that are "certified" to EPA standards.**

## *Before You Service Your Honda*

The Importance of Maintenance.....	43
Maintenance Safety.....	45
Important Safety Precautions.....	45
Maintenance Schedule .....	47
Maintenance Record .....	51

## *Service Preparations*

Maintenance Component Locations .....	52
Tools.....	55
Side Cover Removal .....	56

(cont'd)

# Servicing Your Honda

---

## *Service Procedures*

### Fluids & Filters

Fuel.....	57
Engine Oil .....	60
Air Cleaner .....	66

### Engine

Throttle.....	69
Clutch System .....	71
Engine Idle Speed .....	75
Spark Plug .....	76
Spark Arrester .....	78

### Chassis

Suspension .....	80
Brakes.....	83
Wheels.....	89
Tires & Tubes.....	94
Side Stand .....	98
Drive Chain .....	99

Appearance Care .....	106
-----------------------	-----

# The Importance of Maintenance

---

A well-maintained motorcycle is essential for safe, economical, and trouble-free riding. It will also help reduce air pollution. Careful pre-ride inspections and good maintenance are especially important because your motorcycle is designed to be ridden over rough off-road terrain.

To help you properly care for your motorcycle, this section of the manual provides a Maintenance Schedule. The service intervals in this schedule are based on average riding conditions.

More frequent service is needed if you subject your motorcycle to severe use (such as competition) or ride in unusually wet or dusty areas.

Frequent servicing of the air cleaner is especially important to help you avoid a possible costly engine repair.

If your motorcycle overturns or is involved in a crash, be sure your Honda dealer inspects all major parts, even if you are able to make some repairs.

## **⚠ WARNING**

Improperly maintaining this motorcycle or failing to correct a problem before you ride can cause a crash in which you can be seriously hurt or killed.

Always follow the inspection and maintenance recommendations and schedules in this owner's manual.

(cont'd)

# The Importance of Maintenance

---

Remember, proper maintenance is the owner's responsibility. Be sure to inspect your motorcycle before each ride and follow the Maintenance Schedule in this section.

## *Note to Parents:*

*As a parent, it's up to you to make sure that this motorcycle is properly maintained and kept in safe operating condition. For youngsters, learning how to take care of a motorcycle and perform basic maintenance can be an important part of their riding experience. However, if you allow a youngster to perform or assist in any maintenance task, such as filling the tank with gasoline, you should provide close supervision to make sure that it is performed safely.*

The maintenance section includes instructions on how to perform some important maintenance tasks. Some of the most important safety precautions follow. However, we cannot warn you of every conceivable hazard that can arise in performing maintenance. Only you can decide whether or not you should perform a given task.

## **WARNING**

Failure to properly follow maintenance instructions and precautions can cause you to be seriously hurt or killed.

Always follow the procedures and precautions in this owner's manual.

## **Important Safety Precautions**

- **Make sure the engine is off before you begin any maintenance or repairs.** This will help eliminate several potential hazards:

**Carbon monoxide poisoning from engine exhaust.** Be sure there is adequate ventilation whenever you operate the engine.

**Burns from hot motorcycle parts.** Let the engine and exhaust system cool before touching.

**Injury from moving parts.** Do not run the engine unless instructed to do so.

(cont'd)

# Maintenance Safety

---

- Read the instructions before you begin, and make sure you have the tools and skills required.
- To help prevent the motorcycle from falling over, park it on a firm, level surface, using the side stand or a maintenance stand to provide support.
- To reduce the possibility of a fire or explosion, be careful when working around gasoline. Use only a non-flammable (high flash point) solvent such as kerosene — not gasoline — to clean parts. Keep cigarettes, sparks, and flames away from all fuel-related parts.

# Maintenance Schedule

---

To maintain the safety and reliability of your motorcycle, regular inspection and service is required as shown in the Maintenance Schedule that follows.

The Maintenance Schedule lists items that can be performed with basic mechanical skills and hand tools. Procedures for these items are provided in this manual.

The Maintenance Schedule also includes items that involve more extensive procedures and may require special training, tools, and equipment. Therefore, we recommend that you have your Honda dealer perform these tasks unless you have advanced mechanical skills and the required tools. Procedures for items in this schedule are provided in a service manual available for purchase from your dealer (page 144).

Because your motorcycle does not have an odometer, service intervals in the maintenance schedules are expressed in terms of riding days as well as miles. To avoid overlooking required service, we urge you to develop a convenient way to record the number of days and/or miles you ride.

If you do not feel capable of performing a given task or need assistance, remember that your Honda dealer knows your motorcycle best and is fully equipped to maintain and repair it. If you decide to do your own maintenance, use only genuine Honda parts or their equivalents for repair or replacement to ensure the best quality and reliability.

(cont'd)

# Maintenance Schedule

---

Perform the pre-ride inspection (page 27 ) at each scheduled maintenance period.

Each item on the maintenance schedule requires some mechanical knowledge. Certain items (particularly those marked \* and \*\*) may require more technical information and tools. Consult your Honda dealer.

- \* Should be serviced by your Honda dealer, unless the owner has the proper tools and service data and is mechanically qualified. Refer to the official Honda Service Manual (page 144 ).
- \*\* In the interest of safety, we recommend these items be serviced only by your Honda dealer.

## *Summary of Maintenance Schedule Notes and Procedures:*

### NOTE:

1. Service more frequently when ridden in wet or dusty conditions.

### Maintenance Procedures:

- I: inspect and clean, adjust, lubricate, or replace, if necessary
- C: clean
- A: adjust
- L: lubricate
- R: replace

# Maintenance Schedule

Items	Frequency	Whichever Comes First ⇒	Initial Maint.	Regular Maint. Interval				Refer to page:
			mi	600	1,200	1,800	2,400	
		Note	Month	150	1,000	2,000	3,000	
* Fuel Line					I		I	—
** Fuel Strainer Screen					C		C	—
* Throttle Operation					I		I	69
Air Cleaner		Note 1		C	C	C	C	66
Spark Plug				I	I	I	I	76
* Valve Clearance			I	I	I	I	I	—
Engine Oil			R	R	R	R	R	60
** Engine Oil Strainer Screen					C		C	—
* Cam Chain Tension			A	A	A	A	A	—
** Engine Idle Speed			I	I	I	I	I	75

- \* Should be serviced by your Honda dealer, unless the owner has the proper tools and service data and is mechanically qualified. Refer to the official Honda Service Manual (page 144).
- \*\* In the interest of safety, we recommend these items be serviced only by your Honda dealer.

# Maintenance Schedule

Items	Frequency	Whichever Comes First ⇔	Initial Maint.	Regular Maint. Interval				Refer to page:		
				mi	100	600	1,200		1,800	2,400
				km	150	1,000	2,000		3,000	4,000
Note	Month	I	6	12	18	24				
Drive Chain		Note 1	I, L	I, L: every 300 mi (500 km) or 3 months				99		
Drive Chain Slider				I	I	I	I	100		
Brake Shoe Wear				I	I	I	I	86		
Brake System			I	I	I	I	I	83		
Clutch System			I	I	I	I	I	71		
Side Stand					I		I	98		
* Suspension					I		I	80		
* Spark Arrester				C: every 1,000 mi (1,600 km) or every 100 operating hours				78		
* Nuts, Bolts, Fasteners			I		I		I	—		
** Wheels/Tires			I	I	I	I	I	89, 94		
** Steering Head Bearings			I		I		I	—		

- \* Should be serviced by your Honda dealer, unless the owner has the proper tools and service data and is mechanically qualified. Refer to the official Honda Service Manual (page 144 ).
- \*\* In the interest of safety, we recommend these items be serviced only by your Honda dealer.

# Maintenance Record

Keeping an accurate maintenance record will help ensure that your motorcycle is properly maintained. Use the space under Notes to record anything you want to remind yourself about or mention to your dealer. Of course, if you find any problem while servicing your motorcycle, be sure it is corrected as soon as possible.

Miles or Months (km)	Date	Performed By:	Notes
600 (1,000) or 6			
1,200 (2,000) or 12			
1,800 (3,000) or 18			
2,400 (4,000) or 24			
3,000 (5,000) or 30			
3,600 (6,000) or 36			
4,200 (7,000) or 42			
4,800 (8,000) or 48			
5,400 (9,000) or 54			

# Maintenance Component Locations

---

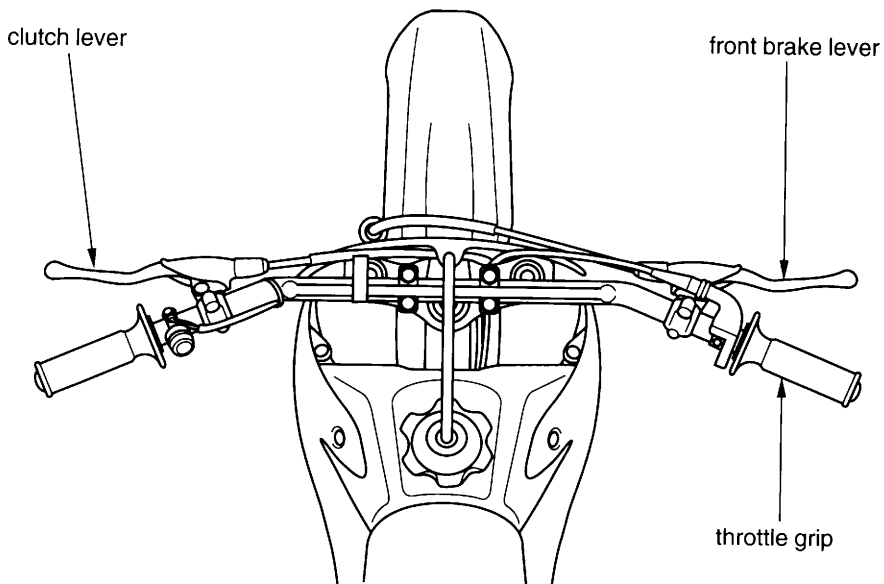

# Maintenance Component Locations

---

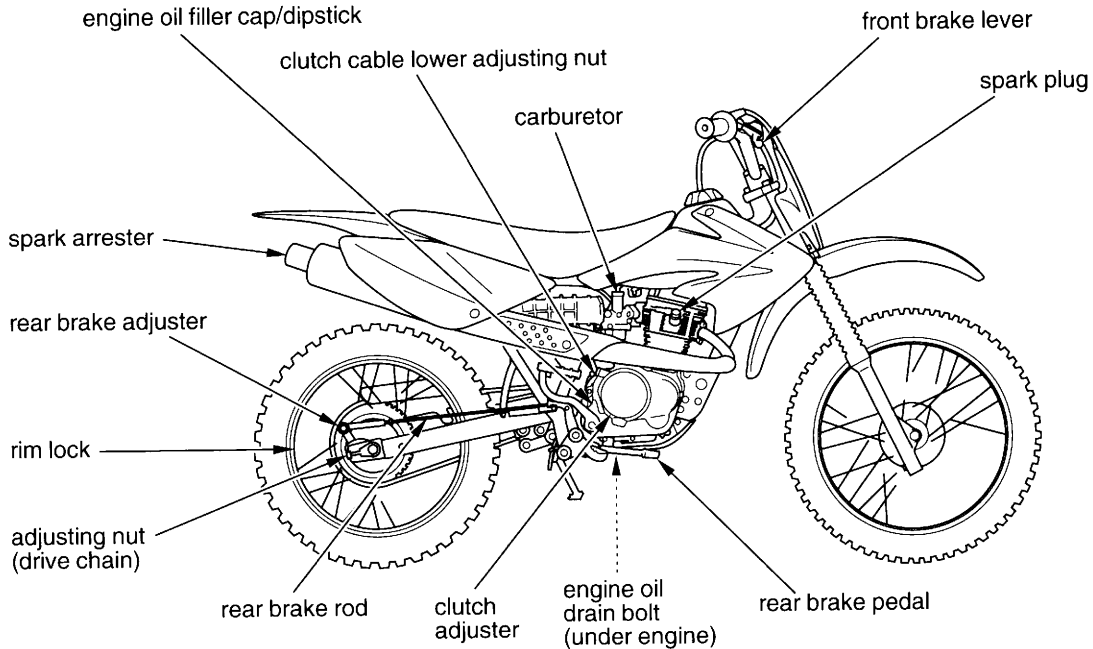

# Maintenance Component Locations

---

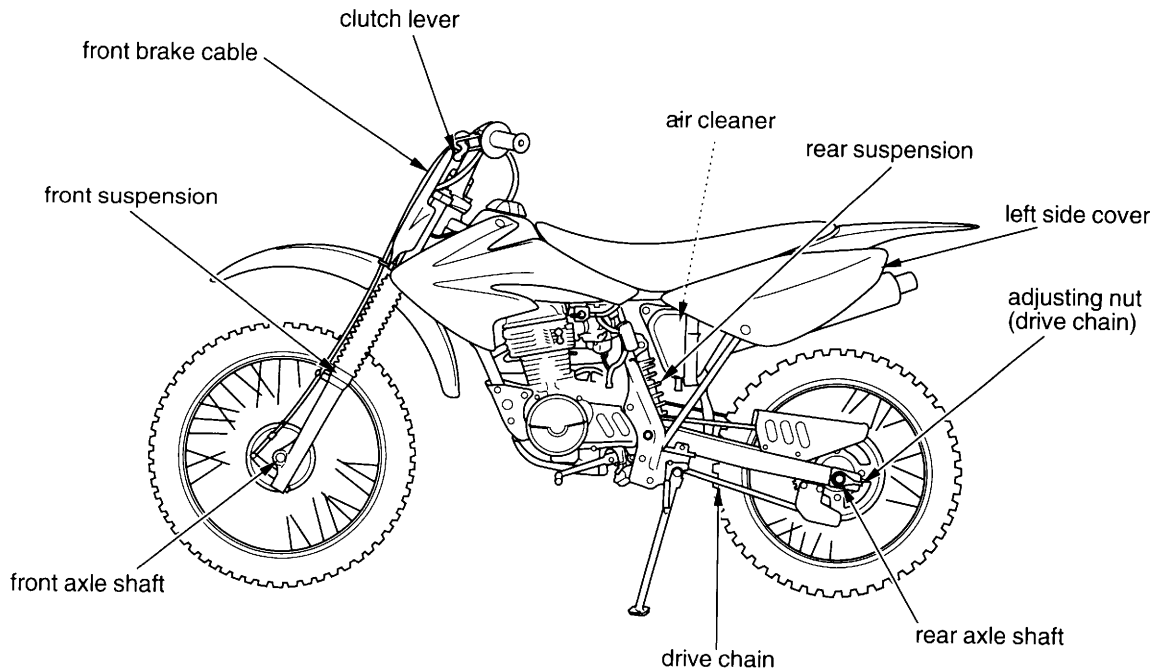

Refer to *Safety Precautions* on page 45.

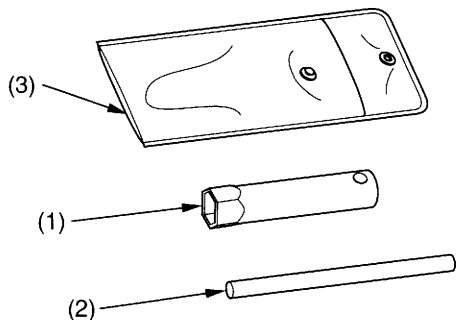

- (1) spark plug wrench
- (2) handle
- (3) tool bag

The spark plug wrench (1) and its handle (2) are stored in the tool bag (3) delivered with your motorcycle.

You will need to provide your own tools to perform any owner maintenance other than removing the spark plug.

# Side Cover Removal

Refer to *Safety Precautions* on page 45 .

LEFT SIDE

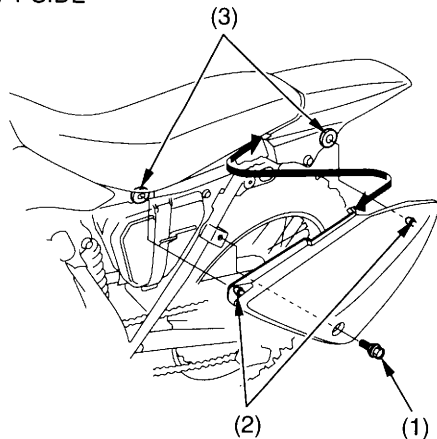

- (1) bolt
- (2) prongs
- (3) rubber grommets

## Removal

1. Remove the bolt ( 1 ) securing the side cover.
2. Pull both side cover prongs ( 2 ) out of the rubber grommets ( 3 ).

## Installation

1. Slide the top of the side cover under the bottom edge of the seat.
2. Align the side cover prongs with the rubber grommets. Press the side cover into position.
3. Install the securing bolt and tighten it.

Refer to *Safety Precautions* on page 45.

## Fuel Recommendation

Type	unleaded
Pump Octane Number	86 (or higher)

Your engine is designed to use any gasoline that has a pump octane number of 86 or higher. Gasoline pumps at service stations normally display the pump octane number. For information on the use of oxygenated fuels, see page 141.

Use of lower octane gasoline can cause persistent “pinging” or “spark knock” (a louder rapping noise) which, if severe, can lead to engine damage. (Light pinging experienced while operating under a heavy load, such as climbing a hill, is no cause for concern.)

If pinging or spark knock occurs at a steady engine speed under normal load, change brands of gasoline. If pinging or spark knock persists, consult your Honda dealer.

We recommend that you use unleaded fuel because it produces fewer engine deposits and extends the life of exhaust system components.

Never use stale or contaminated gasoline or an oil/gasoline mixture. Avoid getting dirt, dust, or water in the fuel tank.

# Fuel

## Refueling Procedure

Fuel Tank Capacity, including reserve:  
1.45 US gal (5.5 ℓ)

Reserve Capacity:  
0.29 US gal (1.1 ℓ)

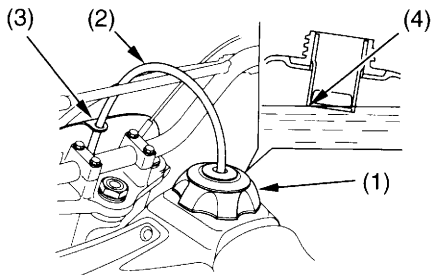

(1) fuel fill cap  
(2) breather tube

(3) front number plate  
(4) filler neck

1. To open the fuel fill cap (1), pull the breather tube (2) away from the front number plate (3). Turn the fuel fill cap counterclockwise and remove it.
2. Add fuel until the level reaches the bottom of the filler neck (4). Avoid overfilling the tank. There should be no fuel in the filler neck.

## **⚠ WARNING**

Gasoline is highly flammable and explosive. You can be burned or seriously injured when handling fuel.

- Stop the engine and keep heat, sparks and flame away.
- Handle fuel only outdoors.
- Wipe up spills immediately.

3. After refueling, turn the fuel fill cap clockwise until it is secure.
4. Check that the breather tube is properly seated in the front number plate.

If you replace the fuel fill cap, use only a genuine Honda replacement part.

# Engine Oil

---

Refer to *Safety Precautions* on page 45.

Using the proper oil, and regularly checking, adding, and changing oil will help extend your engine's life. Even the best oil wears out. Changing oil helps get rid of dirt and deposits held in the engine. Operating the engine with old or dirty oil can damage your engine. Running the engine with insufficient oil can cause serious damage to the engine and transmission.

## Oil Recommendation

API classification	SG or higher except oils labeled as energy conserving on the circular API service label
viscosity (weight)	SAE 10W-40*
JASO T 903 standard	MA
suggested oil**	Pro Honda GN4 or HP4 (without molybdenum additives) 4-stroke oil (USA & Canada), or Honda 4-stroke oil (Canada only), or an equivalent motorcycle oil

- \* For normal air temperatures. See next page for additional temperature/viscosity information.
- \*\* Suggested oils are equal in performance to SJ oils that are not labeled as energy conserving on the circular API service label.

- Your motorcycle does not need oil additives. Use the recommended oil.
- Do not use oils with graphite or molybdenum additives. They may adversely affect clutch operation.
- Do not use API SH or higher oils displaying a circular API “energy conserving” service label on the container. They may affect lubrication and clutch performance.

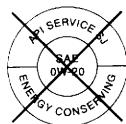

NOT RECOMMENDED



OK

- Do not use non-detergent, vegetable, or castor based racing oils.

(cont'd)

# Engine Oil

Other viscosities shown in the following chart may be used when the average temperature in your riding area is within the indicated range.

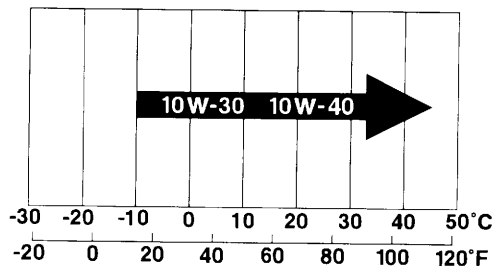

## JASO T 903 standard

The JASO T 903 standard is an index for engine oils for 4-stroke motorcycle engines. There are two classes: MA and MB. Oil conforming to the standard is labeled on the oil container. For example, the following label shows the MA classification.

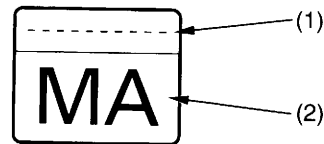

PRODUCT MEETING JASO T 903  
COMPANY GUARANTEEING THIS MA PERFORMANCE:

- (1) code number of the sales company of the oil
- (2) oil classification

## Checking & Adding Oil

RIGHT SIDE

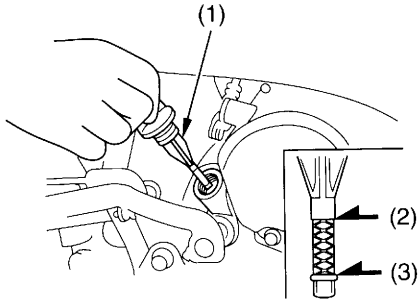

- (1) oil filler cap/dipstick
- (2) upper level mark
- (3) lower level mark

1. Park your motorcycle on a firm, level surface.
2. Clean around the oil filler cap/dipstick ( 1 ) and nearby surfaces.

3. Start the engine and let it idle for 3—5 minutes. Stop the engine. Wait 2—3 minutes.
4. Immediately unscrew and remove the oil filler cap/dipstick. Wipe it clean.
5. Hold the motorcycle upright.
6. Insert the oil filler cap/dipstick until it seats, but do not screw it in.
7. Remove the oil filler cap/dipstick and check the oil level.
  - If the oil is at or near the upper level mark ( 2 ), you do not have to add oil.
  - If the oil is below or near the lower level mark ( 3 ), add the recommended oil until it reaches the upper level mark. (Do not overfill.)
8. Insert the oil filler cap/dipstick and screw it in tightly.
9. Check for oil leaks.

# Engine Oil

## Changing Engine Oil

UNDER

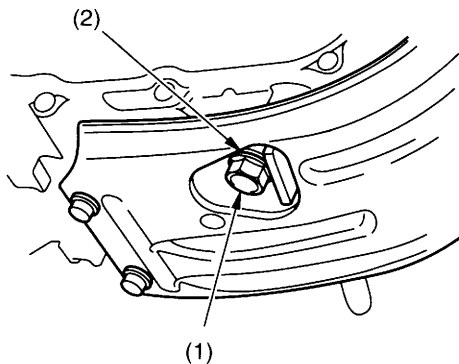

- (1) oil drain bolt  
(2) sealing washer

1. If the engine is cold, start it and let it idle for 3-5 minutes. Turn the engine off. Wait 2-3 minutes for the oil to settle.
2. Park your motorcycle on a firm, level surface.
3. Remove the oil filler cap/dipstick.
4. Place a drain pan under the crankcase.
5. Unscrew and remove the oil drain bolt (1).
6. After most of the oil is drained, gently tilt the motorcycle from side to side to drain the remaining oil.
7. Pour the drained oil into a suitable container and dispose of it in an approved manner (page 117).

### NOTICE

*Improper disposal of drained fluids is harmful to the environment.*

8. Remove the old sealing washer (2) and install a new sealing washer on the drain bolt.
9. Install the oil drain bolt and tighten to the specified torque:  
18 lbf·ft (24 N·m , 2.5 kgf·m)
10. Pour the recommended oil into the crankcase, approximately:  
1.0 US qt (0.9 ℓ)
11. Install the oil filler cap/dipstick securely.
12. Start the engine. Let it idle 3-5 minutes, then turn it off.
13. With the motorcycle held upright on level ground, check the oil level.  
If needed, add oil (page 63 ) until it reaches the upper level mark. (Do not overfill.)
14. Check for oil leaks.

# Air Cleaner

---

Refer to *Safety Precautions* on page 45 .

Proper air cleaner maintenance is very important for off-road vehicles. A dirty, water-soaked, worn-out, or defective air cleaner will allow dirt, dust, mud, and other impurities to pass into the engine.

Service the air cleaner more frequently if you ride in unusually wet or dusty areas. Your Honda dealer can help you determine the correct service interval for your riding conditions.

Your motorcycle's air cleaner has very specific performance requirements. Use a new genuine Honda air cleaner specified for your model or an air cleaner of equal quality.

## NOTICE

*Using the wrong air cleaner can result in premature engine damage.*

Proper air cleaner maintenance can prevent premature engine wear or damage, expensive repairs, low engine power, poor gas mileage, and spark plug fouling.

## NOTICE

*Improper or lack of proper air cleaner maintenance can cause poor performance and premature engine wear.*