

 **HONDA**

OWNER'S MANUAL

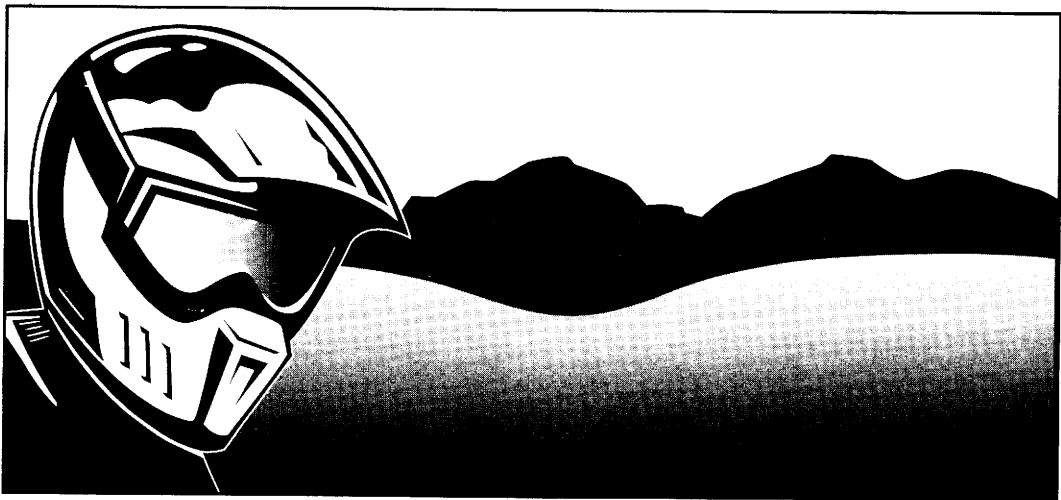

2004

CT110

Honda CT110

OWNER'S MANUAL

IMPORTANT NOTICE

- **OPERATOR ONLY. NO PASSENGER**

This motorcycle is designed and constructed as an operator-only model. The seating configuration does not safely permit the carrying of a passenger. Do not exceed the maximum weight capacity.

- **ON/OFF-ROAD USE**

This motorcycle is designed for “dual purpose” use.

- **READ THIS OWNER’S MANUAL CAREFULLY**

Pay special attention to statements preceded by the following words:

▲ WARNING

Indicates a strong possibility of severe personal injury or death if instructions are not followed.

CAUTION:

Indicates a possibility of personal injury or equipment damage if instructions are not followed.

NOTE: Gives helpful information.

This manual should be considered a permanent part of the motorcycle and should remain with the motorcycle when resold.

Honda CT110 OWNER'S MANUAL

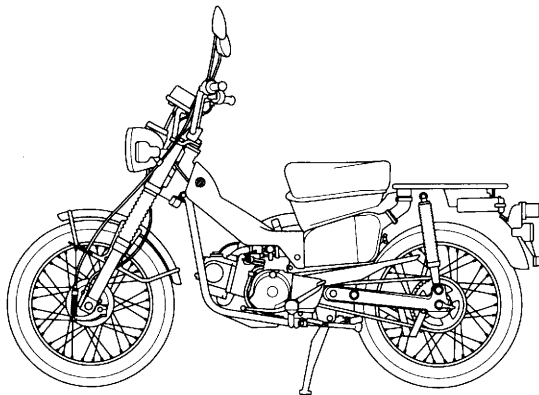

All information in this publication is based on the latest production information available at the time of approval for printing. Honda Motor Co.,Ltd. reserves the right to make changes at any time without notice and without incurring any obligation.

No part of this publication may be reproduced without written permission.

WELCOME

The motorcycle presents you a challenge to master the machine, a challenge to adventure. You ride through the wind, linked to the road by a vehicle that responds to your commands as no other does. Unlike an automobile, there is no metal cage around you. Like an airplane, a pre-ride inspection and regular maintenance are essential to your safety. Your reward is freedom.

To meet the challenges safely, and to enjoy the adventure fully, you should become thoroughly familiar with this owner's manual **BEFORE YOU RIDE THE MOTORCYCLE**.

When service is required, remember that your Honda dealer knows your motorcycle best. If you have the required mechanical "know-how" and tools, your dealer can supply you with an official Honda Service Manual to help you perform many maintenance and repair tasks.

Pleasant riding, and thank you for choosing a Honda !

- The illustrations herein are based on the UY type.
- Following codes in this manual indicate each country.

UY	Australian Postal ministry
UB	Australian Agric
NZ	New – Zealand

- The specifications may vary with each locale.

OPERATION

page		page	
1	MOTORCYCLE SAFETY	24	Left Handlebar Controls
1	Safe Riding Rules	25	Parking Brake
2	Protective Apparel		
3	Modifications	26	FEATURES
4	Loading and Accessories		(Not required for operation)
		26	Steering Lock
6	PARTS LOCATION	27	Helmet Holder
9	Instruments and Indicators	28	Headlight Aim Vertical Adjustment
		29	Right Side Cover
11	MAJOR COMPONENTS		
	(Information you need to operate this motorcycle)	30	OPERATION
11	Brakes	30	Pre-ride Inspection
14	Rear Suspension	31	Starting the Engine
15	Clutch	33	Running-in
16	Fuel	34	Riding
20	Engine Oil	36	Braking
21	Tyres	37	Parking
		37	Anti-theft Tips
22	ESSENTIAL INDIVIDUAL COMPONENTS		
22	Ignition Switch		
23	Right Handlebar Controls		

MAINTENANCE

page

38	MAINTENANCE
39	Maintenance Schedule
42	Tool Kit
44	Serial Numbers
45	Maintenance Precautions
46	Air Cleaner
48	Engine Oil
51	Spark Plug
53	Valve Clearance
55	Throttle Operation
56	Idle Speed
57	Cam Chain Adjustment
58	Drive Chain
62	Front and Rear Suspension Inspection
63	Side Stand
64	Wheel Removal
68	Brake Shoe Wear
69	Battery
73	Fuse Replacement
75	Stoplight Switch Adjustment

page

76	CLEANING
77	STORAGE GUIDE
77	Storage
79	Removal from Storage
80	SPECIFICATIONS
84	NOISE CONTROL SYSTEM (AUSTRALIA ONLY)

MOTORCYCLE SAFETY

▲WARNING

*** Motorcycle riding requires special efforts on your part to ensure your safety. Know these requirements before you ride:**

SAFE RIDING RULES

1. Always make a pre-ride inspection (page 30) before you start the engine. You may prevent an accident or equipment damage.
2. Many accidents involve inexperienced riders. Most countries require a special motorcycle riding test or license. Make sure you are qualified before you ride. NEVER lend your motorcycle to an inexperienced rider.
3. Many automobile/motorcycle accidents happen because the automobile driver does not “see” the motorcyclist. Make yourself conspicuous to help avoid the accident that wasn’t your fault:
 - Wear bright or reflective clothing.
 - Don’t ride in another motorist’s “blind spot.”
4. Obey all national and local laws and regulations.
 - Excessive speed is a factor in many accidents. Obey the speed limits, and NEVER travel faster than conditions warrant.
 - Signal before you make a turn or lane change. Your size and maneuverability can surprise other motorists.

5. Don't let other motorists surprise you. Use extra caution at intersections, parking lot entrances and exits, and driveways.
6. Keep both hands on the handlebars and both feet on the footpegs while riding.

PROTECTIVE APPAREL

1. Most motorcycle accident fatalities are due to head injuries: **ALWAYS** wear a helmet. You should also wear a face shield or goggles as well as boots, gloves, and protective clothing.
2. The exhaust system becomes hot during operation, and it remains hot for a while after stopping the engine. Be careful not to touch the exhaust system while it is hot. Wear clothing that fully covers your legs.
3. Do not wear loose clothing which could catch on the control levers, kickstarter, footpegs, drive chain or wheels.

MODIFICATIONS

▲WARNING

- * Modification of the motorcycle, or removal of original equipment, may render the vehicle unsafe or illegal. Obey all national and local equipment regulations.**

LOADING AND ACCESSORIES

▲WARNING

*** A motorcycle is sensitive to changes in weight distribution. Addition of accessories or cargo can impair the motorcycle's stability and performance. To prevent an accident, use extreme care when adding and riding with cargo and accessories. These general guidelines may help you decide whether, or how to equip your motorcycle.**

Loading

The combined weight of the rider, cargo, and all accessories must not exceed the maximum weight capacity:

109 kg (240 lbs)

1. Keep cargo and accessory weight low and close to the center of the motorcycle. Load weight equally on both sides to minimize imbalance. As weight is located further from the motorcycle's center of gravity, handling is proportionally affected.
2. All cargo and accessories must be secure for stable handling. Recheck cargo security and accessory mounts frequently.
3. Do not attach large or heavy items (such as a sleeping bag or tent) to the handlebars, fork, or fender. Unstable handling or slow steering response may result.

Accessories

Genuine Honda accessories have been specifically designed for and tested on this motorcycle. Because the factory cannot test all other accessories, you are personally responsible for proper selection, installation, and use of non-Honda accessories. Always follow the guidelines under Loading, and these:

1. Carefully inspect the accessory to make sure it does not reduce ground clearance, or limit suspension travel, steering travel or control operation.
2. Luggage racks are for lightweight items. Bulky items may snag on a tree or other nearby object causing loss of control.
3. Do not add electrical equipment that will exceed the motorcycle's electrical system capacity. An electrical failure could cause a dangerous loss of lights or engine power at night, far from help.

PARTS LOCATION

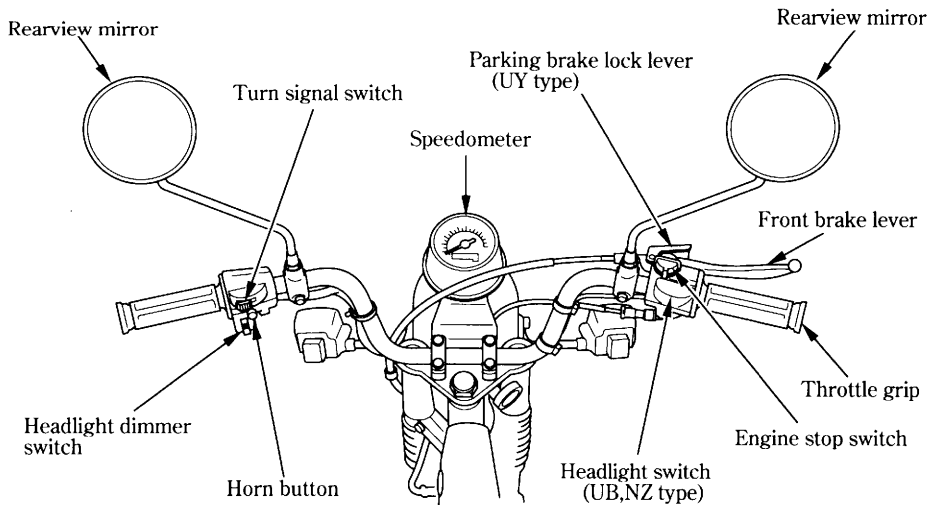

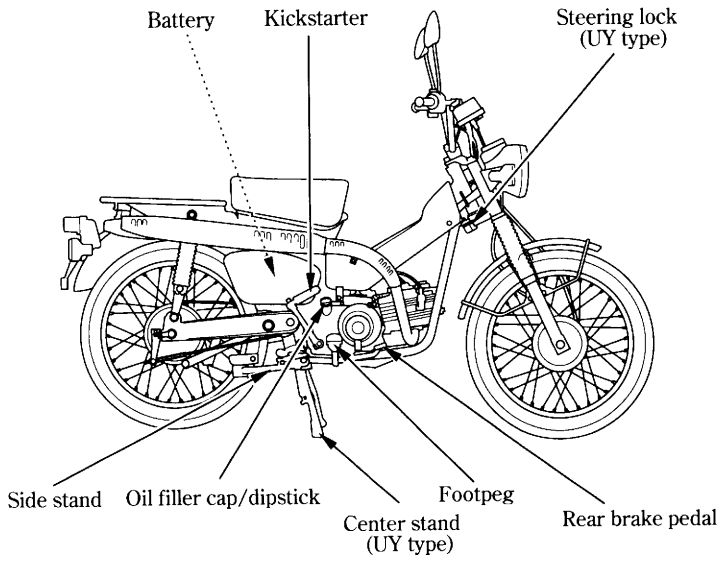

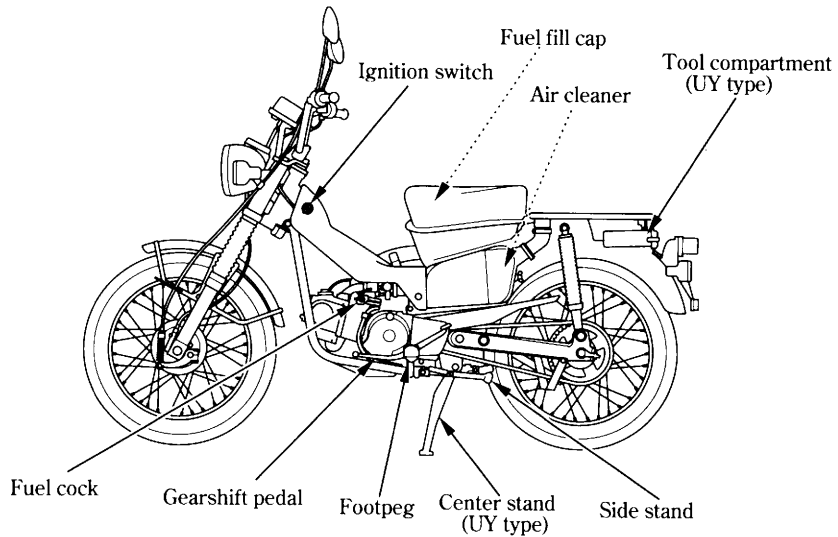

INSTRUMENTS AND INDICATORS

The indicators are grouped above the headlight case.

Their functions are described in the table on the following page.

- (1) Speedometer
- (2) Neutral indicator
- (3) Turn signal indicator
- (4) Gear/speed range indicators
- (5) Odometer
- (6) High beam indicator

(UY type)

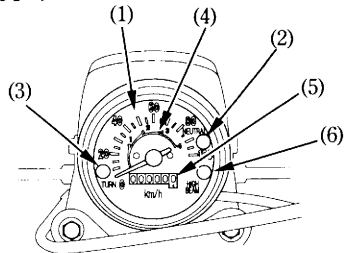

(UB,NZ type)

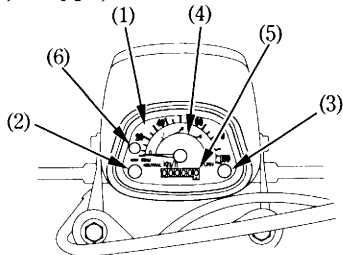

(Ref. No.) Description	Function
(1) Speedometer	Shows riding speed.
(2) Neutral indicator (green)	Lights when the transmission is in neutral.
(3) Turn signal indicator (amber)	Flashes when either turn signal is operated.
(4) Gear/speed range indicators	Shows proper speed range for each gear.
(5) Odometer	Shows accumulated mileage.
(6) High beam indicator (blue)	Lights when the headlight is on high beam.

MAJOR COMPONENTS (Information you need to operate this motorcycle)

▲WARNING

*** If the Pre-ride Inspection (page 30) is not performed, severe personal injury or vehicle damage may result.**

BRAKES

Front Brake

Brakes are items of personal safety and should always be maintained in proper adjustment.

The distance the front brake lever moves before the brake starts to engage is called free play.

Measured at the tip of the front brake lever, free play should be maintained at:

(UY type)

10–20 mm (0.4–0.8 in)

(UB, NZ type)

20–30 mm (0.8–1.2 in)

Adjustment:

1. Loosen the lock nut (1) and turn the adjuster (2). Tighten the lock nut (1) and check the adjustment.
2. If the adjuster is threaded out near its limit or if the correct free play cannot be obtained, loosen the lock nut (1) and turn in the cable adjuster (2) completely. Tighten the lock nut (1).

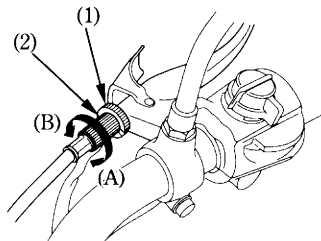

- | | |
|--------------------------|------------------------|
| (1) Lock nut | (A) Increase free play |
| (2) Brake cable adjuster | (B) Decrease free play |

3. At the lower end of the cable, loosen the lock nut (4). Turn the adjusting nut (3) to obtain the specified free play. Tighten the lock nut (4) and check the adjustment.

NOTE:

- * If proper adjustment cannot be obtained by this method see your Honda dealer.

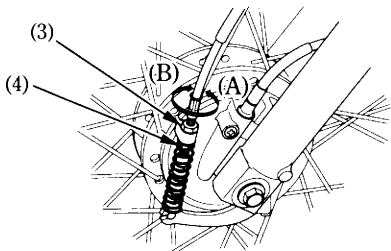

- (3) Front brake adjusting nut
- (4) Lock nut
- (A) Increase free play
- (B) Decrease free play

Other Checks:

Check the brake cable for kinks or signs of wear that could cause sticking or failure. Lubricate the brake cable with a commercially available cable lubricant to prevent premature wear and corrosion. Make sure the brake arm, spring and fasteners are in good condition.

Rear Brake

Adjustment:

1. (UY type)

Place the motorcycle on its center stand.

(UB, NZ type)

Place the motorcycle on its side stand.

2. Measure the distance the rear brake pedal (1) moves before the brake starts to take hold.

Free play should be:

20 – 30 mm (0.8 – 1.2 in)

3. If adjustment is necessary, turn the rear brake adjusting nut (2).

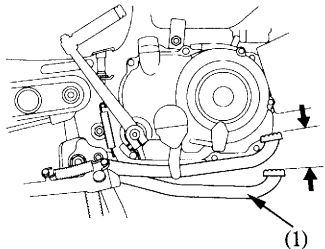

(1) Rear brake pedal

4. Apply each brake several times and check for free wheel rotation when released.

Other Checks:

Make sure the brake arm, brake rod, spring and fasteners are in good condition.

NOTE:

- * If proper adjustment cannot be obtained by this method see your Honda dealer.
- * Make sure the cut-out on the adjusting nut is seated on the brake arm pin (3) after making final free play adjustment.

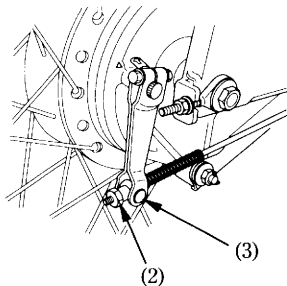

(2) Rear brake adjusting nut

(3) Brake arm pin

SUSPENSION

Each shock absorber (1) has 5 adjustment positions for different load or riding conditions.

Use the handle lever (2) to adjust the rear shocks.

Position 1 is for light loads and smooth road conditions. Positions 2 to 5 increase spring preload for a stiffer rear suspension, and can be used when the motorcycle is heavily loaded. Be certain to adjust both shock absorbers to the same position.

Standard position : 1 (UB, NZ type)

Standard position : 2 (UY type)

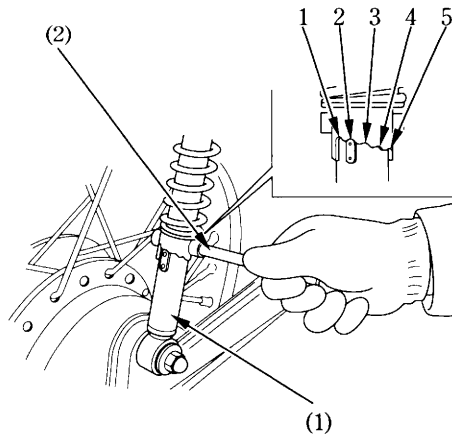

(1) Shock absorber

(2) Handle lever

CLUTCH

Adjustment:

1. The clutch is adjusted with the engine off.
Remove the cover protector (1) and loosen the adjuster lock nut (2).
2. Turn the clutch adjuster (3) clockwise one turn; do not turn excessively.
3. Slowly turn the adjuster counterclockwise until a slight resistance is felt.
4. From this position, turn the adjuster clockwise 1/8 turn, and tighten the lock nut.
5. After adjustment, test ride the motorcycle to be certain the clutch operates properly.

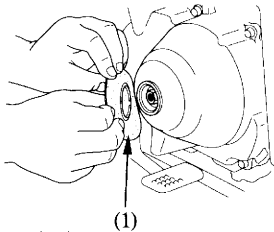

(1) Cover protector

The engine should start easily with the kickstarter without the clutch slipping. When shifting gears, the clutch operation should be smooth and light, especially when shifting into neutral.

NOTE:

- * If proper adjustment cannot be obtained or the clutch does not work correctly, see your Honda dealer.

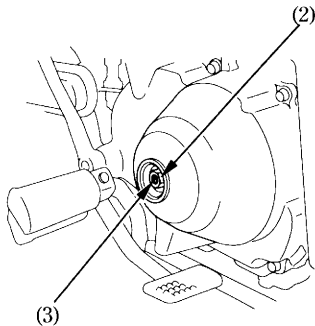

(2) Lock nut
(3) Clutch adjuster

FUEL

Fuel Cock

The three way fuel cock (1) is on the left underneath the fuel tank.

OFF

With the fuel cock in the OFF position, fuel cannot flow from the tank to the carburetor. Turn the cock OFF whenever the motorcycle is not in use.

ON

With the fuel cock in the ON position, fuel will flow from the main fuel supply to the carburetor.

RES

With the fuel cock in the RES position, fuel will flow from the reserve fuel supply to the carburetor. Use the reserve fuel only when the main supply is gone. Refill the tank as soon as possible after switching to RES.

The reserve fuel supply is:

0.9 ℓ (0.24 US gal , 0.20 Imp gal)

▲WARNING

- * To avoid running out of fuel that may result in a sudden stop, learn how to operate the fuel cock when riding the motorcycle.
- * Be careful not to touch any hot engine parts while operating the fuel cock.

NOTE:

- * Remember to check that the fuel cock is in the ON position each time you refuel. If the cock is left in the RES position, you may run out of fuel with no reserve.

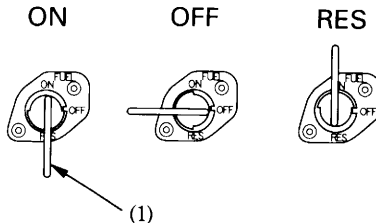

(1) Fuel cock

Fuel Tank

The fuel tank is located under the seat. To raise the seat, then remove the fuel fill cap (1) by turning it counterclockwise.

The fuel tank capacity including the reserve supply is:

4.8 ℓ (1.27 US gal, 1.06 Imp gal)

After refueling, be sure to tighten the fuel fill cap firmly by turning it clockwise.

Make sure that the allow marks (2) on the fuel fill cap and fuel tank is aligned.

Use unleaded or low-lead petrol with a research octane number of 91 or higher. We recommend that you use unleaded petrol because it produces fewer engine and spark plug deposits and extends the life of exhaust system components.

FOR AUSTRALIA ONLY:

Use unleaded petrol with a research octane number of 91 or higher.

CAUTION:

* If “spark knock” or “pinking” occurs at a steady engine speed under normal load, change brands of petrol. If spark knock or pinking persists, consult your Honda dealer. Failure to do so is considered misuse, and damage caused by misuse is not covered by Honda’s Limited Warranty.

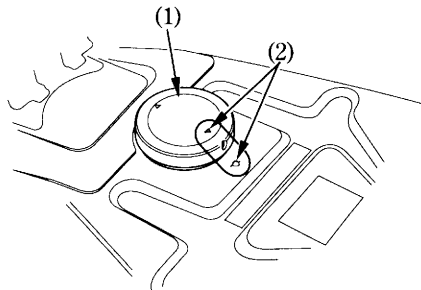

(1) Fuel fill cap

(2) Allow marks

▲WARNING

- * Petrol is extremely flammable and is explosive under certain conditions. Refuel in a well-ventilated area with the engine stopped. Do not smoke or allow flames or sparks in the area where petrol is stored or where the fuel tank is refueled.
- * Do not overfill the tank (there should be no fuel in the filler neck (3)). After refueling, make sure the fuel fill cap is closed securely.
- * Be careful not to spill fuel when refueling. Spilled fuel or fuel vapor may ignite. If any fuel is spilled, make sure the area is dry before starting the engine.
- * Avoid repeated or prolonged contact with skin or breathing of vapor. **KEEP OUT OF REACH OF CHILDREN.**

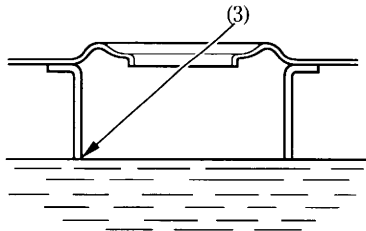

(3) Filler neck

Petrol Containing Alcohol

If you decide to use a petrol containing alcohol (gasohol), be sure it's octane rating is at least as high as that recommended by Honda. There are two types of "gasohol": one containing ethanol, and the other containing methanol. Do not use petrol that contains more than 10 % ethanol. Do not use petrol containing methanol (methyl or wood alcohol) that does not also contain cosolvents and corrosion inhibitors for methanol. Never use petrol containing more than 5 % methanol, even if it has cosolvents and corrosion inhibitors.

NOTE:

- * Fuel system damage or engine performance problems resulting from the use of fuels that contain alcohol is not covered under the warranty. Honda cannot endorse the use of fuels containing methanol since evidence of their suitability is as yet incomplete.
- * Before buying fuel from an unfamiliar station, try to find out if the fuel contains alcohol. If it does, confirm the type and percentage of alcohol used. If you notice any undesirable operating symptoms while using a petrol that contains alcohol, or one that you think contains alcohol, switch to a petrol that you know does not contain alcohol.

ENGINE OIL

Engine Oil Level Check

Check the engine oil level each day before riding the motorcycle.

The level must be maintained between the upper (1) and lower (2) level marks on the dipstick (3).

1. Start the engine and let it idle for a few minutes.

2. (UY type)

Stop the engine and put the motorcycle on its center stand on level ground.

(UB, NZ type)

Stop the engine and hold the motorcycle in an upright position on firm, level ground.

3. After a few minutes, remove the oil filler cap/dipstick (3), wipe it clean, and reinsert the dipstick without screwing it in. Remove the dipstick. The oil level should be between the upper (1) and lower (2) level marks on the dipstick.

4. If required, add the specified oil (see page 48) up to the upper level mark. Do not overfill.

5. Reinstall the oil filler cap/dipstick. Check for oil leaks.

CAUTION:

*** Running the engine with insufficient oil pressure may cause serious engine damage.**

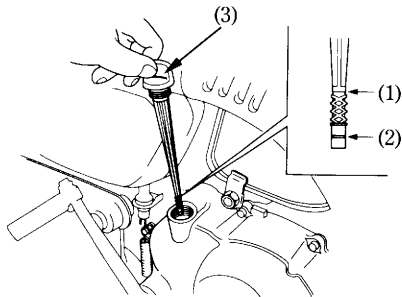

- (1) Upper level mark (3) Oil filler cap/dipstick
(2) Lower level mark

TYRES

Proper air pressure will provide maximum stability, riding comfort and tyre life.

Check tyre pressure frequently and adjust if necessary.

NOTE:

- * Tyre pressure should be checked before you ride while the tyres are “cold”.
- * (UY type)

This motorcycle is fitted with TUFFUP tubes in both the front and rear wheels. Compared with ordinary tyre tubes, the TUFFUP tube releases little air when punctured by a nail or other similar object. For this reason, even though they remain fully inflated, it is important to regularly check the tyres for embedded objects. When replacing a TUFFUP tube, be sure to select the size appropriate for the tyre. Because of the special construction of the TUFFUP tube, it should always be repaired or replaced by your Honda dealer.

On/off-road tyres are standard on this model. Select the right replacement tyres in accordance with the following specifications. Check the tyres for cuts, embedded nails, or other sharp objects. See your Honda dealer for replacement of damaged tyres or punctured inner tubes.

	Front	Rear
Tyre size	2.75 – 17 41P	2.75 – 17 41P
Cold tyre pressures kPa (kgf/cm ² , psi)	175 (1.75 , 25)	225 (2.25 , 33)

ESSENTIAL INDIVIDUAL COMPONENTS

IGNITION SWITCH

The ignition switch (1) is on the left side of the steeringhead pipe.

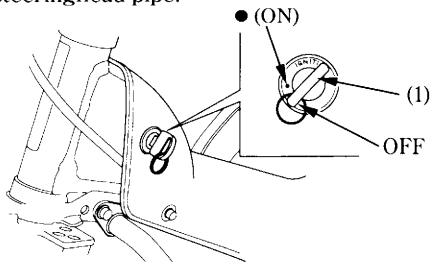

(1) Ignition switch

Key Position	Function	Key Removal
OFF	Engine and lights cannot be operated.	Key can be removed
● (ON)	Engine and lights can be operated.	Key cannot be removed

RIGHT HANDLEBAR CONTROLS

Engine Stop Switch

The engine stop switch (1) is next to the throttle grip. When the switch is in the RUN position, the engine will operate. When the switch is in the OFF position, the engine will not operate. This switch is intended primarily as a safety or emergency switch and should normally remain in the RUN position.

(UY type)

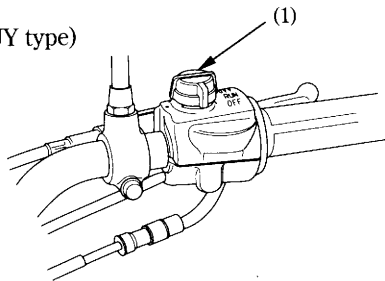

Headlight Switch (UB, NZ type)

The headlight switch (2) has three positions; "H", "P" and "OFF" marked by a dot to the right of "P".

H: Headlight, taillight, position light and meter lights on.

P: Position light, taillight and meter light on.

OFF(dot): Headlight, taillight, position light and meter lights off.

(UB,NZ type)

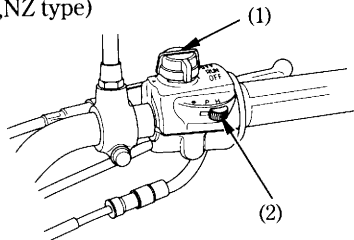

- (1) Engine stop switch
- (2) Headlight switch

LEFT HANDLEBAR CONTROLS

Headlight Dimmer Switch (1)

Move the headlight dimmer switch to “Hi” to select high beam or to “Lo” to select low beam.

Turn Signal Switch (2)

Move to L to signal a left turn, R to signal a right turn. Remember to return the switch to the center (off) after completing your turn or lane change.

Horn Button (3)

Press the button to sound the horn.

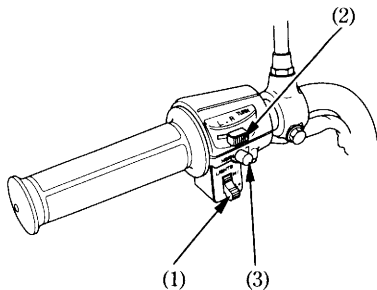

- (1) Headlight dimmer switch
- (2) Turn signal switch
- (3) Horn button

PARKING BRAKE (UY type)

The front brake lever has a lock which allows it to be used as a parking brake.

Always set the parking brake when parking and before starting the engine.

NOTE:

- * Using the parking brake in freezing weather may cause the brakes to freeze in the locked position.

To set the parking brake:

Squeeze the front brake lever (1) and lock it with the lock lever (2).

To unlock the parking brake:

Squeeze the front brake lever until the lock lever releases.

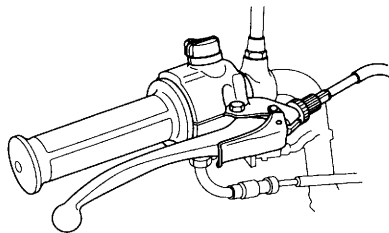
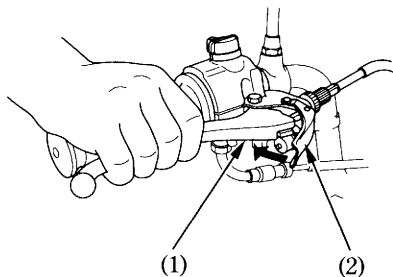

(1) Front brake lever (2) Lock lever

FEATURES

(Not required for operation)

STEERING LOCK (UY type)

The steering lock (1) is on the steering stem.

To Lock:

Turn the handlebar all the way to the left and insert the key into the lock, turn the key 180° clockwise and remove it.

To unlock the steering, perform the locking sequence in the reverse order.

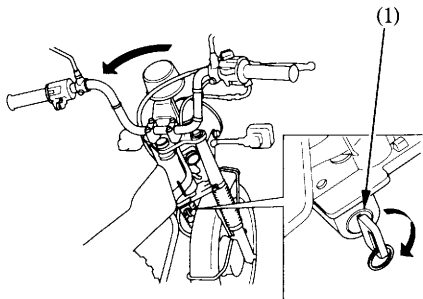

(1) Steering lock

HELMET HOLDER (UB,NZ type)

The helmet holder (1) is on the left side of the rear carrier. Insert the ignition key (2) and turn it counterclockwise to unlock. Hang your helmet on the holder pin (3) and push it in to lock. Remove the key.

▲WARNING

*The helmet holder is designed for helmet security while parked. Do not ride with a helmet attached to the holder; the helmet may interfere with safe operation and result in loss of control.

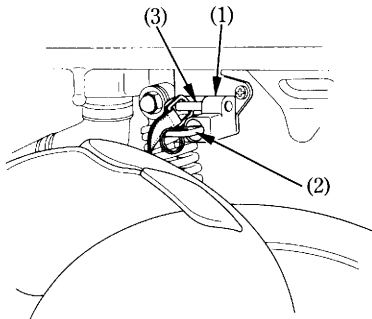

- (1) Helmet holder
- (2) Ignition key
- (3) Holder pin

HEADLIGHT AIM VERTICAL ADJUSTMENT

Vertical adjustment can be made by moving the headlight case (1) as necessary.

To move the headlight case (1), loosen the bolts (2).

Tighten the bolts (2) after adjustment.

Obey local laws and regulations.

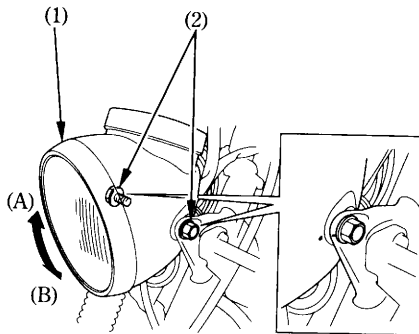

(1) Headlight case

(2) Bolts

(A) Up

(B) Down

RIGHT SIDE COVER

The right side cover must be removed for battery and fuse maintenance.

Right side cover removal:

1. Remove the screw (1).
2. Pull the top of the right side cover (2).
3. Remove the right side cover.

Right side cover installation:

- Install the removed parts in the reverse order of removal.

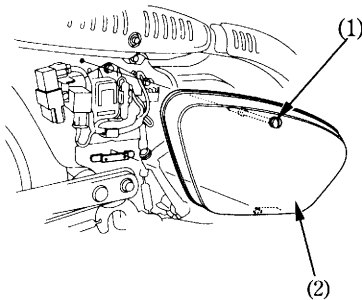

- (1) Screw
(2) Right side cover

OPERATION

PRE-RIDE INSPECTION

▲WARNING

*** If the Pre-ride Inspection is not performed, severe personal injury or vehicle damage may result.**

Inspect your motorcycle every day before you ride it. The items listed here will only take a few minutes to inspect, and in the long run they can save time, expense, and possibly your life.

1. Engine oil level—add engine oil if required (page 20). Check for leaks.
2. Fuel level—fill fuel tank when necessary (page 16–19). Check for leaks.
3. Front and rear brakes—check operation and if necessary, adjust free play (pages 11–13).

4. Tyres—check condition and pressure (page 21).
5. Drive chain—check condition and slack (page 58). Adjust and lubricate if necessary.
6. Throttle—check for smooth opening and full closing in all steering positions.
7. Lights and horn—check that headlight, tail/brake light, turn signals, indicators and horn function properly.
8. Engine stop switch—check for proper function (page 23).
9. (UB,NZ type)
Battery electrolyte—check the level and add if necessary (pages 71–72).

Correct any discrepancy before you ride. Contact your Honda dealer for assistance if you cannot correct the problem.

STARTING THE ENGINE

Always follow the proper starting procedure described below.

▲WARNING

- * **Never run the engine in an enclosed area. The exhaust contains poisonous carbon monoxide gas that can cause loss of consciousness and lead to death.**
- * **Attempting to start the engine with the transmission in gear and the clutch engaged may result in injury or damage.**

Preparation

Before starting, insert the key, turn the ignition switch ● (ON) and confirm the following:

- Lock the parking brake. (UY type)
- The transmission is in NEUTRAL (neutral indicator light ON).
- The engine stop switch is at RUN.
- The fuel cock is ON.
- Retract the right side stand.

Starting Procedure

To restart a warm engine, follow the procedure for “High Air Temperature.”

Normal Air Temperature

10° – 35° C (50° – 95° F)

1. Pull the choke lever (1) up all the way to Fully ON (A).

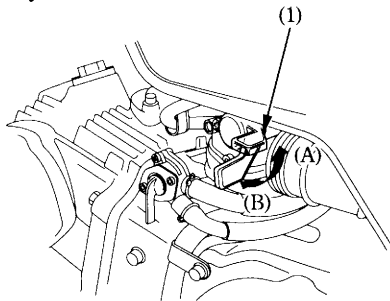

(1) Choke lever

(A) Fully ON

(B) Fully OFF

2. With the throttle slightly open, operate the kickstarter. Kick from the top of the stroke through to the bottom with a rapid, continuous motion.

CAUTION:

*** Allowing the kickstarter to snap back freely against the pedal stop can damage the engine case.**

3. Warm up the engine by opening and closing the throttle slightly.
4. About a half minute after the engine starts, push the choke lever (1) down all the way to Fully OFF (B).
5. If idling is unstable, open the throttle slightly.

High Air Temperature

35 °C (95 °F) or above

1. Do not use the choke.
2. Start the engine following step 2 under “Normal Air Temperature.”

Low Air Temperature

10°C (50°F) or below

1. Follow steps 1 – 2 under “Normal Air Temperature.”
2. Warm up the engine by opening and closing the throttle slightly.
3. Continue warming up the engine until it runs smoothly and responds to the throttle when the choke lever (1) is at Fully OFF (B).

CAUTION:

*** Extended use of the choke may impair piston and cylinder wall lubrication and damage the engine.**

Flooded Engine

If the engine fails to start after repeated attempts, it may be flooded with excess fuel. To clear a flooded engine, turn the engine stop switch to OFF and push the choke lever down to Fully OFF (B). Open the throttle fully and crank the engine several times with the kickstarter. Turn the engine stop switch to RUN and open the throttle slightly; start the engine using the kickstarter.

RUNNING-IN

Help assure your motorcycle's future reliability and performance by paying extra attention to how you ride during the first 500 km (300 miles).

During this period, avoid full-throttle starts and rapid acceleration.

RIDING

▲WARNING

- * Review Motorcycle Safety (pages 1 – 5) before you ride.
- * Make sure the side stand is fully retracted before riding the motorcycle. If the stand is extended, it may interfere with control during a left turn.

NOTE:

- * Make sure you understand the function of the side stand mechanism. (See MAINTENANCE SCHEDULE on page 40 and explanation for SIDE STAND on page 63)

1. Warm up the engine.
2. With the engine idling, shift into low (1st) by depressing the heel end of the gearshift pedal.
3. Slowly open the throttle to start the motorcycle rolling smoothly, and when the motorcycle attains a moderate speed, close the throttle and depress the gearshift pedal with the heel to shift

into 2nd gear.

4. This sequence is repeated to progressively shift into the next higher gear.
5. Shifting down is accomplished by depressing the toe end of the gearshift pedal.
6. Coordinate the throttle and brakes for smooth deceleration.
7. Both front and rear brakes should be used at the same time and should not be applied strongly enough to lock the wheel, or braking effectiveness will be reduced and control of the motorcycle be difficult.

TOE END

HEEL END

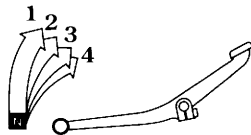

High-Low Speed Range Selector Lever (UB,NZ type)

The speed range selector lever (1) is located on the left crankcase cover at the bottom side of the posi-torque cover. When additional power is required for climbing a steep grade or riding with a heavy load, shifting the selector lever to the “L” range will provide the necessary power.

To shift posi – torque:

1. Stop the engine.
2. Place main transmission in neutral.
3. Move rear wheel fast by hand while turning selector lever.

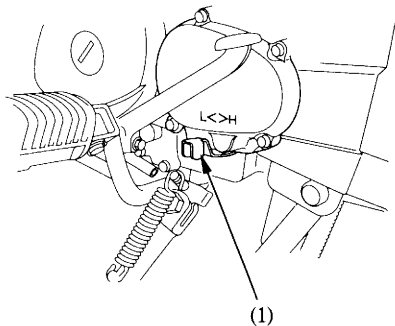

(1) Speed range selector lever

BRAKING

1. For normal braking, gradually apply both the front and rear brakes while downshifting to suit your road speed.
2. For maximum deceleration, close the throttle and apply the front and rear brakes firmly.

▲WARNING

- * Independent use of only the front or rear brake reduces stopping performance. Extreme braking may cause either wheel to lock, reducing control of the motorcycle.
- * When possible, reduce speed or brake before entering a turn; closing the throttle or braking in mid-turn may cause wheel slip. Wheel slip will reduce control of the motorcycle.

▲WARNING

- * When riding in wet or rainy conditions, or on loose surfaces, the ability to maneuver and stop will be reduced. All of your actions should be smooth under these conditions. Rapid acceleration, braking or turning may cause loss of control. For your safety, exercise extreme caution when braking, accelerating or turning.
- * When descending a long, steep grade, use engine compression braking by downshifting, with intermittent use of both brakes. Continuous brake application can overheat the brakes and reduce their effectiveness.
- * Riding with your foot resting on the brake pedal or your hands on the brake lever may actuate the brakelight, giving a false indication to other drivers. It may also overheat the brake, reducing effectiveness.

PARKING

1. After stopping the motorcycle, shift the transmission into neutral, turn the fuel cock OFF, turn the handlebar fully to the left, turn the ignition switch OFF and remove the key.
2. Use the side or center stand to support the motorcycle while parked.

CAUTION:

- * **Park the motorcycle on firm, level ground to prevent it from falling over.**
 - * **If you must park on a slight incline, aim the front of the motorcycle uphill to reduce the possibility of rolling off the side stand or overturning.**
3. Lock the steering to help prevent theft (page 26). (UY type)

ANTI-THEFT TIPS

1. Always lock the steering and never leave the key in the ignition switch. This sounds simple but people do forget.
2. Be sure the registration information for your motorcycle is accurate and current.
3. Park your motorcycle in a locked garage whenever possible.
4. Use an additional anti-theft device of good quality.
5. Put your name, address, and phone number in this Owner's Manual and keep it on your motorcycles at all times. Many times stolen motorcycles are identified by information in the Owner's Manuals that are still with them.

NAME: _____

ADDRESS: _____

PHONE NO: _____

MAINTENANCE

- When service is required, remember that your Honda dealer knows your motorcycle best and is fully equipped to maintain and repair it. The scheduled maintenance may be performed by a qualified service facility that normally does this kind of work; or you may perform most of the work yourself if you are mechanically qualified.
- These instructions are based on the assumption that the motorcycle will be used exclusively for its designed purpose. Sustained high speed operation, or operation in unusually wet or dusty conditions, will require more frequent service than specified in the MAINTENANCE SCHEDULE. Consult your Honda dealer for recommendations applicable to your individual needs and use.

MAINTENANCE SCHEDULE

The following Maintenance Schedule specifies all maintenance required to keep your motorcycle in peak operating condition. Maintenance work should be performed in accordance with standards and specifications of Honda by properly trained and equipped technicians. Your Honda dealer meets all of these requirements.

Perform the Pre-ride Inspection (page 30) at each scheduled maintenance period.

I: INSPECT AND CLEAN, ADJUST, LUBRICATE OR REPLACE IF NECESSARY

C: CLEAN R: REPLACE A: ADJUST L: LUBRICATE

ITEMS	FREQUENCY	WHICHEVER → COMES FIRST ↓ NOTE	ODOMETER READING [NOTE (1)]					Refer to pages
			×1,000 km	1	4	8	12	
			×1,000 mi MONTHS	0.6	2.5	5	7.5	
* FUEL LINE								
* FUEL STRAINER SCREEN				I	I	I		–
* THROTTLE OPERATION				C	C	C		–
AIR CLEANER		NOTE (2)		I	I	I		55
CRANKCASE BREATHER		NOTE (3)(4)		C	C	C		46
SPARK PLUG				C	C	C		–
* VALVE CLEARANCE				I	R	I		51–52
ENGINE OIL			I	I	I	I		53–54
** ENGINE OIL STRAINER SCREEN			R	R	R	R		48–50
* CAM CHAIN TENSION						C		–
* ENGINE IDLE SPEED			A	A	A	A		57
			I	I	I	I		56

ITEMS	FREQUENCY	WHICHEVER → COMES FIRST ↓ NOTE	ODOMETER READING [NOTE (1)]					
			×1,000 km	1	4	8	12	Refer
			×1,000 mi	0.6	2.5	5	7.5	to
			MONTHS		6	12	18	pages
		NOTE (3)	EVERY 1,000km (600mi) I, L				58-61	
	DRIVE CHAIN	NOTE (5)		I	I	I	71-72	
	BATTERY			I	I	I	68	
	BRAKE SHOE WEAR			I	I	I	11-13	
	BRAKE SYSTEM			I	I	I	75	
*	BRAKE LIGHT SWITCH			I	I	I	28	
*	HEADLIGHT AIM			I	I	I	15	
	CLUTCH SYSTEM			I	I	I	63	
	SIDE STAND			I	I	I	62	
*	SUSPENTION			I		I	-	
*	NUTS,BOLTS,FASTENERS	NOTE (3)		I	I	I	-	
**	WHEELS/TYRES	NOTE (3)		I	I	I	-	
**	STEERING HEAD BEARINGS			I		I	-	

- * Should be serviced by your Honda dealer, unless the owner has the proper tools and service data and is mechanically qualified. Refer to the Official Honda Shop Manual.
- * * In the interest of safety, we recommend these items be serviced only by your Honda dealer.

Honda recommends that your Honda dealer should road test your motorcycle after each periodic maintenance is carried out.

- NOTES:
- (1) At higher odometer readings, repeat at the frequency interval established here.
 - (2) Service more frequently if the motorcycle is ridden in unusually wet or dusty areas.
 - (3) Service more frequently when riding OFF-ROAD.
 - (4) NZ type
 - (5) UB, NZ type

TOOL KIT (UY type)

The tool kit (1) is in the tool compartment (2) under the rear carrier.

Some roadside repairs, minor adjustments and parts replacement can be performed with the tools contained in the kit.

- 10 × 12 mm open end wrench
- 14 × 17 mm open end wrench
- Pliers
- Standard/Phillips screwdriver
- Spark plug wrench
- Screwdriver grip
- Handle lever
- Tool bag

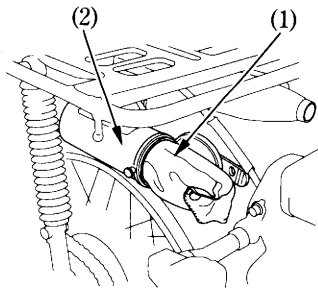

- (1) Tool kit
- (2) Tool compartment

TOOL KIT (UB,NZ type)

The tool kit (1) is behind the right side cover.

Some roadside repairs, minor adjustments and parts replacement can be performed with the tools contained in the kit.

- 10 × 12 mm open end wrench
- 14 × 17 mm open end wrench
- Plier
- Standard/Phillips screwdriver
- Spark plug wrench
- Screwdriver grip
- Handle lever
- Tool bag

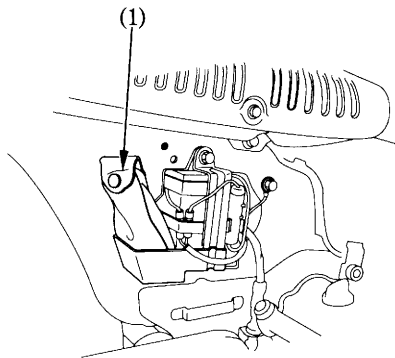

(1) Tool kit

SERIAL NUMBERS

The frame and engine serial numbers are required when registering your motorcycle. They may also be required by your dealer when ordering replacement parts.

Record the numbers here for your reference.

FRAME NO. _____

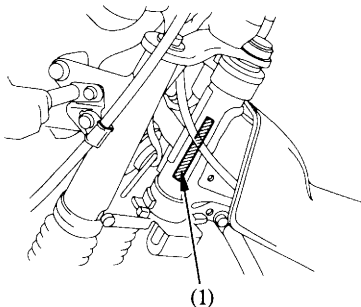

(1) Frame number

The frame number (1) is stamped on the left side of the steering head.

The engine number (2) is stamped on the lower left side of the crankcase.

ENGINE NO. _____

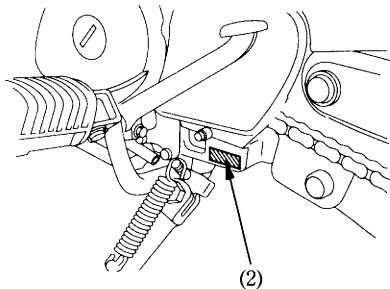

(2) Engine number

MAINTENANCE PRECAUTIONS

▲WARNING

- * If your motorcycle is overturned or involved in a collision, inspect control levers, cables, accessories, and other vital parts for damage. Do not ride the motorcycle if damage impairs safe operation. Have your Honda dealer inspect the major components, including frame, suspension and steering parts, for misalignment and damage that you may not be able to detect.
- * Use new, genuine Honda parts or their equivalent for maintenance and repair. Parts which are not of equivalent quality may impair the safety of your motorcycle.

▲WARNING

- * Stop the engine and support the motorcycle securely on a firm, level surface before performing any maintenance.

AIR CLEANER

(Refer to the maintenance precautions on page 45).

The air cleaner should be serviced at regular intervals (page 39). Service more frequently when riding in unusually wet or dusty areas.

1. Remove the wing nut(1), washer and air cleaner tube clamp screw(2), then remove the air cleaner tube and air cleaner housing cover.

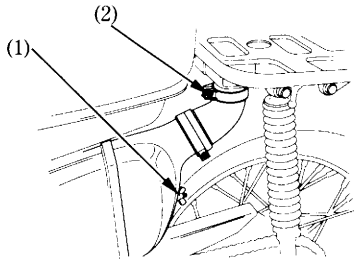

(1) Wing nut

(2) Screws

2. Unscrew the mounting plate bolt(3) and remove the mounting plate(4).
3. Pull out the air cleaner(5).
4. Wash the air cleaner in clean, nonflammable or high flash point solvent and let it dry thoroughly.

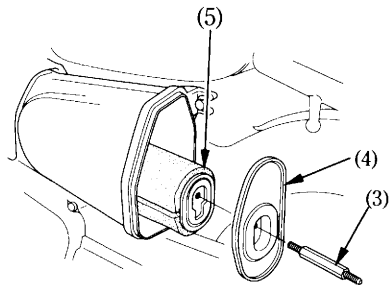

(3) Bolt

(4) Mounting plate

(5) Air cleaner

▲WARNING

*** Never use petrol or low flash point solvents for cleaning the air cleaner. A fire or explosion could result.**

5. Soak the air cleaner in gear oil (SAE 80—90) until saturated, then squeeze out the excess oil.
6. Install the removed parts in the reverse order of removal.

ENGINE OIL

(Refer to the maintenance precautions on page 45).

Engine Oil

Good engine oil has many desirable qualities. Use only high detergent, quality motor oil certified on the container to meet or exceed requirements for service SE or SF. It is not necessary to use additives.

Viscosity:

Viscosity grade of engine oil should be based on average atmospheric temperature in your riding area. The following provides a guide to the selection of the proper grade or viscosity of oil to be used at various atmospheric temperatures.

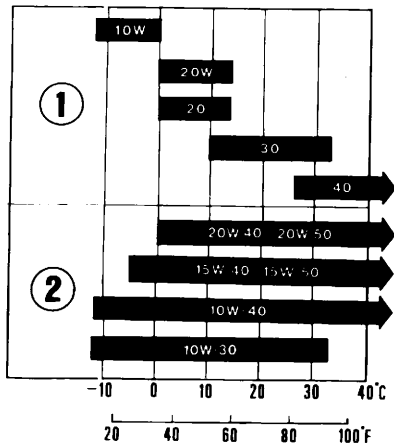

(1) Single grade

(2) Multigrade

Engine Oil

Engine oil quality is the chief factor affecting engine service life. Change the engine oil as specified in the maintenance schedule (page 39).

NOTE:

- * Change the engine oil with the engine at normal operating temperature and the motorcycle on its center stand to assure complete and rapid draining.

1. To drain the oil, remove the oil filler cap and oil drain plug (1) and sealing washer (2).

▲WARNING

- * A warmed-up engine and the oil in it are hot; be careful not to burn yourself.

2. With the engine stop switch OFF, operate the kickstarter several times to drain any oil which may be left in the engine.

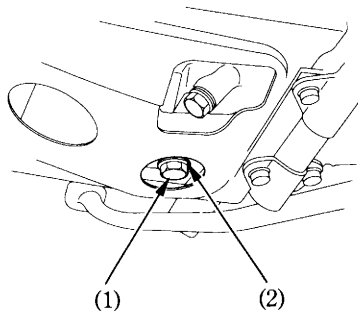

(1) Drain plug

(2) Sealing washer

3. Check that the sealing washer on the drain plug is in good condition and install the plug. Replace the sealing washer every other time the oil is changed, or each time if necessary.

Oil Drain Plug Torque:

25 N·m (2.5 kgf·m , 18 lbf·ft)

4. Fill the crankcase with the recommended grade oil; approximately:
0.9 ℓ (1.0 US qt , 0.8 Imp qt)
5. Install the oil filler cap/dipstick.
6. Start the engine and let it idle for 2–3 minutes.
7. Stop the engine and check that the oil level is at the upper level mark on the dipstick with the motorcycle upright on firm, level ground. Make sure there are no oil leaks.

NOTE:

- * When running in very dusty conditions, oil changes should be performed more frequently than specified in the maintenance schedule.
- * Please dispose of used engine oil in a manner that is compatible with the environment. We suggest you take it in a sealed container to your local recycling center or service station for reclamation. Do not throw it in the rubbish or pour it on the ground or down a drain.

CAUTION:

- * **Used engine oil may cause skin cancer if repeatedly left in contact with the skin for prolonged periods. Although this is unlikely unless you handle used oil on a daily basis, it is still advisable to thoroughly wash your hands with soap and water as soon as possible after handling used oil.**

SPARK PLUG

(Refer to the maintenance precautions on page 45).

Recommended plugs:

Standard:

DR8ES-L (NGK) or
X24ESR-U (DENSO)

For cold climate: (Below 5 °C, 41 °F)

DR7ES (NGK) or
X22ESR-U (DENSO)

For extended high speed riding:

DR8ES (NGK) or
X27ESR-U (DENSO)

1. Disconnect the spark plug cap (1) from the spark plug.
2. Clean any dirt from around the spark plug base. Remove the spark plug using the plug wrench (2) furnished in the tool kit.
3. Inspect the electrodes and center porcelain for deposits, erosion or carbon fouling. If the erosion or deposit is heavy, replace the plug. Clean a carbon or wet-fouled plug with a plug cleaner, otherwise use a wire brush.

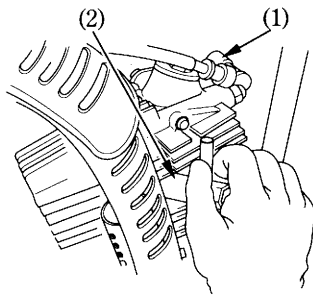

(1) Spark plug cap

(2) Plug wrench

4. Check the spark plug gap (3) using a wire-type feeler gauge. If adjustment is necessary, bend the side electrode (4) carefully.

The gap should be:

0.60–0.70 mm (0.024–0.028 in)

Make sure the plug washer is in good condition.

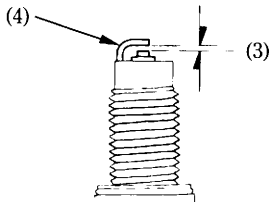

(3) Spark plug gap

(4) Side electrode

5. With the plug washer attached, thread the spark plug in by hand to prevent cross-threading.
6. Tighten a new spark plug 1/2 turn with a spark plug wrench to compress the washer. If you are reusing a plug, it should only take 1/8–1/4 turn after the plug seats.
7. Reinstall the spark plug cap.

CAUTION:

- * The spark plug must be securely tightened. An improperly tightened plug can become very hot and possibly damage the engine.
- * Never use a spark plug with an improper heat range. Severe engine damage could result.

VALVE CLEARANCE

(Refer to the maintenance precautions on page 45).

Excessive valve clearance will cause noise and eventual engine damage. Little or no clearance will prevent the valve from closing and cause valve damage and power loss. Check valve clearance when the engine is cold at the specified intervals.

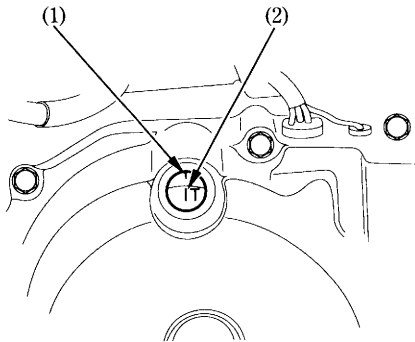

(1) Index mark

(2) T mark

NOTE:

* The checking or adjusting of the clearance should be performed while the engine is cold. The clearance will change as the engine temperature rises.

1. Remove the cran shaft hole cap and timing hole cap.
2. Remove the adjusting caps .
3. Rotate the generator flywheel counterclockwise until the T mark (2) on the flywheel lines up with the index mark (1) on the timing hole. In this position, the piston may either be on the compression or exhaust stroke.

The adjustment must be made when the piston is at the top of the compression stroke when both the intake and exhaust valves are closed.

This condition can be determined by moving the rocker arms. If they are free, it is an indication that the valves are closed and that the piston is on the compression stroke. If they are tight and the valves are open, rotate the flywheel 360° and realign the T mark to the index mark.

Check the clearance of both valves by inserting a feeler gauge (3) between the adjusting screw (4) and the valve stem. Clearance should be:

Intake: 0.05 mm (0.002 in)

Exhaust: 0.05 mm (0.002 in)

If it is necessary to make an adjustment, loosen the adjusting screw lock nut (5) and turn the adjusting screw (4) so there is a slight resistance when the feeler gauge (3) is inserted.

After completing the adjustment, tighten the adjusting screw lock nut while holding the adjusting screw to prevent it from turning. Finally, recheck the clearance to make sure that the adjustment has not been disturbed. Reinstall the adjusting caps.

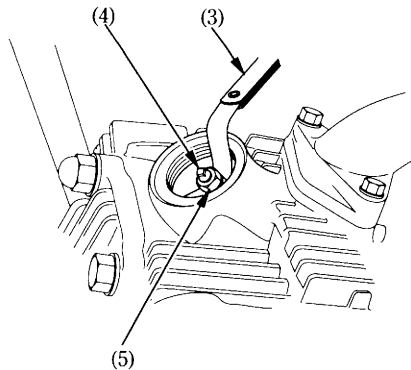

(3) Feeler gauge
(4) Adjusting screw

(5) Adjusting screw
lock nut

THROTTLE OPERATION

(Refer to the maintenance precautions on page 45).

1. Check for smooth rotation of the throttle grip from the fully open to the fully closed position at both full steering positions.
2. Measure the throttle grip free play at the throttle grip flange.

The standard free play should be approx:
3–5 mm (0.1–0.2 in)

To adjust the free play, loosen the lock nut (1) and turn the adjuster (2).

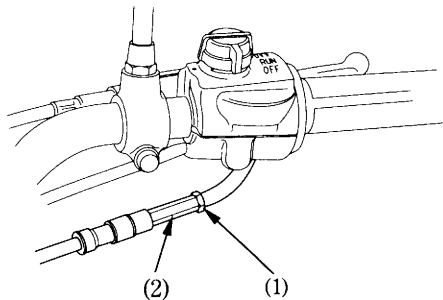

- (1) Lock nut
(2) Adjuster

IDLE SPEED

(Refer to the maintenance precautions on page 45).

The engine must be at normal operating temperature for accurate idle speed adjustment. Ten minutes of stop-and-go riding is sufficient.

NOTE:

* Do not attempt to compensate for faults in other systems by adjusting idle speed. See your Honda dealer for regularly scheduled carburetor adjustments.

1. (UY type)

Warm up the engine, shift to neutral and place the motorcycle on its center stand.

(UB, NZ type)

Warm up the engine, shift to neutral and place the motorcycle on its side stand.

2. Connect a tachometer to the engine.

3. Adjust idle speed with the throttle stop screw (1).

Idle Speed (in neutral):

$1,500 \pm 100 \text{ min}^{-1} \text{ (rpm)}$

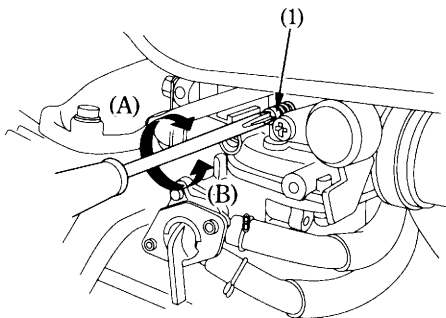

(1) Throttle stop screw

(A) Increase

(B) Decrease

CAM CHAIN ADJUSTMENT

(Refer to the maintenance precautions on page 45).

When the cam chain is noisy, adjust the tension in the following manner:

1. Start the engine and maintain it at idle speed ($1,500 \text{ min}^{-1}$).
2. Loosen the lock nut (1), and loosen the tensioner adjusting bolt (2) approximately one half turn. Tighten the lock nut.

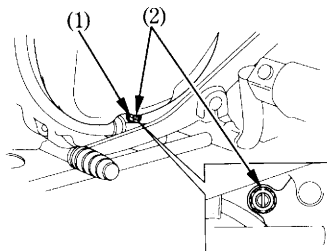

- (1) Tensioner adjusting bolt lock nut
(2) Tensioner adjusting bolt

3. If the chain is still noisy even after the above adjustment, loosen the lock nut (1) adjusting bolt (2) and the 14mm sealing bolt (3) located at the bottom of the crankcase, and screw in the tensioner bolt (4) gradually with the engine running, until the cam chain becomes quiet. After completing the adjustment, tighten the tensioner adjusting bolt, lock nut, and 14 mm sealing bolt securely.

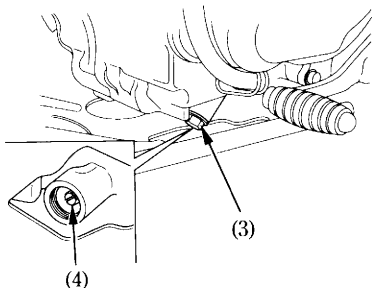

- (3) 14mm sealing bolt
(4) Tensioner bolt

DRIVE CHAIN

(Refer to the maintenance precautions on page 45).

The service life of the drive chain is dependent upon proper lubrication and adjustment. Poor maintenance can cause premature wear or damage to the drive chain and sprockets.

The drive chain should be checked and lubricated as part of the Pre-ride Inspection (page 30). Under severe usage, or when the motorcycle is ridden in unusually dusty or muddy areas, more frequent maintenance will be necessary.

Inspection:

1. (UY type)

Turn the engine off, place the motorcycle on its center stand, and shift the transmission into neutral.

(UB, NZ type)

Turn the engine off, raise the rear wheel off the ground by placing a support under the engine, and shift the transmission into neutral.

2. (UY, NZ type)

Check slack in the lower drive chain run midway between the sprockets.

Drive chain slack should be adjusted to allow the following vertical movement by hand:

15 – 25 mm (0.6 – 1.0 in)

(UB type)

Remove the inspection cap (2). Move the chain (1) up and down with your finger. Drive chain slack should be adjusted approximately to allow the following vertical movement by hand:

15 – 25 mm (0.6 – 1.0 in)

(UY, NZ type)

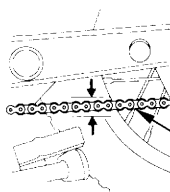

(1) Drive chain

(UB type)

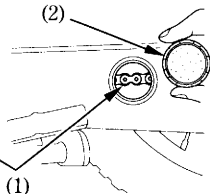

(2) Inspection cap

3. Rotate the rear wheel. Stop. Check the drive chain slack. Repeat this procedure several times. Drive chain slack should remain constant. If the chain is slack only in certain sections, some links are kinked and binding. Binding and kinking can frequently be eliminated by lubrication.
4. Inspect the sprocket teeth for possible wear or damage. Replace if necessary.

NOTE:

- * If the drive chain or sprockets are excessively worn or damaged, they should be replaced. Never use a new chain with worn sprockets; rapid chain wear will result.

Damaged Sprocket
Teeth

REPLACE

Worn Sprocket
Teeth

REPLACE

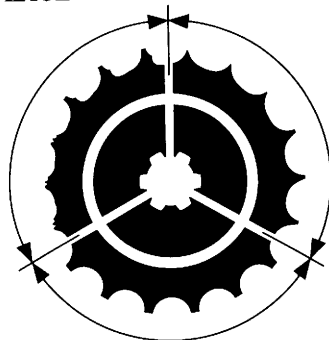

Normal Sprocket Teeth

GOOD

Adjustment:

If the drive chain requires adjustment, the procedure is as follows:

1. Remove the cotter pin (UB, NZ type) and loosen the rear axle nut (1).
2. Turn the adjusting nut (4) on both the right and left chain adjusters an equal number of turns to increase or decrease chain slack.

Align the chain adjuster index marks (2) with the corresponding scale (3) graduations on both sides of the swing arm.

NOTE:

- * If the drive chain slack is excessive when the rear axle is moved to the furthest limit of adjustment, the drive chain is worn and must be replaced.

3. Torque the rear axle nut to :
(UB, NZ type)
52 N·m (5.3 kgf·m , 38 lbf·ft)
(UY type)
88 N·m (9.0 kgf·m , 65 lbf·ft)
4. Tighten the adjusting nuts.

5. Recheck drive chain slack.
6. Install a new cotter pin. (UB, NZ type)
7. Rear brake pedal free play is affected when repositioning the rear wheel to adjust drive chain slack. Check rear brake pedal free play and adjust as necessary (page 13).

CAUTION: (UB, NZ type)

- * Used cotter pins may not effectively secure fasteners. Always replace used cotter pins with new ones.

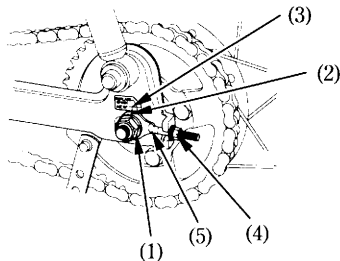

- | | |
|--------------------------|--------------------|
| (1) Rear axle nut | (4) Adjusting nut |
| (2) Adjusting index mark | (5) Chain adjuster |
| (3) Graduated scale | |

Lubrication and cleaning:

Lubricate every 1,000 km (600 miles) or sooner if chain appears dry.

The O-rings in this chain can be damaged by steam cleaning, high pressure washers, and certain solvents. Clean the side surfaces of the chain with a dry cloth. Do not brush the rubber O-rings. Brushing will damage them. Wipe dry and lubricate only with SAE 80 or 90 gear oil. Commercial chain lubricants may contain solvents which could damage the rubber O-rings.

Replacement Chain:

DID428VC2 (UY type)

DID428I or RK428 (UB,NZ type)

CAUTION:

* The drive chain on this motorcycle is equipped with small O-rings between the link plates. These O-rings retain grease inside the chain to improve its service life. However, special precautions must be taken when adjusting, lubricating, washing, and replacing the chain.

(UY,NZ type)

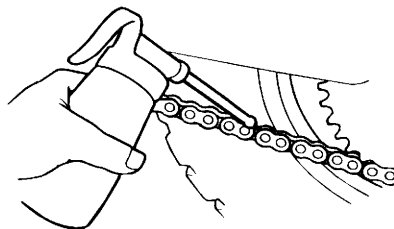

(UB type)

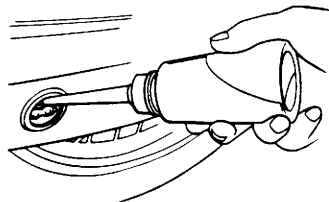

FRONT AND REAR SUSPENSION INSPECTION

(Refer to the maintenance precautions on page 45).

1. Check the front fork assembly by locking the front brake and pumping the fork up and down vigorously. Suspension action should be smooth.
2. Rear fork bushing—this can be checked by pushing hard against the side of the rear wheel while the motorcycle is on the center stand and feeling for looseness of the fork bushings.
3. Carefully inspect all front and rear suspension fasteners for tightness.

SIDE STAND

(Refer to the maintenance precautions on page 45).

Check the side stand spring (1) for damage and loss of tension, and the side stand assembly for freedom of movement.

If the side stand is squeaky or stiff, clean the pivot area and lubricate the pivot bolt with clean engine oil.

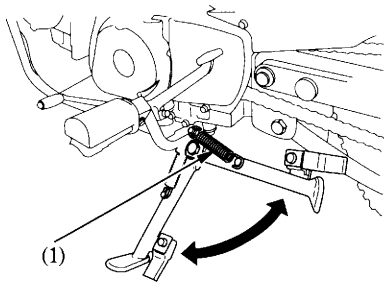

(1) Side stand spring

Check the rubber pad for deterioration and wear. Replace if wear extends to the wear line (See (2) in the picture). Check the side stand assembly for freedom of movement. If parts must be replaced, please contact your HONDA dealer.

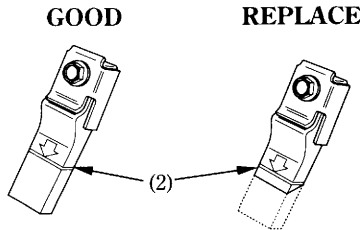

(2) Wear line

WHEEL REMOVAL

Front Wheel Removal

(Refer to the maintenance precautions on page 45).

1. Raise the front wheel off the ground by placing a support block under the engine.
2. Remove the speedometer cable (1).
3. Remove the front brake adjusting nut (2) and remove the front brake cable (3) from the brake arm.

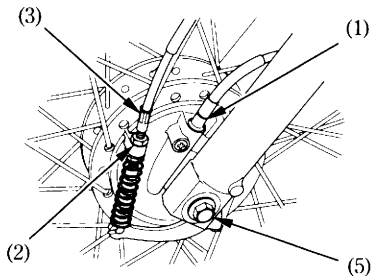

- (1) Speedometer cable (3) Front brake cable
(2) Brake adjusting nut (5) Axle

4. Remove the cotter pin (UB,NZtype) and axle nut (4).
5. Remove the axle (5) and the wheel.

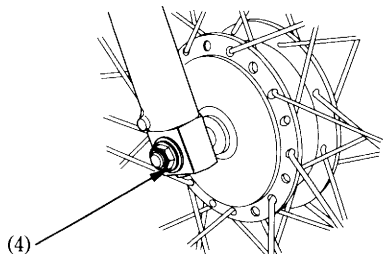

- (4) Front axle nut

Installation Notes:

- Reverse the removal procedure.
- Make sure that the tang (5) on the left fork leg is located in the brake panel.
- Tighten the axle nut to the specified torque.
- Axle nut torque:
(UB,NZ type)
52 N·m (5.3 kgf·m , 38 lbf·ft)
(UY type)
59 N·m (6.0 kgf·m , 43 lbf·ft)
- Adjust the brake (page 11 – 13).
- After installing the wheel , apply the brake several times and check for free wheel rotation when released.

▲WARNING

- * If a torque wrench was not used for installation, see your Honda dealer as soon as possible to verify proper assembly. Improper assembly may lead to loss of braking capacity.

CAUTION: (UB,NZ type)

- * Used cotter pins may not effectively secure fasteners. Always replace used cotter pins with new ones.

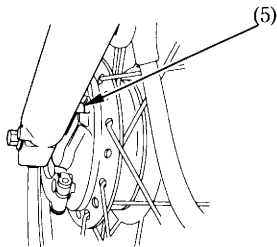

(5) Tang

Rear Wheel Removal

(Refer to the maintenance precautions on page 45).

1. (UY type)

Place the motorcycle on its center stand.

(UB,NZ type)

Raise the rear wheel off the ground by placing a support block under the engine.

2. Remove the rear brake adjusting nut (1).

Disconnect the brake rod (2) from the brake arm (3).

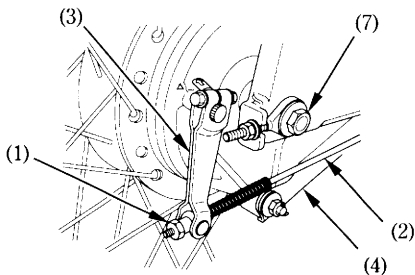

(1) Adjusting nut

(2) Brake rod

(3) Brake arm

(4) Stopper arm

(7) Axle

3. Disconnect the brake stopper arm (4) from the brake panel by removing the cotter pin, stopper arm nut, washer and rubber grommet.

4. Loosen the drive chain adjusting nuts (5).

5. Remove the cotter pin (UB,NZ type) and axle nut (6) and pull out the rear axle (7).

Push the wheel forward and remove the drive chain from the rear sprocket.

6. Pull out the wheel from the swingarm.

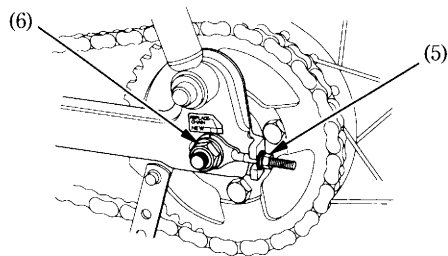

(5) Adjusting nuts

(6) Axle nut

Installation Notes:

- Reverse the removal procedure.
- Tighten the axle nut and stopper arm nut to specified torque.

Axle nut torque:

(UB,NZ type)

52 N·m (5.3 kgf·m , 38 lbf·ft)

(UY type)

88 N·m (9.0 kgf·m , 65 lbf·ft)

- Adjust the brake (page 13) and drive chain (page 58).
- After installing the wheel , apply the brakes several times , and check for free wheel rotation when released.

▲WARNING

- * If a torque wrench was not used for installation, see your Honda dealer as soon as possible to verify proper assembly. Improper assembly may lead to loss of braking capacity.

CAUTION:

- * **Used cotter pins may not effectively secure fasteners. Always replace used cotter pins with new ones.**

BRAKE SHOE WEAR

(Refer to the maintenance precautions on page 45).

The front and rear brakes are equipped with brake wear indicators.

When the brake is applied, an arrow (1) attached to the brake arm (2) moves toward a reference mark (3) on the brake panel (4). If the arrow aligns with the reference mark on full application of the brake, the brake shoes must be replaced.

See your Honda dealer for this service.

NOTE:

- * When the brake service is necessary, see your Honda dealer. Use only genuine Honda parts or its equivalent.

< FRONT BRAKE >

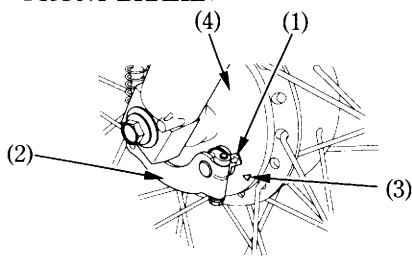

< REAR BRAKE >

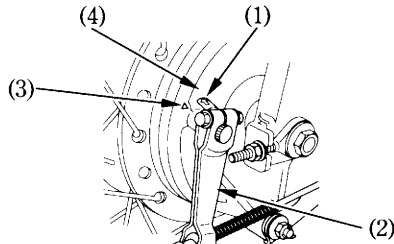

- (1) Arrow
- (2) Brake arm

- (3) Reference mark
- (4) Brake panel

BATTERY (UY type)

(Refer to the maintenance precautions on page 45).

It is not necessary to check the battery electrolyte level or add distilled water as the battery is a maintenance-free (sealed) type. If your battery seems weak and/or is leaking electrolyte (causing hard starting or other electrical troubles), contact your Honda dealer.

CAUTION:

- * Removing the battery cap strip can damage the cap strip and result in leaks and eventual battery damage.
- * When the motorcycle is to be stored for an extended period of time, remove the battery from the motorcycle and charge it fully. Then store it in a cool, dry place. If the battery is to be left in the motorcycle, disconnect the negative cable from the battery terminal.

▲WARNING

- * The battery gives off explosive gases; keep sparks, flames, and cigarettes away. Provide adequate ventilation when charging or using the battery in an enclosed space.
- * The battery contains sulfuric acid (electrolyte). Contact with skin or eyes may cause severe burns. Wear protective clothing and a face shield.
 - If electrolyte gets on your skin, flush with water.
 - If electrolyte gets in your eyes, flush with water for at least 15 minutes and call a physician immediately.
- * Electrolyte is poisonous.
 - If swallowed, drink large quantities of water or milk and follow with milk of magnesia or vegetable oil and call a physician.
- * **KEEP OUT OF REACH OF CHILDREN.**

Removal:

1. Remove the right side cover by removing the screw (page 29).
2. Remove the bolt (1).
3. Unhook the positive (+) terminal lead from the hook (2).
4. Press on the locking tabs (3) and open the battery case cover (4).

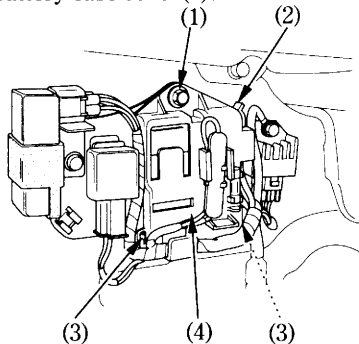

- (1) Bolt
(2) Hook
(3) Locking tabs
(4) Battery case cover

5. Pull out the battery (5).
6. Remove the bolt and disconnect the negative (-) terminal lead (6) from the battery.
7. Remove the bolt and disconnect the positive (+) terminal (7) and from the battery.
8. Remove the battery.

Installation:

Install the removed parts in the reverse order of removal.

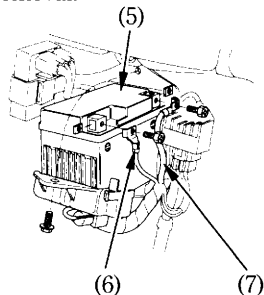

- (5) Battery
(6) Negative (-) terminal lead
(7) Positive (+) terminal lead

BATTERY (UB,NZ type)

(Refer to the maintenance precautions on page 45).

If the motorcycle is operated with insufficient battery electrolyte, sulfation and battery plate damage will occur.

If rapid loss of electrolyte is experienced, or if your battery seems to be weak, causing electrical problems, see your authorized Honda dealer.

Battery electrolyte:

The battery (1) is behind the right side cover.

Remove the right side cover (page 28).

Check the electrolyte level with the motorcycle in an upright position on level ground. The electrolyte level must be maintained between the UPPER (2) and LOWER (3) level marks on the side of the battery.

If the electrolyte level is low,remove the bolt and open the battery holder.

Pull out the battery. Remove the battery filler caps (4).

Carefully add distilled water to the UPPER level mark, using a small syringe or plastic funnel.

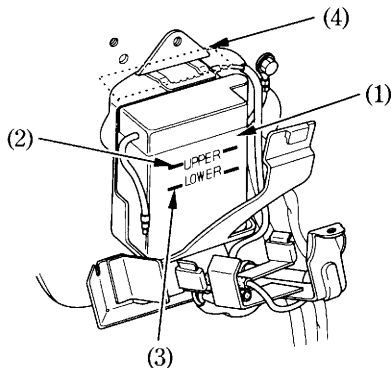

- (1) Battery
- (2) UPPER level
- (3) LOWER level

- (4) Filler caps

CAUTION:

- * When checking the battery electrolyte level or adding distilled water, make sure the breather tube is connected to the battery breather outlet.
- * Use only distilled water in the battery. Tap water will shorten the service life of the battery.
- * Filling the battery above the UPPER LEVEL line may cause the electrolyte to overflow, resulting in corrosion to engine or frame parts. Immediately wash off any spilled electrolyte.
- * The battery breather tube must be routed as shown on the label. Do not bend or twist the breather tube. A bent or kinked breather tube may pressurize the battery and damage its case.

▲ WARNING

- * The battery gives off explosive gases; keep sparks, flames, and cigarettes away. Provide adequate ventilation when charging or using the battery in an enclosed space.
- * The battery contains sulfuric acid (electrolyte). Contact with skin or eyes may cause severe burns. Wear protective clothing and a face shield.
 - If electrolyte gets on your skin, flush with water.
 - If electrolyte gets in your eyes, flush with water for at least 15 minutes and call a physician immediately.
- * Electrolyte is poisonous.
 - If swallowed, drink large quantities of water or milk and follow with milk of magnesia or vegetable oil and call a physician.
- * **KEEP OUT OF REACH OF CHILDREN.**

FUSE REPLACEMENT

(Refer to the maintenance precautions on page 45).

The fuse holder (1) is attached to the battery case cover.

The specified fuse are follows:

7A (UY type)

10A (UB,NZ type)

When frequent fuse failure occurs, it usually indicates a short circuit or an overload in the electrical system. See your Honda dealer for repair.

CAUTION:

- * Turn the ignition switch OFF before checking or replacing fuse to prevent accidental short-circuiting.
- * Do not pry the clips open to get a fuse out; you could bend them and cause poor contact with the new fuse. A loose fuse could cause damage to the electrical system and even start a fire.

▲WARNING

- * Never use a fuse with a different rating from that specified. Serious damage to the electrical system or a fire may result, causing a dangerous loss of lights or engine power.

(UY type)

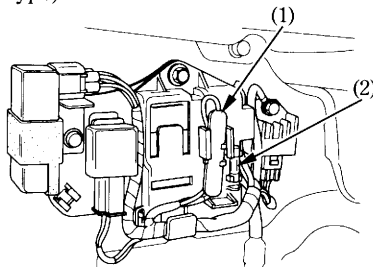

- (1) Fuse holder
(2) Spare fuse

To replace the fuse , open the fuse holder and lift out the fuse with the clips. Slide the old fuse out of the clips and discard it. Slide the clips onto the ends of the new fuse, push them back into the fuse holder, and close the fuse holder.

(UB,NZ type)

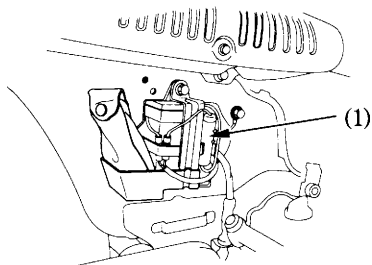

(1) Fuse holder

REMOVAL

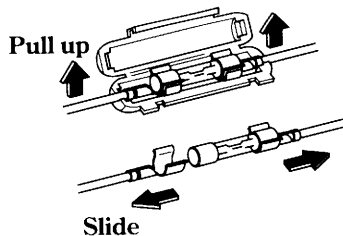

INSTALLATION

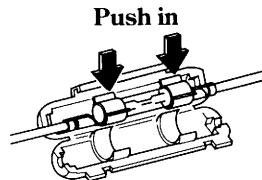

STOPLIGHT SWITCH ADJUSTMENT

(Refer to the maintenance precautions on page 45).

Check the operation of the stoplight switch (1) is below the right side cover, near the engine from time to time.

Adjustment is done by turning the adjusting nut (2). Turn the nut in the direction (A) if the switch operates too late and in direction (B) if the switch operates too soon.

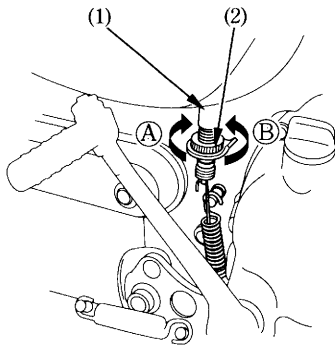

- (1) Stoplight switch
- (2) Adjusting nut

CLEANING

Clean your motorcycle regularly to protect the surface finishes and inspect for damage, wear and oil leakage.

CAUTION:

*** High pressure water (or air) can damage certain parts of the motorcycle.**

Avoid spraying high pressure water (typical in coin-operated car washes) at the following areas:

Wheel Hubs	Under Fuel Tank
Carburetors	Handlebar Switches
Instruments	Steering Lock
Under Seat	(UY type)
Drive Chain	
Ignition Switch	
Muffler Outlets	

1. After cleaning, rinse the motorcycle thoroughly with plenty of clean water. Strong detergent residue can corrode alloy parts.

NOTE:

*** Clean the plastic parts using a cloth or sponge dampened with a solution of mild detergent and water. Rub the soiled area gently rinsing it frequently with fresh water.**

2. Dry the motorcycle, start the engine, and let it run for several minutes.
3. Lubricate the drive chain immediately after washing and drying the motorcycle.
4. Test the brakes before riding the motorcycle. Several applications may be necessary to restore normal braking performance.

▲WARNING

*** Braking efficiency may be temporarily impaired immediately after washing the motorcycle. Anticipate longer stopping distance to avoid a possible accident.**

STORAGE GUIDE

Extended storage, such as for winter, requires that you take certain steps to reduce the effects of deterioration from non-use of the motorcycle. In addition, necessary repairs should be made **BEFORE** storing the motorcycle; otherwise, these repairs may be forgotten by the time the motorcycle is removed from storage.

STORAGE

1. Change the engine oil.
2. Drain the fuel tank and carburetor into an approved petrol container. Spray the inside of the fuel tank with an aerosol rust-inhibiting oil.
Reinstall the fuel fill cap on the tank.

NOTE:

- * If storage will last more than one month, carburetor draining is very important, to assure proper performance after storage.

▲WARNING

- * **Petrol is extremely flammable and is explosive under certain conditions. Perform this operation in a well-ventilated area with the engine stopped. Do not smoke or allow flames or sparks in the area where petrol is drained or stored and where the fuel tank is refueled.**

NOTE:

- * When turning the engine over, the Ignition Switch should be OFF and the spark plug placed in its cable cap and grounded to prevent damage to the ignition system.

3. To prevent rusting in the cylinder, perform the following:

- Remove the spark plug cap from the spark plug. Using tape or string, secure the cap to any convenient plastic body part so it is positioned away from the spark plug.
- Remove the spark plug from the engine and store it in a safe place. Do not connect the spark plug to the spark plug cap.
- Pour a tablespoon (15–20 cm³) of clean engine oil into the cylinder and cover the spark plug hole with a piece of cloth.
- Crank the engine several times to distribute the oil.
- Reinstall the spark plug and spark plug cap.

4. Remove the battery. Store in an area protected from freezing temperatures and direct sunlight. Check the electrolyte level (UB, NZ type) and slow charge the battery once a month.

5. Wash and dry the motorcycle. Wax all painted surfaces. Coat chrome with rust-inhibiting oil.

6. Lubricate the drive chain (page 61).

7. Inflate the tyres to their recommended pressures. Place the motorcycle on blocks to raise both tyres off the ground.

8. Cover the motorcycle (don't use plastic or other coated materials) and store in an unheated area, free of dampness with a minimum of daily temperature variation. Do not store the motorcycle in direct sunlight.

REMOVAL FROM STORAGE

1. Uncover and clean the motorcycle.
Change the engine oil if more than 4 months have passed since the start of storage.
2. Charge the battery as required. Install the battery.
3. Drain any excess aerosol rust-inhibiting oil from the fuel tank. Fill the fuel tank with fresh petrol.
4. Perform all Pre-ride Inspection checks (page 30).
Test ride the motorcycle at low speeds in a safe riding area away from traffic.

SPECIFICATIONS

DIMENSIONS

Overall length	1,865 mm (73.4 in)
Overall width	755 mm (29.7 in)
Overall height	1,070 mm (42.1 in) :UY type 1,050 mm (41.3 in) :UB,NZ type
Wheelbase	1,215 mm (47.8 in) :UY type 1,210 mm (47.6 in) :UB,NZ type

WEIGHT

Dry weight	95.0 kg (209.4 lbs) :UY type 87.0 kg (191.8 lbs) :UB,NZ type
------------	---

CAPACITIES

Engine oil	After draining	0.9 ℓ (1.0 US qt , 0.8 Imp qt)
	After disassembly	1.1 ℓ (1.2 US qt , 1.0 Imp qt)
Fuel tank		4.8 ℓ (1.27 US gal , 1.06 Imp gal)
Fuel reserve		0.9 ℓ (0.24 US gal , 0.20 Imp gal)
Passenger capacity		Operator Only no passengers
Maximum weight capacity		109 kg (240 lbs)

ENGINE

Bore and stroke	52.0 × 49.5 mm (2.05 × 1.95 in)
Compression ratio	8.5 : 1
Displacement	105.1 cm ³ (6.41 cu-in)
Spark plug	
Standard	DR8ES-L (NGK) or X24ESR-U (DENSO)
For cold climate (Below 5 °C, 41 °F)	DR7ES (NGK) or X22ESR-U (DENSO)
For extended high speed riding:	DR8ES (NGK) or X27ESR-U (DENSO)
Spark plug gap	0.60–0.70 mm (0.024–0.028 in)
Idle speed	1,500 ± 100 min ⁻¹ (rpm)
Valve clearance (Cold)	Intake 0.05 mm (0.002 in) Exhaust 0.05 mm (0.002 in)

CHASSIS AND SUSPENSION

Caster	27° 15'
Trail	88 mm (3.5 in) :UY type
	80 mm (3.1 in) :UB, NZ type
Tyre size, front	2.75 – 17 41P
Tyre size, rear	2.75 – 17 41P

POWER TRANSMISSION

Primary reduction	3.722
Gear ratio, 1st	2.538
2nd	1.611
3rd	1.190
4th	0.958
Final reduction	3.000
Sub transmission	1.848 :UB, NZ type

ELECTRICAL

Battery	12V – 3AH :UY type
	6V – 4AH :UB, NZ type
Generator	A.C. Generator

LIGHTS

Headlight		12V – 35/35W	:UY type
		6V – 35/36W	:UB, NZ type
Brake/tail light		12V – 21/5W	:UY type
		6V – 17/5.3W	:UB, NZ type
Turn signal light	Front	12V – 10W	:UY type
	Rear	12V – 10W	:UY type
	Front	6V – 8W	:UB, NZ type
	Rear	6V – 8W	:UB, NZ type
Speedmeter lights		12V – 1.7W	:UY type
		6V – 1.7W	:UB, NZ type
Neutral indicator		12V – 3.4W	:UY type
		6V – 3W	:UB, NZ type
Turn signal indicator		12V – 1.7W	:UY type
		6V – 1.7W	:UB, NZ type
Position light		6V – 3W	:UB, NZ type
Highbeam indicator		12V – 1.7W	:UY type
		6V – 1.5W	:UB, NZ type

FUSE

Fuse		7A	:UY type
		10A	:UB, NZ type

NOISE CONTROL SYSTEM (AUSTRALIA ONLY)

TAMPERING WITH THE NOISE CONTROL SYSTEM IS PROHIBITED: Owners are warned that the law may prohibit : (a) The removal or rendering inoperative by any person other than for purposes of maintenance, repair, or replacement, of any device or element of design incorporated into any new vehicle for the purpose of noise control prior to its sale or delivery to the ultimate purchaser or while it is in use; and (b) the use of the vehicle after such device or element of design has been removed or rendered inoperative by any person.

