

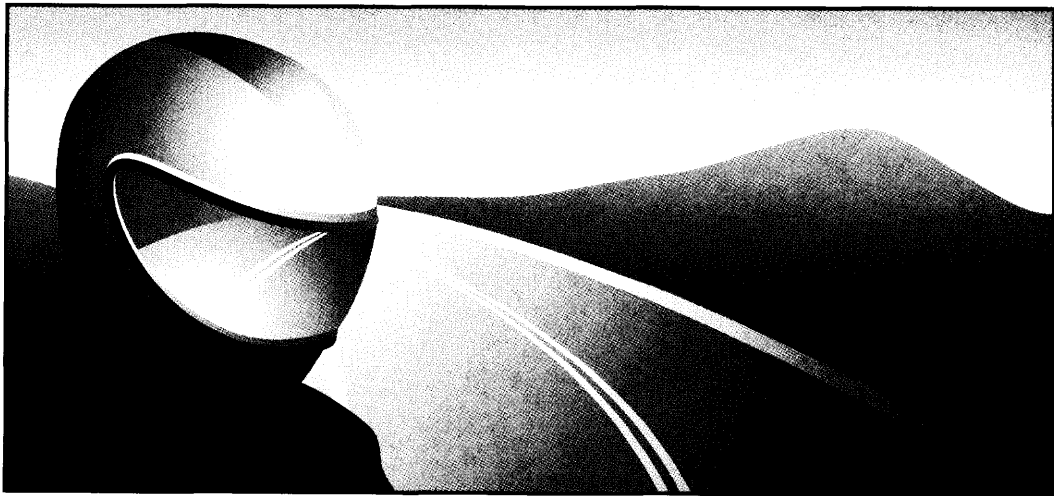

**OWNER'S MANUAL  
USO E MANUTENZIONE  
MANUAL DEL PROPIETARIO**



**NSA700A  
DN-01**



**Honda NSA700A  
DN-01**

**OWNER'S MANUAL**

**USO E MANUTENZIONE**

**MANUAL DEL PROPIETARIO**

## **IMPORTANT INFORMATION**

- **OPERATOR AND PASSENGER**

This motorcycle is designed to carry the operator and one passenger. Never exceed the maximum weight capacity as shown on the accessories and loading label.

- **ON-ROAD USE**

This motorcycle is designed to be used only on the road.

- **READ THIS OWNER'S MANUAL CAREFULLY**

Pay special attention to the safety messages that appear throughout the manual. These messages are fully explained in the "A Few Words About Safety" section which appears before the Contents page.

This manual should be considered a permanent part of the motorcycle and should remain with the motorcycle when resold.

**Honda NSA700A  
DN-01  
OWNER'S MANUAL**

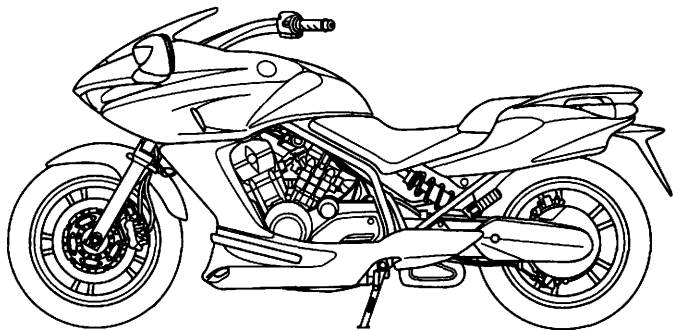

**All information in this publication is based on the latest production information available at the time of approval for printing. Honda Motor Co.,Ltd. reserves the right to make changes at any time without notice and without incurring any obligation.**

**No part of this publication may be reproduced without written permission.**

## **WELCOME**

The motorcycle presents you a challenge to master the machine, a challenge to adventure. You ride through the wind, linked to the road by a vehicle that responds to your commands as no other does. Unlike an automobile, there is no metal cage around you. Like an airplane, a pre-ride inspection and regular maintenance are essential to your safety. Your reward is freedom.

To meet the challenges safely, and to enjoy the adventure fully, you should become thoroughly familiar with this owner's manual **BEFORE YOU RIDE THE MOTORCYCLE**.

As you read this manual, you will find information that is preceded by a **NOTICE** symbol. This information is intended to help you avoid damage to your motorcycle, other property, or the environment.

When service is required, remember that your Honda dealer knows your motorcycle best. If you have the required mechanical "know-how" and tools, your dealer can supply you with an official Honda Shop Manual to help you perform many maintenance and repair tasks.

Pleasant riding, and thank you for choosing a Honda !

- The following codes in this manual indicate each country.
- The illustrations herein are based on the ED type.

E	UK
F	France
ED	European direct sales
U	Australia                  New Zealand

- The specifications may vary with each locale.

## **A FEW WORDS ABOUT SAFETY**

Your safety, and the safety of others, is very important. And operating this motorcycle safely is an important responsibility.

To help you make informed decisions about safety, we have provided operating procedures and other information on labels and in this manual. This information alerts you to potential hazards that could hurt you or others.

Of course, it is not practical or possible to warn you about all hazards associated with operating or maintaining a motorcycle. You must use your own good judgment.

You will find important safety information in a variety of forms, including:

- **Safety Labels** — on the motorcycle.
- **Safety Messages** — preceded by a safety alert symbol  and one of three signal words: **DANGER**, **WARNING**, or **CAUTION**.

These signal words mean:

**▲▲ DANGER**

**You WILL be KILLED or SERIOUSLY HURT if you don't follow instructions.**

**▲▲ WARNING**

**You CAN be KILLED or SERIOUSLY HURT if you don't follow instructions.**

**▲▲ CAUTION**

**You CAN be HURT if you don't follow instructions.**

- **Safety Headings** — such as Important Safety Reminders or Important Safety Precautions.
- **Safety Section** — such as Motorcycle Safety.
- **Instructions** — how to use this motorcycle correctly and safely.

This entire manual is filled with important safety information — please read it carefully.

# **OPERATION**

page

- 1 MOTORCYCLE SAFETY**
- 1 IMPORTANT SAFETY INFORMATION
- 2 PROTECTIVE APPAREL
- 4 LOAD LIMITS AND GUIDELINES
  
- 8 PARTS LOCATION**
- 11 INSTRUMENTS AND INDICATORS
  
- 31 MAJOR COMPONENTS**  
**(Information you need to operate this motorcycle)**
- 31 SUSPENSION
- 32 BRAKES
- 35 COOLANT
- 37 FUEL
- 40 ENGINE OIL
- 41 FINAL DRIVE OIL
- 42 TUBELESS TYRES

page

- 48 ESSENTIAL INDIVIDUAL COMPONENTS**
- 48 IGNITION SWITCH
- 49 KEYS
- 51 IMMOBILIZER SYSTEM (HISS)
- 54 RIGHT HANDLEBAR CONTROLS
- 56 LEFT HANDLEBAR CONTROLS
- 58 HAZARD WARNING SYSTEM SWITCH
- 59 HFT (Human-Friendly Transmission)

page

**69 FEATURES**

**(Not required for operation)**

- 69 STEERING LOCK
- 70 PARKING BRAKE
- 71 SEAT
- 73 HELMET HOLDER
- 74 DOCUMENT BAG
- 75 STORAGE COMPARTMENT FOR  
U-SHAPED ANTI-THEFT LOCK
- 76 RIGHT SIDE COVER
- 77 REAR COWL
- 82 UNDER COWL
- 84 FRONT COWL
- 86 HEADLIGHT AIM VERTICAL  
ADJUSTMENT
- 87 CLIP

page

**89 OPERATION**

- 89 PRE-RIDE INSPECTION
- 91 STARTING THE ENGINE
- 95 RUNNING-IN
- 96 RIDING
- 102 BRAKING
- 106 PARKING
- 107 ANTI-THEFT TIPS

# **MAINTENANCE**

page	
<b>108</b>	<b>MAINTENANCE</b>
108	THE IMPORTANCE OF MAINTENANCE
109	MAINTENANCE SAFETY
110	SAFETY PRECAUTIONS
111	MAINTENANCE SCHEDULE
114	TOOL KIT
115	SERIAL NUMBERS
116	COLOUR LABEL
117	ENGINE OIL
123	CRANKCASE BREATHER
124	SPARK PLUGS
127	FINAL DRIVE OIL
129	THROTTLE OPERATION
130	COOLANT
131	AIR CLEANER
132	FRONT AND REAR SUSPENSION INSPECTION
133	SIDE STAND
134	WHEEL REMOVAL
141	BRAKE PAD WEAR

page	
143	BATTERY
145	FUSE REPLACEMENT
149	BRAKELIGHT SWITCH ADJUSTMENT
150	BRAKE LOCK OPERATION
151	BULB REPLACEMENT
<b>160</b>	<b>CLEANING</b>
<b>165</b>	<b>STORAGE GUIDE</b>
165	STORAGE
167	REMOVAL FROM STORAGE
<b>168</b>	<b>SPECIFICATIONS</b>
<b>173</b>	<b>CATALYTIC CONVERTER</b>

# **MOTORCYCLE SAFETY**

## **IMPORTANT SAFETY INFORMATION**

Your motorcycle can provide many years of service and pleasure – if you take responsibility for your own safety and understand the challenges that you can meet on the road.

There is much that you can do to protect yourself when you ride. You'll find many helpful recommendations throughout this manual. Following are a few that we consider to be most important.

### **Always Wear a Helmet**

It's a proven fact: helmets significantly reduce the number and severity of head injuries. So always wear an approved motorcycle helmet and make sure your passenger does the same. We also recommend that you wear eye protection, sturdy boots, gloves, and other protective gear (page 2 ).

### **Make Yourself Easy to See**

Some drivers do not see motorcycles because they are not looking for them. To make yourself more visible, wear bright reflective clothing, position yourself so other drivers can see you, signal before turning or changing lanes, and use your horn when it will help others notice you.

### **Ride Within Your Limits**

Pushing the limits is another major cause of motorcycle accidents. Never ride beyond your personal abilities or faster than conditions warrant. Remember that alcohol, drugs, fatigue and inattention can significantly reduce your ability to make good judgements and ride safely.

### **Don't Drink and Ride**

Alcohol and riding don't mix. Even one drink can reduce your ability to respond to changing conditions, and your reaction time gets worse with every additional drink. So don't drink and ride, and don't let your friends drink and ride either.

### **Keep Your Bike in Safe Condition**

For safe riding, it's important to inspect your motorcycle before every ride and perform all recommended maintenance. Never exceed load limits, and only use accessories that have been approved by Honda for this motorcycle. See page 4 for more details.

### **PROTECTIVE APPAREL**

For your safety, we strongly recommend that you always wear an approved motorcycle helmet, eye protection, boots, gloves, long pants, and a long-sleeved shirt or jacket whenever you ride. Although complete protection is not possible, wearing proper gear can reduce the chance of injury when you ride.

Following are suggestions to help you choose proper gear.

### **▲ WARNING**

Not wearing a helmet increases the chance of serious injury or death in a crash.

Be sure you and your passenger always wear a helmet, eye protection and other protective apparel when you ride.

### **Helmets and Eye Protection**

Your helmet is your most important piece of riding gear because it offers the best protection against head injuries. A helmet should fit your head comfortably and securely. A bright-coloured helmet can make you more noticeable in traffic, as can reflective strips.

An open-face helmet offers some protection, but a full-face helmet offers more. Always wear a face shield or goggles to protect your eyes and help your vision.

### **Additional Riding Gear**

In addition to a helmet and eye protection, we also recommend:

- Sturdy boots with non-slip soles to help protect your feet and ankles.
- Leather gloves to keep your hands warm and help prevent blisters, cuts, burns and bruises.
- A motorcycle riding suit or jacket for comfort as well as protection. Bright-coloured and reflective clothing can help make you more noticeable in traffic. Be sure to avoid loose clothes that could get caught on any part of your motorcycle.

## **LOAD LIMITS AND GUIDELINES**

Your motorcycle has been designed to carry you and one passenger. When you carry a passenger, you may feel some difference during acceleration and braking. But so long as you keep your motorcycle well-maintained, with good tyres and brakes, you can safely carry loads within the given limits and guidelines.

However, exceeding the weight limit or carrying an unbalanced load can seriously affect your motorcycle's handling, braking and stability. Non-Honda accessories, improper modifications, and poor maintenance can also reduce your safety margin.

The following pages give more specific information on loading, accessories and modifications.

## **Loading**

How much weight you put on your motorcycle, and how you load it, are important to your safety. Anytime you ride with a passenger or cargo you should be aware of the following information.

### **WARNING**

Overloading or improper loading can cause a crash and you can be seriously hurt or killed.

Follow all load limits and other loading guidelines in this manual.

## **Load Limits**

Following are the load limits for your motorcycle:

### **Maximum weight capacity:**

164 kg (362 lbs)

Includes the weight of the rider, passenger, all cargo and all accessories

### **Maximum cargo weight:**

5 kg (11 lbs)

The weight of added accessories will reduce the maximum cargo weight you can carry.

## **Loading Guidelines**

Your motorcycle is primarily intended for transporting you and a passenger. You may wish to secure a jacket or other small items to the seat when you are not riding with a passenger.

If you wish to carry more cargo, check with your Honda dealer for advice, and be sure to read the information regarding accessories on page 7 .

Improperly loading your motorcycle can affect its stability and handling. Even if your motorcycle is properly loaded, you should ride at reduced speeds and never exceed 130 km/h (80 mph) when carrying cargo.

Follow these guidelines whenever you carry a passenger or cargo:

- Check that both tyres are properly inflated (page 42 ).
- If you change your normal load, you may need to adjust the rear suspension (page 31 ).
- To prevent loose items from creating a hazard, make sure that all cargo is securely tied down before you ride away.
- Place cargo weight as close to the center of the motorcycle as possible.
- Balance cargo weight evenly on both sides.

### **Accessories and Modifications**

Modifying your motorcycle or using non-Honda accessories can make your motorcycle unsafe. Before you consider making any modifications or adding an accessory, be sure to read the following information.

#### **⚠ WARNING**

Improper accessories or modifications can cause a crash in which you can be seriously hurt or killed.

Follow all instructions in this owner's manual regarding accessories and modifications.

## **Accessories**

We strongly recommend that you use only Honda Genuine Accessories that have been specifically designed and tested for your motorcycle. Because Honda cannot test all other accessories, you must be personally responsible for proper selection, installation and use of non-Honda accessories. Check with your dealer for assistance and always follow these guidelines:

- Make sure the accessory does not obscure any lights, reduce ground clearance and banking angle, limit suspension travel or steering travel, alter your riding position or interfere with operating any controls.
- Be sure electrical equipment does not exceed the motorcycle's electrical system capacity (page 172 ). A blown fuse can cause a loss of lights or engine power.

- Do not pull a trailer or sidecar with your motorcycle. This motorcycle was not designed for these attachments, and their use can seriously impair your motorcycle's handling.

## **Modifications**

We strongly advise you not to remove any original equipment or modify your motorcycle in any way that would change its design or operation. Such changes could seriously impair your motorcycle's handling, stability and braking, making it unsafe to ride.

Removing or modifying your lights, mufflers, emission control system or other equipment can also make your motorcycle illegal.

# PARTS LOCATION

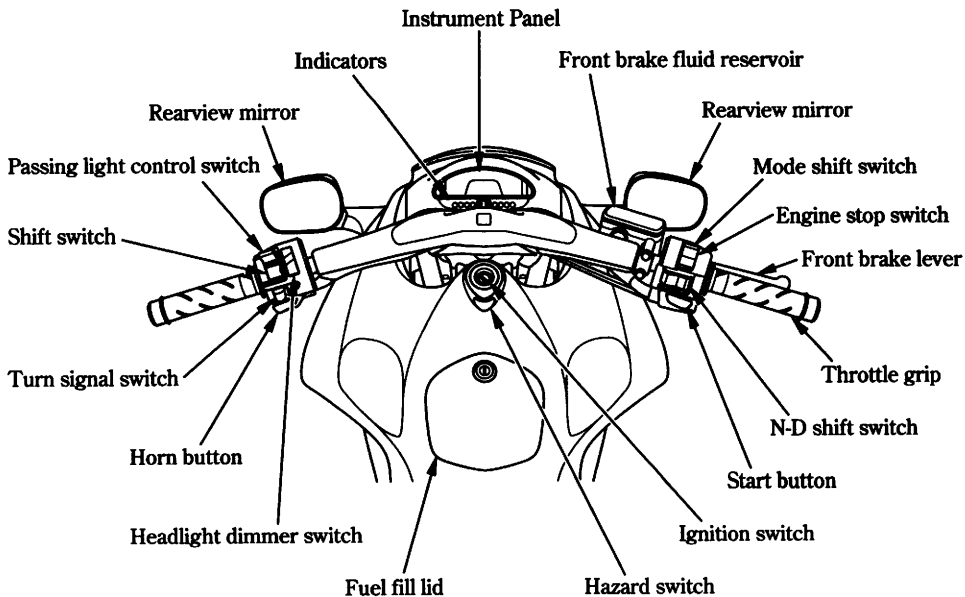

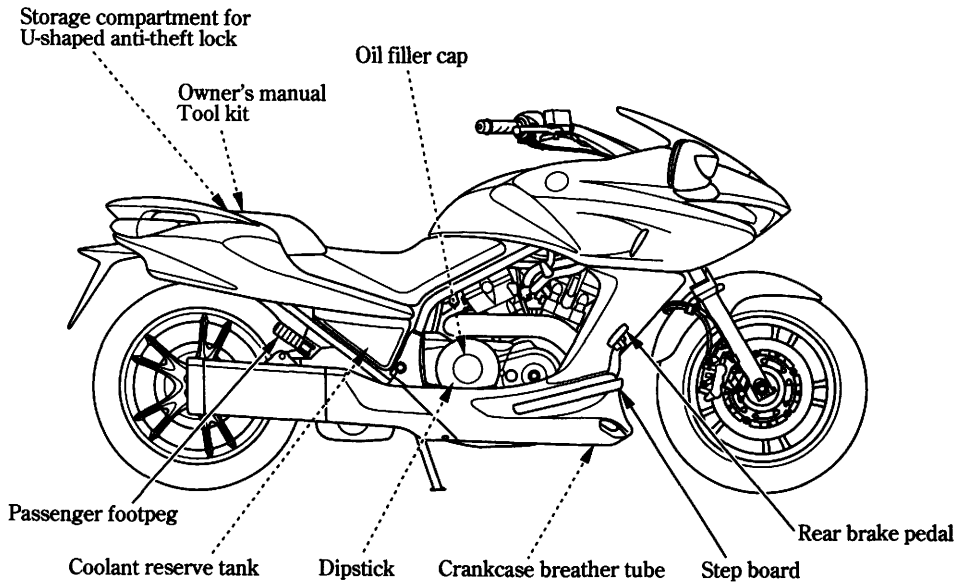

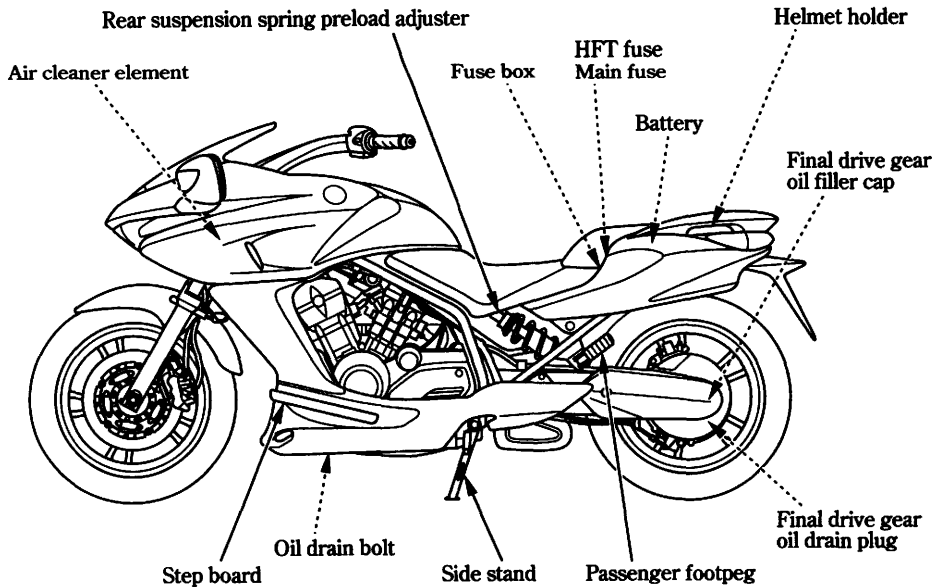

## **INSTRUMENTS AND INDICATORS**

The indicators are contained in the instrument panel. Their functions are described in the tables on the following pages.

- (1) Tachometer
- (2) Odometer/tripmeter
- (3) Speedometer
- (4) Fuel gauge
- (5) Tachometer red zone
- (6) Right turn signal indicator
- (7) Left turn signal indicator
- (8) Digital clock
- (9) Immobilizer system (HISS) indicator
- (10) High coolant temperature indicator
- (11) High beam indicator
- (12) PGM-FI malfunction indicator lamp (MIL)
- (13) Neutral indicator
- (14) Low oil level/pressure indicator
- (15) Anti-lock brake system (ABS) indicator
- (16) Parking brake indicator

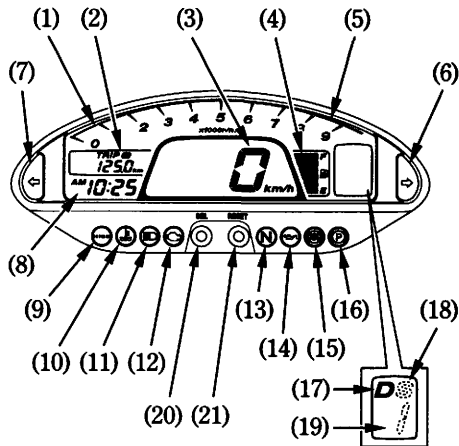

- (17) D mode indicator
- (18) S mode indicator
- (19) Shift indicator
- (20) SEL button
- (21) RESET button

<b>(Ref.No.) Description</b>	<b>Function</b>
(1) Tachometer	Shows engine revolutions per minute. This gauge shows the initial display (page 19 ).
(2) Odometer/Tripmeter	Shows odometer and tripmeter A and B. This display shows the initial display (page 19 ).
Odometer	Shows accumulated mileage (page 24 ).
Tripmeter	Shows mileage per trip (page 24 ).
(3) Speedometer	Shows riding speed. This display shows the initial display (page 19 ).
(4) Fuel gauge	Shows approximate fuel supply available (page 20 ). This gauge shows the initial display (page 19 ).

<b>(Ref.No.) Description</b>	<b>Function</b>
(5) Tachometer red zone	<p>Never allow the tachometer gauge liquid crystal display to enter the red zone, even after the engine has been broken in.</p> <p><b>NOTICE</b></p> <p>Running the engine beyond recommended maximum engine speed (the beginning of the tachometer red zone) can damage the engine.</p>
(6) Right turn signal indicator (green)	Flashes when the right turn signal operates or hazard switch operates.
(7) Left turn signal indicator (green)	Flashes when the left turn signal operates or hazard switch operates.
(8) Digital clock	<p>Shows hour and minute (page 26 ).</p> <p>This display shows the initial display (page 19 ).</p> <p>If the engine oil level can not be detected for long periods, the digital clock will change to the OIL-check display (page 29 ).</p>

<b>(Ref.No.) Description</b>	<b>Function</b>
<p>(9) Immobilizer system (HISS) indicator (red)</p>	<p>This indicator lights for a few seconds when the ignition switch is turned ON and the engine stop switch is at  (RUN). It will then go off if the properly-coded key has been inserted. If an improperly-coded key has been inserted, the indicator will remain on and the engine will not start (page 51). When the blinking function of this indicator is valid and the ignition switch is OFF, it keeps blinking for 24 hours (page 52 ).</p>
<p>(10) High coolant temperature indicator (red)</p>	<p>Lights when the coolant is over the specified temperature. Should also lights for a few seconds and then go off when the ignition switch is turned ON. If the indicator goes on while riding, stop the engine and check the reserve tank coolant level. Read pages 35 – 36 and do not ride the motorcycle until the problem has been corrected.</p> <p><b>NOTICE</b></p> <p>Exceeding maximum running temperature may cause serious engine damage.</p>

<b>(Ref.No.) Description</b>	<b>Function</b>
(11) High beam indicator (blue)	Lights when the headlight is on high beam.
(12) PGM-FI malfunction indicator lamp (MIL) (amber)	Lights when there is any abnormality in the PGM-FI (Programmed Fuel Injection) system. Should also light for a few seconds and then go off when the ignition switch is turned ON and engine stop switch is at  (RUN). If the indicator comes on at any other time, reduce speed and take the motorcycle to a Honda dealer as soon as possible.
(13) Neutral indicator (green)	Lights when the transmission is in neutral.

<b>(Ref.No.) Description</b>	<b>Function</b>
<p>(14) Low oil level/ pressure indicator (red)</p>	<p>Lights when the engine oil level is less than specified capacity or engine oil pressure is below normal operating range. Should light when ignition switch is ON and engine is not running. Should go off when the engine starts, except for occasional flickering at or near idling speed when engine is warm.</p> <p>If the indicator lights while riding, stop the engine and check the engine oil level. Read pages 22 – 23 and do not ride the motorcycle until the problem has been corrected.</p> <p><b>NOTICE</b></p> <p>Running the engine with insufficient oil level or oil pressure may cause serious damage to the engine and transmission.</p>
<p>(15) Anti-lock Brake System (ABS) indicator (amber)</p>	<p>This indicator normally comes on when the ignition switch is turned ON, and goes off after you ride the motorcycle at speed above 10 km/h (6 mph). If there is a problem with the Anti-lock Brake System, this indicator flashes and remains on (page 105).</p>

<b>(Ref.No.) Description</b>	<b>Function</b>
(16) Parking brake indicator (red)	It lights as a reminder that you have not released the parking brake.
(17) D mode indicator	Comes on when the transmission is switched from neutral to the D mode (page 62 ). Comes on when the D mode is selected in the automatic shift mode (page 64 ).
(18) S mode indicator	Comes on when the S mode is selected in the automatic shift mode (page 64 ).
(19) Shift indicator	Shows the gear position when the 6-speed manual mode is selected (page 65 ).

<b>(Ref.No.) Description</b>	<b>Function</b>
(20) SEL button	<p>Use this button for the following purposes.</p> <ul style="list-style-type: none"> <li>• To select the tripmeter A, tripmeter B or odometer (page 24 ).</li> <li>• To adjust time (page 26 )</li> <li>• To alter the blinking function of the immobilizer system (HISS) indicator (page 52 ).</li> </ul>
(21) RESET button	<p>Use this button for the following purposes.</p> <ul style="list-style-type: none"> <li>• To reset tripmeter (page 24 )</li> <li>• To change unit of speedometer, odometer and tripmeter (page 25 ) (E type only)</li> <li>• To adjust time (page 26 )</li> </ul>

### Initial Display

When the ignition switch is turned ON, the display will temporarily show all the modes and digital segments. Then, the speedometer (1) will show from 200 km/h to 0 km/h (E type: From 130 mph to 0 mph in mph), and the tachometer (2) will sweep to red zone again and go off. This is so that, you can make sure the liquid crystal display is functioning properly.

The unit "mph" (3) and "mile" (4) will be displayed for E type.

Digital clock (5) and tripmeter (6) will reset if the battery is disconnected.

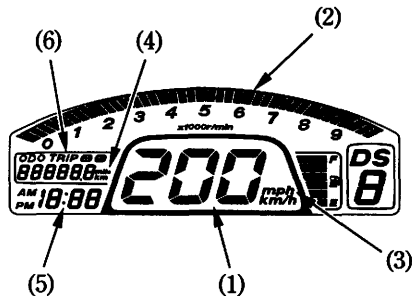

- (1) Speedometer
- (2) Tachometer
- (3) "mph"
- (4) "mile"
- (5) Digital clock
- (6) Tripmeter

## Fuel Gauge

The fuel gauge liquid crystal display (1) shows the approximate fuel supply available in a graduated display. When the segment F (2) goes on, the fuel tank capacity including reserve is:

15.0 ℓ (3.96 US gal , 3.30 Imp gal)

When segment E (3) flashes, fuel will be low and you should refill the tank as soon as possible.

The amount of fuel left in the tank with the vehicle set upright is approximately:

3.0 ℓ (0.79 US gal , 0.66 Imp gal)

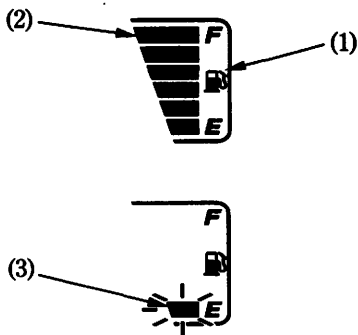

- (1) Fuel gauge liquid crystal display
- (2) Segment F
- (3) Segment E

**Fuel Gauge Failure Indication:**

When the fuel system has an error, all segments will blink.

If this occurs, see your Honda dealer as soon as possible.

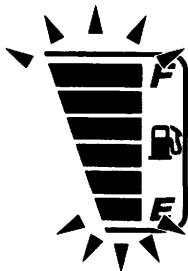

### Low Oil Level/Pressure Indicator

The low oil level/pressure indicator (1) lights when engine oil level is less than specified capacity or engine oil pressure is below the operating range.

Should light when the ignition switch is ON and the engine is not running. Should go off when the engine starts, except for occasional flickering at or near idling speed when engine is warm.

When the engine oil gets lower than specified capacity and its pressure gets low, the shift indicator also changes to the blinking “-” icon (2) along with the indicator. When this happens, the transmission automatically shifts to neutral (neutral indicator does not light).

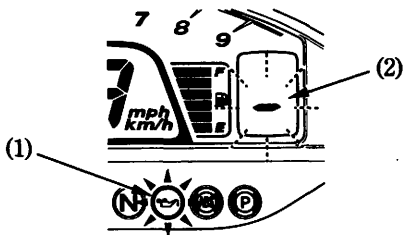

- (1) Low oil level/pressure indicator
- (2) “-” icon

If the indicator lights while the engine is running, stop the motorcycle in a safe place immediately, and check the engine oil level (page 40 ).

If the indicator stays on even if the engine oil level is not low or after more engine oil is added, contact your Honda dealer as soon as possible.

- Make sure that the motorcycle is standing upright on firm level ground when you turn ON the ignition switch. If the motorcycle is on an incline, the indicator stays on after starting the engine.

#### **NOTICE**

Running the engine with insufficient oil level or oil pressure may cause serious damage to the engine and transmission.

## Odometer/Tripmeter

The odometer (1) shows accumulated mileage.

The tripmeter shows mileage per trip. There are two tripmeters, tripmeter A (2) and tripmeter B (3).

Push the SEL button (4) to select the odometer, tripmeter A and tripmeter B.

To reset the tripmeter, push and hold the RESET button (5) when the display is in the tripmeter A or tripmeter B.

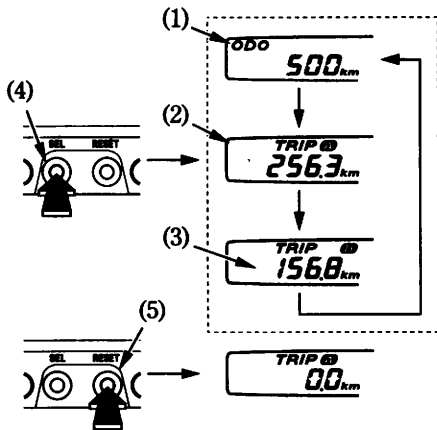

- (1) Odometer
- (2) Tripmeter A
- (3) Tripmeter B

- (4) SEL button
- (5) RESET button

## Speed and Mileage Unit Change

< E type only >

The speedometer displays both "km/h" and "mph".

The odometer/tripmeter displays both "km" and "mile".

Push and hold the RESET button (1) for more than 2 seconds to select "km/h"/"km" or "mph"/"mile" with the odometer display selected.

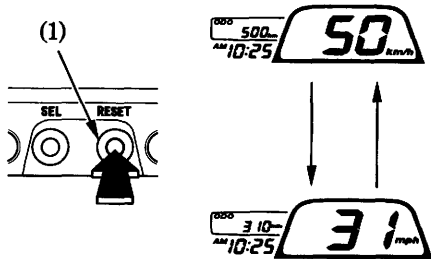

(1) RESET button

## Digital Clock

Shows hour and minute.

This motorcycle is able to detect the engine oil level. If the system can not read the engine oil level for long periods, the digital clock (1) will change to the OIL-check display (page 29).

To adjust the time, proceed as follows:

1. Turn the ignition switch ON.

2. Push and hold both the SEL button (2) and RESET button (3) for more than 2 seconds. The clock will be set in the adjust mode with the hour display flashing.

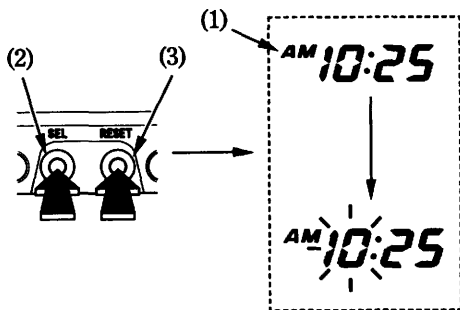

- (1) Digital clock
- (2) SEL button
- (3) RESET button

3. To set the hour, push the RESET button until the desired hour and AM/PM are displayed.

- The time is advanced by one hour, each time the button is pushed.
- The time advances fast when the button is pushed and held.

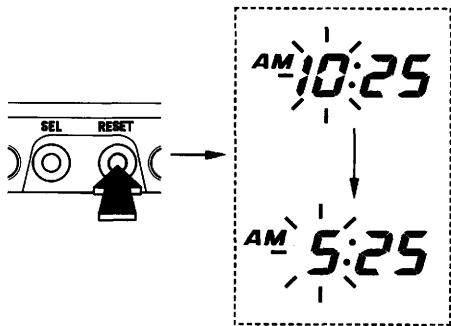

4. Push the SEL button. The minute display will start flashing.

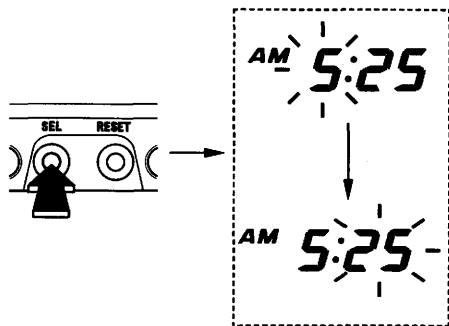

5. To set the minute, push the RESET button until the desired minute. The minute display will return to "00" when "60" is reached without affecting the hour display.

- The time advances by one minute, each time the button is pushed.
- The time advances fast when the button is pushed and held.

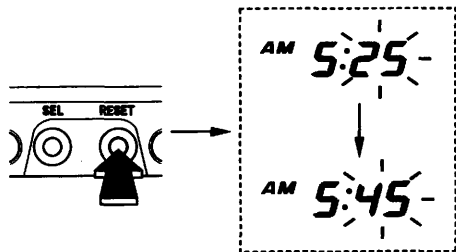

6. To end the adjustment, push the SEL button or turn the ignition switch OFF. The display will stop flashing automatically and the adjustment will be cancelled if the button is not pushed for about 2 minutes.

### OIL-Check Display:

If the ignition switch is turned ON while the motorcycle is on a slope, and it is tilted up or down to the front, back, or either side, the engine oil level may not be accurately detected. This also applies when the side stand is down and the ignition switch is ON. Before you turn the ignition switch ON, make sure to put the side stand up and place your motorcycle upright position on level ground.

If you keep riding your motorcycle for more than 2,500 km (1,553 miles) in the condition where the engine oil level cannot be detected properly, the digital clock changes to the blinking "OIL" (1) display.

If this happens, turn OFF the ignition switch, park in a safe place and check the engine oil level immediately (page 40).

If the engine oil level is low, add engine oil (page 117).

Then reset the OIL-check display (page 30).

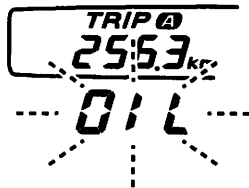

To reset OIL-check display, proceed as follows:

After 4–5 minutes from stopping the engine, put the side stand up with the motorcycle upright on firm, level ground, and turn the ignition switch ON. Make sure that the digital clock is displayed.

When the OIL-check display still does not return to the digital clock, contact your Honda dealer immediately.

## MAJOR COMPONENTS

### (Information you need to operate this motorcycle)

#### SUSPENSION

The shock absorber (1) has 7 adjustment positions for different load or riding conditions.

Use a pin spanner (2) and extension bar (3) to adjust the rear shocks.

Always adjust the shock absorber position in sequence (1-2-3-4-5-6-7 or 7-6-5-4-3-2-1).

Attempting to adjust directly from 1 to 7 or 7 to 1 may damage the shock absorber.

Position 1 is for light loads and smooth road conditions. Positions 3 to 7 increase spring preload for a stiffer rear suspension, and can be used when the motorcycle is heavily loaded.

Standard position: 2

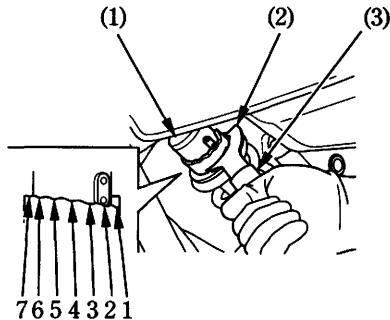

- (1) Shock absorber
- (2) Pin spanner
- (3) Extension bar

## **BRAKES**

Both the front and rear brakes are the hydraulic disc types.

As the brake pads wear, the brake fluid level drops.

There are no adjustments to perform, but fluid level and pad wear must be inspected periodically. The system must be inspected frequently to ensure there are no fluid leaks. If the brake lever or pedal free travel becomes excessive and the brake pads are not worn beyond the recommended limit (page 141 ), there is probably air in the brake system and it must be bled. See your Honda dealer for this service.

### Front Brake Fluid Level:

With the motorcycle in an upright position, check the fluid level. It should be above the LOWER level mark (1). If the level is at or below the LOWER level mark, check the brake pads for wear (page 141 ).

Worn pads should be replaced. If the pads are not worn, have your brake system inspected for leaks.

The recommended brake fluid is Honda DOT 4 brake fluid from a sealed container, or an equivalent.

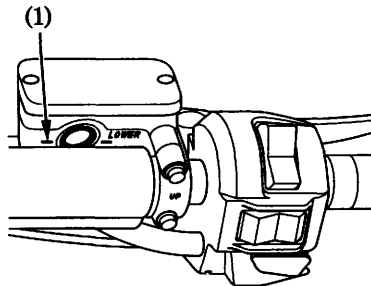

(1) LOWER level mark

### Front Brake Lever:

The distance between the tip of the brake lever (1) and the grip can be adjusted by turning the adjuster dial (2) while pushing the lever forward.

Align the numbers (3) on the adjuster dial with the index mark (4).

Apply the brake several times and check for free wheel rotation after the brake lever is released.

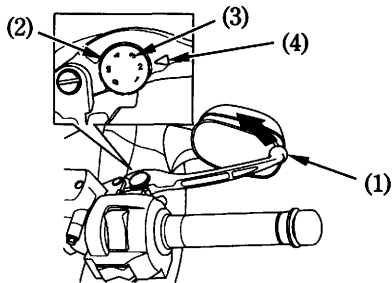

(1) Brake lever  
(2) Adjuster dial

(3) Numbers  
(4) Index mark

### Other Checks:

Make sure there are no fluid leaks. Check for deterioration or cracks in the hoses and fittings.

### Rear Brake Fluid Level:

With the motorcycle in an upright position, check the fluid level. It should be between the UPPER (1) and LOWER (2) level marks. If the level is at or below the LOWER level mark, check the rear brake pads for wear (page 142 ).

Worn pads should be replaced. If the pads are not worn, have your brake system inspected for leaks.

The recommended brake fluid is Honda DOT 4 brake fluid from a sealed container, or an equivalent.

### Other Checks:

Make sure there are no fluid leaks. Check for deterioration or cracks in the hoses and fittings.

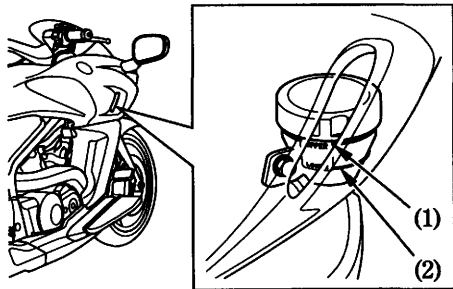

- (1) UPPER level mark
- (2) LOWER level mark

## **COOLANT**

### **Coolant Recommendation**

The owner must properly maintain the coolant to prevent freezing, overheating, and corrosion. Use only high quality ethylene glycol antifreeze containing corrosion protection inhibitors specifically recommended for use in aluminum engines. (SEE ANTIFREEZE CONTAINER LABEL).

Use only low-mineral drinking water or distilled water as a part of the antifreeze solution. Water that is high in mineral content or salt may be harmful to the aluminum engine.

Using coolant with silicate inhibitors may cause premature wear of water pump seals or blockage of radiator passages.

Using tap water may cause engine damage.

The factory provides a 50/50 solution of antifreeze and distilled water in this motorcycle. This coolant solution is recommended for most operating temperatures and provides good corrosion protection. A higher concentration of antifreeze decreases the cooling system performance and is recommended only when additional protection against freezing is needed. A concentration of less than 40/60 (40% antifreeze) will not provide proper corrosion protection. During freezing temperatures, check the cooling system frequently and add higher concentrations of antifreeze (up to a maximum of 60% antifreeze) if required.

## Inspection

The reserve tank is behind the frame.

Check the coolant level in the reserve tank (1) while the engine is at the normal operating temperature with the motorcycle in an upright position. If the coolant level is below the LOWER level mark (2), remove the right rear cowl (page 77) and the reserve tank cap (3).

Add coolant mixture until it reaches the UPPER level mark (4). Always add coolant to the reserve tank.

Do not attempt to add coolant by removing the radiator cap.

If the reserve tank is empty, or if coolant loss is excessive, check for leaks and see your Honda dealer for repair.

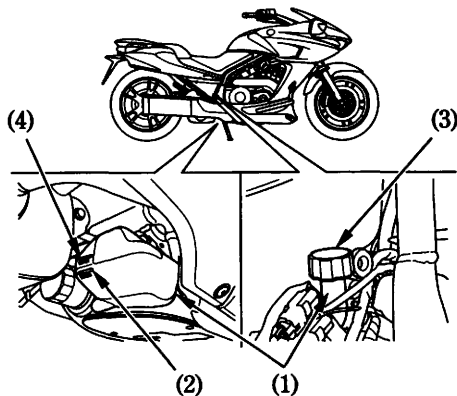

- (1) Reserve tank
- (2) LOWER level mark
- (3) Reserve tank cap
- (4) UPPER level mark

## FUEL

### Fuel Tank

The fuel tank capacity including the reserve supply is:

15.0 ℓ (3.96 US gal , 3.30 Imp gal)

To open the fuel fill cap (1), insert the ignition key (2) and turn it clockwise to open the fuel fill lid (3). Turn the fuel fill cap counterclockwise to remove it.

Do not overfill the tank. There should be no fuel in the filler neck (4).

After refueling, be sure to tighten the fuel fill cap firmly by turning it clockwise until it clicks.

Close the fuel fill lid.

Remove the key from the fuel fill lid.

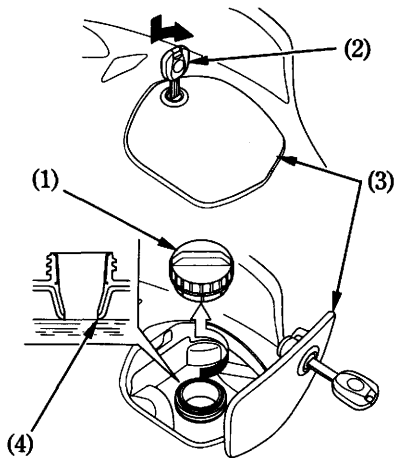

(1) Fuel fill cap  
(2) Ignition key

(3) Fuel fill lid  
(4) Filler neck

## **WARNING**

Petrol is highly flammable and explosive. You can be burned or seriously injured when handling fuel.

- Stop the engine and keep heat, sparks, and flame away.
- Refuel only outdoors.
- Wipe up spills immediately.

Use unleaded petrol with a research octane number of 91 or higher.

The use of leaded petrol will cause premature damage to the catalytic converter.

### **NOTICE**

If “spark knock” or “pinking” occurs at a steady engine speed under normal load, change brands of petrol. If spark knock or pinking persists, consult your Honda dealer. Failure to do so is considered misuse, and damage caused by misuse is not covered by Honda's Limited Warranty.

### **Petrol Containing Alcohol**

If you decide to use a petrol containing alcohol (gasohol), be sure it's octane rating is at least as high as that recommended by Honda. There are two types of "gasohol": one containing ethanol, and the other containing methanol. Do not use petrol that contains more than 10 % ethanol. Do not use petrol containing methanol (methyl or wood alcohol) that does not also contain cosolvents and corrosion inhibitors for methanol. Never use petrol containing more than 5 % methanol, even if it has cosolvents and corrosion inhibitors.

Fuel system damage or engine performance problems resulting from the use of fuels that contain alcohol is not covered under the warranty. Honda cannot endorse the use of fuels containing methanol since evidence of their suitability is as yet incomplete.

Before buying fuel from an unfamiliar station, try to find out if the fuel contains alcohol. If it does, confirm the type and percentage of alcohol used. If you notice any undesirable operating symptoms while using a petrol that contains alcohol, or one that you think contains alcohol, switch to a petrol that you know does not contain alcohol.

## ENGINE OIL

### Engine Oil Level Check

Check the engine oil level each day before riding the motorcycle.

The level must be maintained between the upper (1) and lower (2) level marks on the dipstick (3).

Immediately after stopping the engine, the engine, exhaust pipe and muffler are too hot. Be careful not to burn yourself.

1. Remove the right side cover (page 76 ).
2. Start the engine and let it idle for 3–5 minutes. Make sure the low oil level/pressure indicator goes off. If the indicator remains on, stop the engine immediately.
3. Stop the engine and hold the motorcycle in an upright position on firm, level ground.
4. After 2–3 minutes, remove the dipstick, wipe it clean, and reinsert the dipstick without screwing it in. Remove the dipstick. The oil level should be between the upper and lower marks on the

dipstick.

5. If required, remove the oil filler cap (4) and add the specified oil (page 117) up to the upper level mark. Do not overfill.
6. Reinstall the dipstick and oil filler cap. Check for oil leaks.
7. Install the right side cover (page 76 ).

### NOTICE

Running the engine with insufficient oil level or oil pressure may cause serious damage to the engine and transmission.

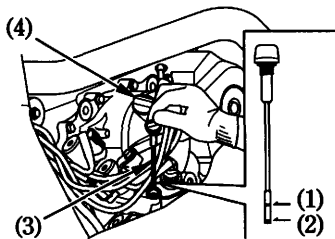

- |                      |                    |
|----------------------|--------------------|
| (1) Upper level mark | (3) Dipstick       |
| (2) Lower level mark | (4) Oil filler cap |

## FINAL DRIVE OIL

### Oil Level Check

Check the final drive oil level when specified by the maintenance schedule (page 113).

1. Place the motorcycle on its side stand.
2. Remove bolt A (1), bolt B (2) and washer.
3. Pull out the prong (3) from the grommet (4), and remove the final gear cover (5).

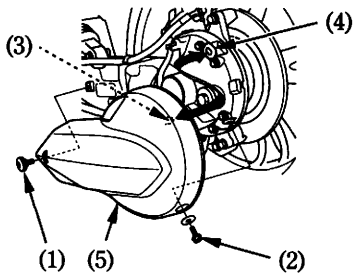

- (1) Bolt A  
(2) Bolt B  
(3) Prong  
(4) Grommet  
(5) Final gear cover

4. Remove the oil filler cap (6).
5. Check that the oil level reaches the lower edge of the oil filler inspection hole (7).

If the level is low, check for leaks. Pour fresh oil through the oil filler inspection hole until it reaches the lower edge of the opening.

### Recommended Oil: HYPOID GEAR OIL SAE 80

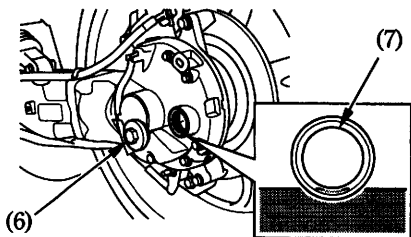

- (6) Oil filler cap      (7) Oil filler inspection hole

## **TUBELESS TYRES**

To safely operate your motorcycle, your tyres must be the proper type and size, in good condition with adequate tread, and correctly inflated for the load you are carrying. The following pages give more detailed information on how and when to check your air pressure, how to inspect your tyres for damage, and what to do when your tyres need to be repaired or replaced.

### **▲ WARNING**

Using tyres that are excessively worn or improperly inflated can cause a crash in which you can be seriously hurt or killed.

Follow all instructions in this owner's manual regarding tyre inflation and maintenance.

## **Air Pressure**

Keeping your tyres properly inflated provides the best combination of handling, tread life and riding comfort. Generally, underinflated tyres wear unevenly, adversely affect handling, and are more likely to fail from being overheated.

Overinflated tyres make your motorcycle ride harshly, are more prone to damage from road hazards, and wear unevenly.

We recommend that you visually check your tyres before every ride and use a gauge to measure air pressure at least once a month or any time you think the tyres might be low.

Tubeless tyres have some self-sealing ability if they are punctured. However, because leakage is often very slow, you should look closely for punctures whenever a tyre is not fully inflated.

Always check air pressure when your tyres are “cold” – when the motorcycle has been parked for at least three hours. If you check air pressure when your tyres are “warm” – when the motorcycle has been ridden for even a few miles – the readings will be higher than if the tyres were “cold”. This is normal, so do not let air out of the tyres to match the recommended cold air pressures given below. If you do, the tyres will be underinflated.

The recommended “cold” tyre pressures are:

Front	225 kPa (2.25 kgf/cm <sup>2</sup> , 33 psi)
Rear	250 kPa (2.50 kgf/cm <sup>2</sup> , 36 psi)

### Inspection

Whenever you check the tyre pressures, you should also examine the tyre treads and sidewalls for wear, damage, and foreign objects:

Look for:

- Bumps or bulges in the side of the tyre or the tread. Replace the tyre if you find any bumps or bulges.
- Cuts, splits or cracks in the tyre. Replace the tyre if you can see fabric or cord.
- Excessive tread wear.

Also, if you hit a pothole or hard object, pull to the side of the road as soon as you can safely and carefully inspect the tyres for damage.

## Tread Wear

Replace tyres before tread depth at the center of the tyre reaches the following limit:

Minimum tread depth	
Front:	1.5 mm (0.06 in)
Rear:	2.0 mm (0.08 in)

< For Germany >

German law prohibits use of tyres whose tread depth is less than 1.6 mm.

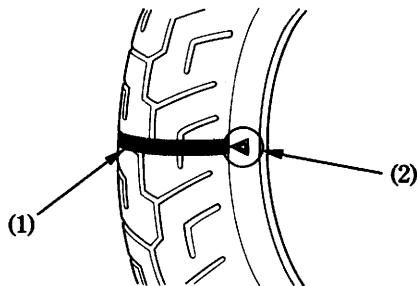

- (1) Wear indicator
- (2) Wear indicator location mark

## **Tyre Repair**

If a tyre is punctured or damaged, you should replace it, not repair it. As discussed below, a tyre that is repaired, either temporarily or permanently, will have lower speed and performance limits than a new tyre.

A temporary repair, such as an external tubeless tyre plug, may not be safe for normal speeds and riding conditions. If a temporary or emergency repair is made to a tyre, you should ride slowly and cautiously to a dealer and have the tyre replaced. If possible, you should not carry a passenger or cargo until a new tyre is installed.

Even if a tyre is professionally repaired with a permanent internal patch plug, it will not be as good as a new tyre. You should not exceed 80 km/h (50 mph) for the first 24 hours, or 130 km/h (80 mph) at any time thereafter. In addition, you may not be able to safely carry as much weight as with a new tyre. Therefore, we strongly recommend that you replace a damaged tyre. If you choose to have a tyre repaired, be sure the wheel is balanced before you ride.

## **Tyre Replacement**

The tyres that came on your motorcycle were designed to match the performance capabilities of your motorcycle and provide the best combination of handling, braking, durability and comfort.

### **⚠ WARNING**

Installing improper tyres on your motorcycle can affect handling and stability. This can cause a crash in which you can be seriously hurt or killed.

Always use the size and type of tyres recommended in this owner's manual.

The recommended tyres for your motorcycle are:

Front: 130/70ZR17M/C (62W)  
DUNLOP  
ROADSMART CQ  
BRIDGESTONE  
BT021F G

Rear: 190/50ZR17M/C (73W)  
DUNLOP  
ROADSMART K  
BRIDGESTONE  
BT021R G

Type: radial-ply, tubeless

Whenever you replace a tyre, use one that is equivalent to the original and be sure the wheel is balanced after the new tyre is installed.

### **Important Safety Reminders**

- Do not install a tube inside a tubeless tyre on this motorcycle. Excessive heat build-up can cause the tube to burst.
- Use only tubeless tyres on this motorcycle. The rims are designed for tubeless tyres, and during hard acceleration or braking, a tube-type tyre could slip on the rim and cause the tyre to rapidly deflate.

## ESSENTIAL INDIVIDUAL COMPONENTS

### IGNITION SWITCH

The ignition switch (1) is below the steering stem.

The headlight, position light (except U type), taillight and license light will come on whenever you turn the ignition switch ON. If your motorcycle is stopped with the ignition switch ON and the engine is not running, the headlight, position light (except U type), taillight and license light will still be on, resulting in battery discharge.

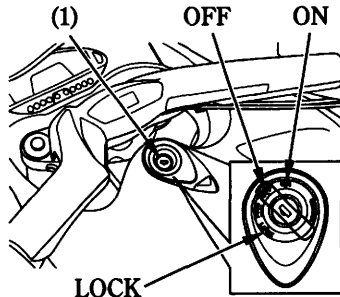

(1) Ignition switch

Key Position	Function	Key Removal
LOCK (steering lock)	Steering is locked. Engine and lights cannot be operated.	Key can be removed
OFF	Engine and lights cannot be operated.	Key can be removed
ON	Engine and lights can be operated.	Key cannot be removed

## KEYS

This motorcycle has two keys and a key number plate.

You will need the key number if you ever have to replace a key. Store the plate in a safe place.

To reproduce keys, bring all keys, key number plate and motorcycle to your Honda dealer.

Up to four keys can be registered with the immobilizer system (HISS), including the ones in hand.

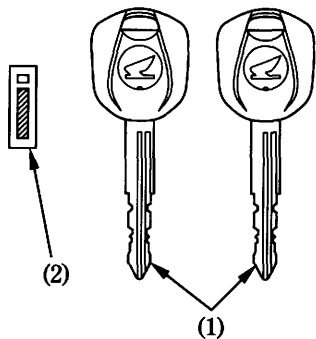

(1) Keys

(2) Key number plate

If all keys are lost, the PGM-FI unit/ignition control module must be replaced. To avoid this possibility we recommend that if only one key is left, you immediately have it reproduced to ensure that a back-up is available.

These keys contain electronic circuits that are activated by the immobilizer system (HISS). They will not work to start the engine if the circuits are damaged.

- Do not drop the keys or set heavy objects on them.
- Do not grind, drill or in any way alter the original shape of the keys.
- Keep the keys away from magnetic objects.

### **IMMOBILIZER SYSTEM (HISS)**

HISS is the abbreviation of Honda Ignition Security System.

The immobilizer system (HISS) protects your motorcycle from theft. A properly-coded key must be used in the ignition switch for the engine to start. If an improperly-coded key (or other device) is used the engine's starting circuit is disabled.

When the ignition switch is turned ON and the engine stop switch is at " O " (RUN), the immobilizer system (HISS) indicator lights for a few seconds, then goes off. If the indicator remains on, it means the system does not recognize the coding of the key. Turn the ignition switch to OFF, remove the key, reinsert and turn the switch ON again.

The immobilizer system has such a function that keeps the immobilizer system (HISS) indicator blinking at 2 second intervals for 24 hours. This blinking function can be turned on or off.

This function will turn on if the battery is disconnected.

To alter the blinking function:

1. Turn the ignition switch ON.
2. Push and hold the SEL button (1) for more than 2 seconds.  
The immobilizer system (HISS) indicator (2) instantly flashes, the function is enabled.
3. Turn the ignition switch OFF and remove the key.

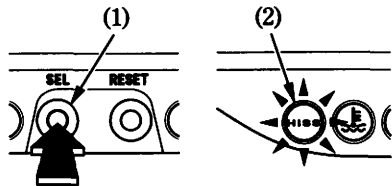

- (1) SEL button  
(2) Immobilizer system (HISS) indicator

If the system repeatedly does not recognize the coding of your key, contact your Honda dealer.

- The system may not recognize the key's coding if any other immobilizer key is near the ignition switch. To make sure the system recognizes the key code, keep each immobilizer key on a separate ring.
- Do not attempt to alter the immobilizer system (HISS) or add other devices to it. Electrical problems could result, making it impossible to start your motorcycle.
- If all keys are lost, the PGM-FI unit/ignition control module must be replaced.

### EC Directives

This immobilizer system complies with the R & TTE (Radio equipment and telecommunications terminal equipment and the mutual recognition of their conformity) Directive.



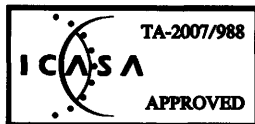

The declaration of conformity to R & TTE Directive is provided to the owner at the time of purchase. The declaration of conformity should be kept at a safe place. When the declaration of conformity is lost or is not provided, contact your Honda dealer.

< South Africa only >



## RIGHT HANDLEBAR CONTROLS

### Engine Stop Switch

The engine stop switch (1) is next to the throttle grip. When the switch is in the  (RUN) position, the engine will operate. When the switch is in the  (OFF) position, the engine will not operate. This switch is intended primarily as a safety or emergency switch and should normally remain in the  (RUN) position.

If your motorcycle is stopped with the ignition switch ON and the engine stop switch  (OFF), the headlight, position light (except U type), taillight and license light will still be on, resulting in battery discharge.

### Start Button

The start button (2) is next to the throttle grip.

The start button is used for starting the engine. Pushing the button in starts the engine. See Starting Procedure, page 94 .

When the start button is pushed, the starter motor will crank the engine and the headlight will automatically go out, but the position light (except U type), taillight and license light will stay on.

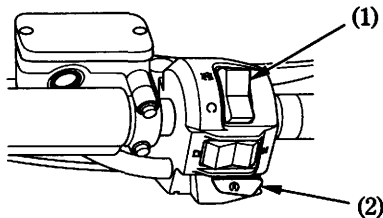

- (1) Engine stop switch
- (2) Start button

### **N-D Shift Switch**

The N-D shift switch (3) is below the engine stop switch.

The switch has two positions: drive (D) and neutral (N).

See pages 60 – 63 for operation of the switch to ride your motorcycle.

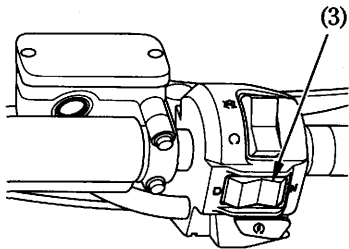

(3) N-D shift switch

### **Mode Shift Switch**

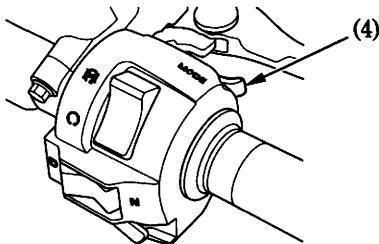

To shift between the automatic shift mode and 6-speed manual mode, press the mode shift switch (4).



(4) Mode shift switch

## LEFT HANDLEBAR CONTROLS

### Headlight Dimmer Switch (1)

Move the headlight dimmer switch to  (HI) to select high beam or to  (LO) to select low beam.

### Passing Light Control Switch (2)

When this switch is pressed, the headlight flashes on to signal approaching cars or when passing.

### Turn Signal Switch (3)

Move to  to signal a left turn,  to signal a right turn. Press to turn signal off.

### Horn Button (4)

Press the button to sound the horn.

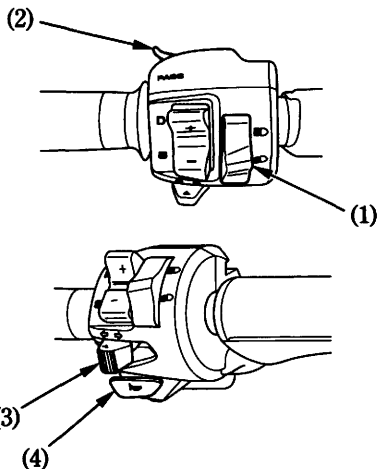

- (1) Headlight dimmer switch
- (2) Passing light control switch
- (3) Turn signal switch
- (4) Horn button

### **Shift Switch (5)**

When the Automatic Shift Mode is selected:

Press the shift switch to select the D mode or S mode.

When the 6-speed Manual Mode is selected:

Press the shift switch to shift the gear between 1st and 6th.

Shift switch (+) (6):

- Automatic shift mode: select the D mode.
- 6-speed manual mode: shift up.

Shift switch (-) (7):

- Automatic shift mode: select the S mode.
- 6-speed manual mode: shift down.

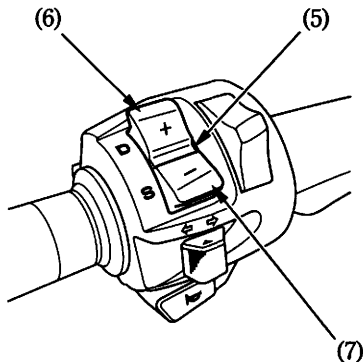

- (5) Shift switch
- (6) Shift switch (+)
- (7) Shift switch (-)

## HAZARD WARNING SYSTEM SWITCH

The Hazard should be used only when your motorcycle is stopped under emergency or hazardous conditions. To turn it on, turn the ignition key to the ON position, and then push the switch marked . The front and rear turn signals will blink simultaneously.

All of the signals can blink without the ignition key.

To operate this function, proceed as follows:

1. Turn the ignition key to ON position and then push the hazard switch (1).
2. All of the turn signals will keep blinking even after you turn the ignition key to OFF position.
3. You can turn off the turn blinking signals by pushing the hazard switch back to the off position.

If the switch is off position for more than two seconds, and then push the switch again, the turn signals will not be on.

Be sure to turn the switch off when the hazard warning is no longer required, or the turn signals will not work properly, and may confuse other drivers.

If all the turn signals are left blinking with the engine stopped, the battery will be discharged.

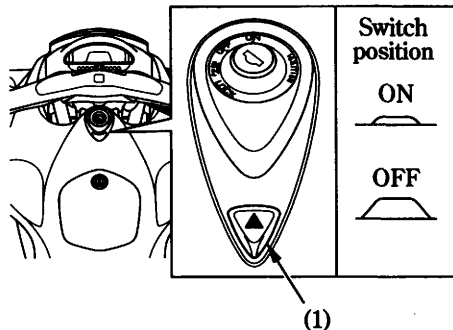

(1) Hazard switch

### **HFT (Human-Friendly Transmission)**

HFT is a hydraulic mechanical automatic transmission. It is a computerized control system with neutral and two selectable modes, automatic shift mode and 6-speed manual mode.

Automatic shift mode has two options; D mode and S mode.

#### Neutral:

Under the following conditions, the driving force does not transmit.

- The ignition switch is ON and engine is not running.
- Until you operate the N-D shift switch to select D mode after the engine starts.

### Automatic Shift Mode:

In this mode you can shift automatically between low speed and high speed depending on the throttle opening and the vehicle speed. D mode and S mode can be selected.

#### D Mode:

This is the basic mode of the automatic shift mode.

Select for normal riding.

#### S Mode:

Select when you need driving force (when you are going up a steep hill, or stop-and-go riding or riding with a passenger).

Enable for powerful riding.

### 6-speed Manual Mode:

In this mode, the rider can shift up and down manually in six-stages with the use of the shift switch. For sporty riding.

To switch modes between neutral and each drive mode, use the switches of the right and left handlebars as shown in the illustration. Refer to following pages for more information.

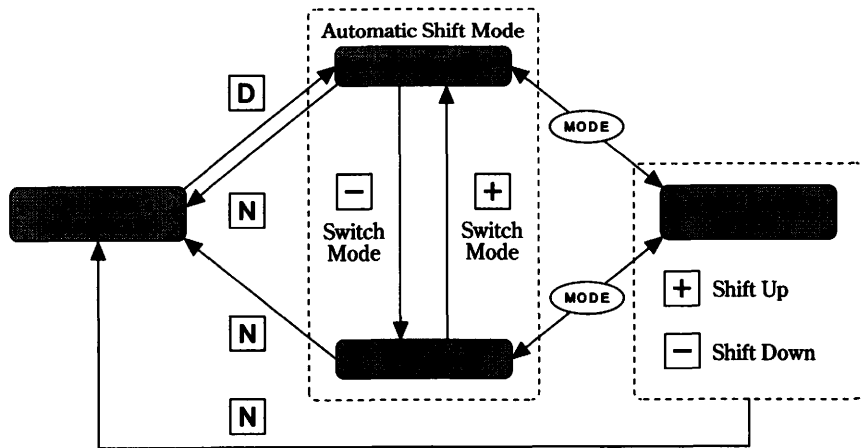

**D** : N-D shift switch (D)

**MODE** : Mode shift switch

**+** : Shift switch (+)

**N** : N-D shift switch (N)

**-** : Shift switch (-)

### **Switching Between Neutral and Automatic Shift Mode or 6-speed Manual Mode**

When you operate the N-D shift switch (1), make sure as follows:

- Your motorcycle is stopped.
  - The engine is running.
  - The throttle is fully closed.
- If the throttle is opened while switching the HFT between neutral and the D mode, the engine will stop.

The HFT can only be switched between neutral and the D mode when idling.

To switch the transmission into D mode:

Press and hold the D (drive) side (2) of the N-D shift switch until the neutral indicator (3) turns off and the D mode indicator (4) comes on.

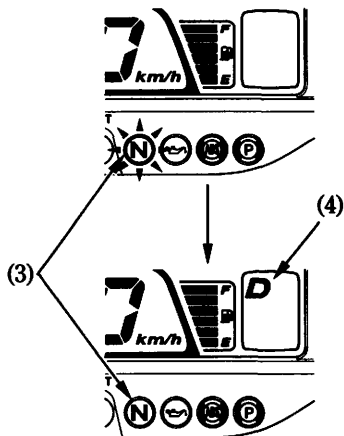
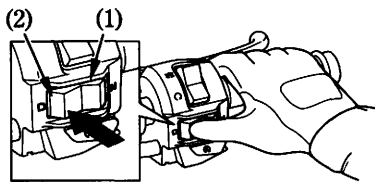

- (1) N-D shift switch
- (2) N-D shift switch (D)

- (3) Neutral indicator
- (4) D mode indicator

**To switch the transmission into neutral:**

Press and hold the N (neutral) side (1) of the N-D shift switch in each drive mode until the D mode indicator (2), S mode indicator (3) or shift indicator (4) disappears and the neutral indicator (5) turns on.

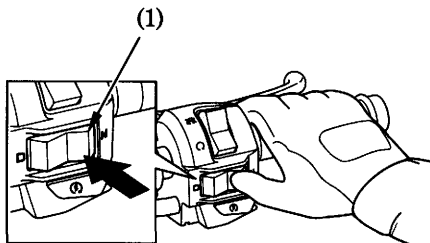

(1) N-D shift switch (N)

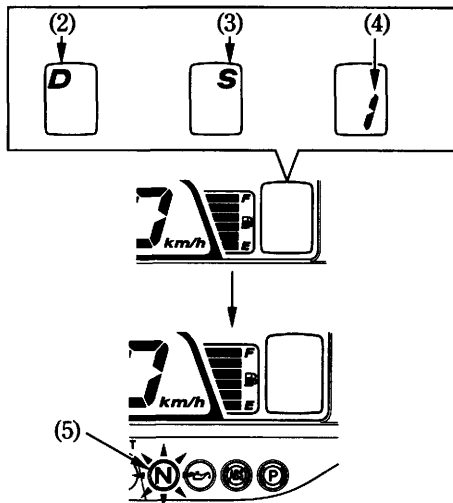

(2) D mode indicator  
(3) S mode indicator

(4) Shift indicator  
(5) Neutral indicator

### **Switching D Mode and S Mode When the Automatic Shift Mode Is Selected**

Press the shift switch (1) to change the D mode and the S mode while the automatic shift mode is selected.

#### Switching D mode to S mode:

Press the shift switch (-) (2) to switch to the S mode and the S mode indicator (3) comes on.

#### Switching S mode to D mode:

Press the shift switch (+) (4) to switch to the D mode and the D mode indicator (5) comes on.

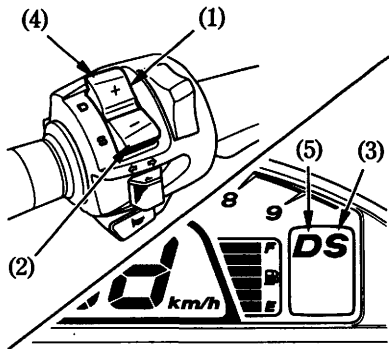

(1) Shift switch

(2) Shift switch (-)

(3) S mode indicator

(4) Shift switch (+)

(5) D mode indicator

## **Switching Between Automatic Shift Mode and 6-speed Manual Mode**

### **Switching Automatic Shift Mode to 6-speed Manual Mode:**

Press the mode shift switch (1). The shift indicator (2) appears in the instrument panel to show the selected gear position. When switching automatic shift mode to 6-speed manual mode, the gear is switched to the suitable position.

- When switching automatic shift mode to 6-speed manual mode, the engine rev will fluctuate for selecting the suitable gear position for the speed.

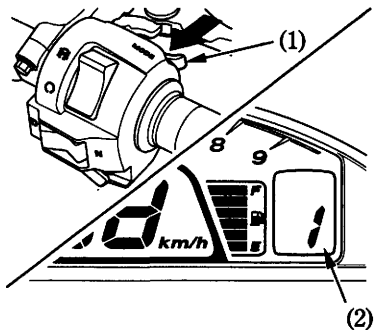

(1) Mode shift switch

(2) Shift indicator

### Switching 6-speed Manual Mode to Automatic Shift Mode:

Press the mode shift switch (1). The shift indicator (4) goes off and the D mode indicator (2) or S mode indicator (3) appears. When switching 6-speed manual mode to automatic shift mode, the drive mode changes depending on the last selection.

- If you press and hold the mode shift switch, the 6-speed manual mode switching can not be done.

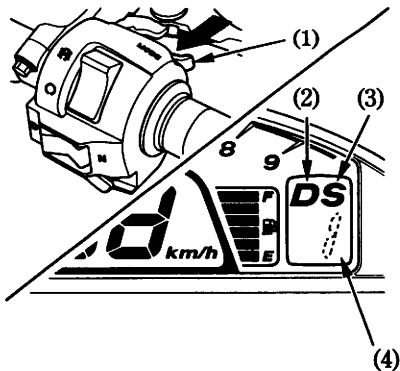

- (1) Mode shift switch
- (2) D mode indicator
- (3) S mode indicator
- (4) Shift indicator

## Shifting When the 6-speed Manual Mode Is Selected

Press the shift switch to shift gears when the 6-speed manual mode is selected. The shift indicator (1) shows the gear position.

When the 6-speed manual mode is selected, shifting is not automatic. Shift so as not to let the engine rev enter the red zone.

To upshift transmission, press the shift switch (+) (2) once.

To downshift transmission, press the shift switch (-) (3) once.

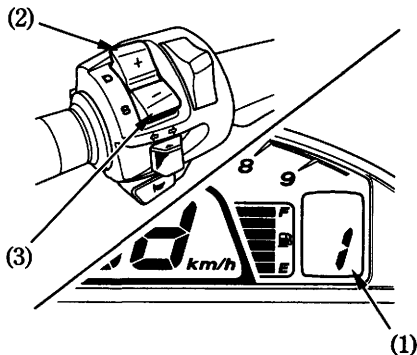

- (1) Shift indicator
- (2) Shift switch (+)
- (3) Shift switch (-)

### Shifting Restriction:

If the travel-device will be damaged or there will be over revving of the engine while shifting, shifting can not be done.

- Operating the shift switch (+) or (-) once changes one gear. The sequential shifting cannot be done if the shift switch (+) or (-) is pressed and held. If changing gear continuously, take your finger off the shift switch (+) or (-) and then press the shift switch (+) or (-) again.
- If your speed becomes too slow in the 6-speed manual mode, it shifts down automatically.

### **If There Is a Failure In HFT**

If switching D mode and S mode cannot be done in the automatic shift mode or shifting cannot be done in the 6-speed manual mode, “-” icon (1) flashes to indicate a failure in HFT. See your Honda dealer as soon as possible.

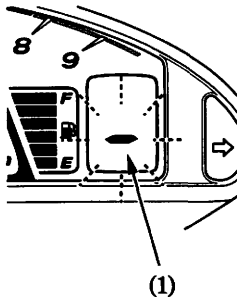

(1) “-” icon

## FEATURES

### (Not required for operation)

#### STEERING LOCK

To lock the steering, turn the handlebar all the way to the left, turn the ignition key (1) to LOCK while pushing in. Remove the key. To unlock the steering, turn the key to OFF while pushing in.

Do not turn the key to LOCK while riding the motorcycle; loss of vehicle control will result.

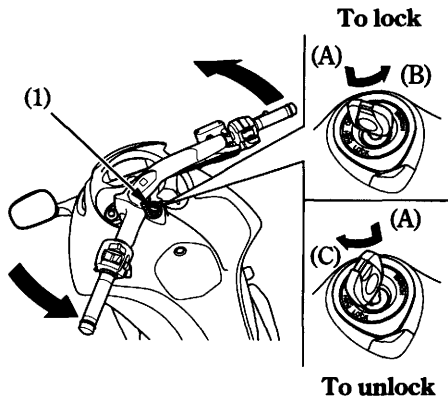

(1) Ignition key

(A) Push in  
(B) Turn to LOCK  
(C) Turn to OFF

## **PARKING BRAKE**

The motorcycle is equipped with a parking brake.

### To Apply the Parking Brake:

Pull in the parking brake lever (1) to lock the rear wheel.

### To Release the Parking Brake:

Release the parking brake lever while lightly pulling in the lever.

Before riding, check that the parking brake indicator is turned OFF and make sure that the rear brake is fully released so there is no drag on the rear wheel.

### **To apply**

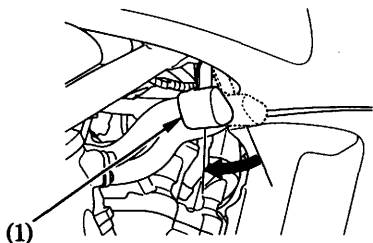

### **To release**

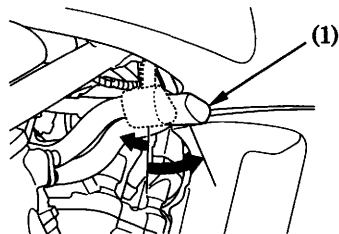

(1) Parking brake lever

## SEAT

### Rear seat

To remove the rear seat (1), insert the ignition key (2) into the seat lock (3) below the left side of the seat. Turn it clockwise, then pull the rear seat up and back.

To install the seat, insert the seat prongs (4) into the seat hooks (5) and insert the frame prongs (6) into the guide hooks (7). Thereafter, push down on the rear of the seat.

Be sure the seat is locked securely in position after installation.

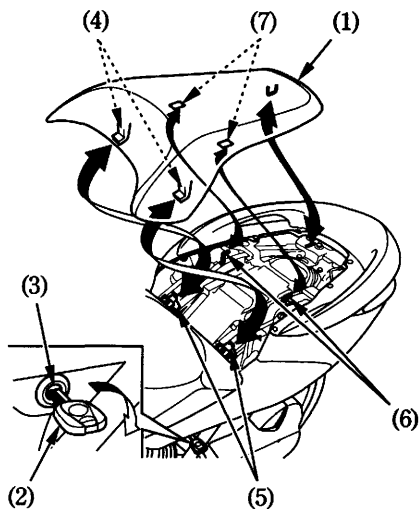

- (1) Rear seat
- (2) Ignition key
- (3) Seat lock
- (4) Seat prongs

- (5) Seat hooks
- (6) Frame prongs
- (7) Guide hooks

### Front seat

To remove the front seat (1), remove the rear seat (page 71 ) and mounting bolts (2), and then pull the seat back and up.

To install the seat, insert the front tabs (3) into the recesses and the rear tabs (4) into the rear stay (5) on the frame, and tighten the mounting bolts securely. Install the rear seat.

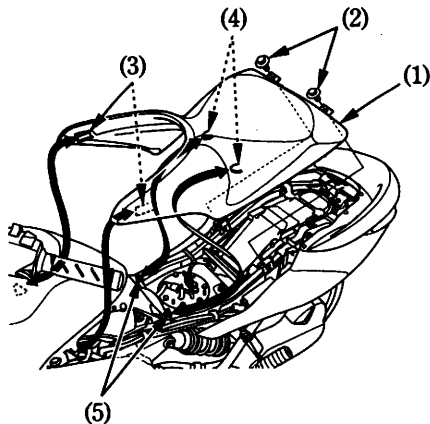

- (1) Front seat
- (2) Mounting bolts
- (3) Front tabs

- (4) Rear tabs
- (5) Rear stay

## HELMET HOLDER

The helmet holder is located below the rear seat.

Remove the rear seat (page 71 ). Route the helmet wire (1) through the helmet D-ring (2) and hook the loops of the helmet wire onto the helmet holder (3).

Install the rear seat and lock it securely.

The helmet wire is furnished in the tool kit (page 114).

### WARNING

Riding with a helmet attached to the holder can interfere with the rear wheel or suspension and could cause a crash in which you can be seriously hurt or killed.

Use the helmet holder only while parked. Do not ride with a helmet secured by the holder.

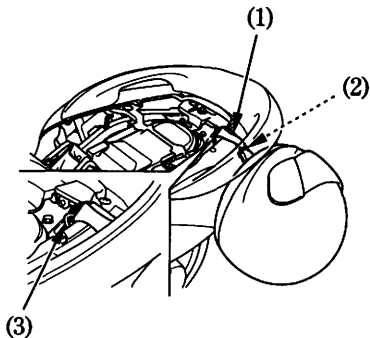

- (1) Helmet wire
- (2) Helmet D-ring

- (3) Helmet holder

## **DOCUMENT BAG**

The document bag (1) is in the document compartment (2) under the rear seat (page 71).

This owner's manual and other documents should be stored in the document bag. When washing your motorcycle, be careful not to flood this area with water.

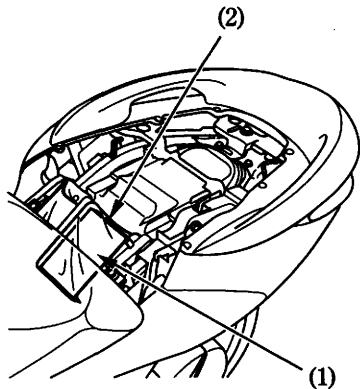

- (1) Document bag
- (2) Document compartment

## **STORAGE COMPARTMENT FOR U-SHAPED ANTI-THEFT LOCK**

There is a storage compartment to store a U-shaped anti-theft lock under the rear seat (page 71).

Some U-shaped locks may not be stored in the compartment due to their size or design.

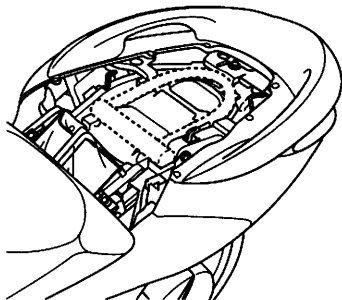

## RIGHT SIDE COVER

The right side cover must be removed to check the engine oil level and change the engine oil, engine oil filter and HFT oil filter.

Immediately after stopping the engine, the engine, exhaust pipe and muffler are too hot. Be careful not to burn yourself.

### Removal:

1. By pulling the right side cover (1) toward you with the notch (2), pull out the upper prongs (3) from the upper grommets (4).
2. By pulling up the right side cover, pull out the lower prong (5) from the lower grommet (6).

### Installation:

1. Align the lower prong with the lower grommet.
2. Align the upper prongs with the upper grommets
3. Push the prongs in.

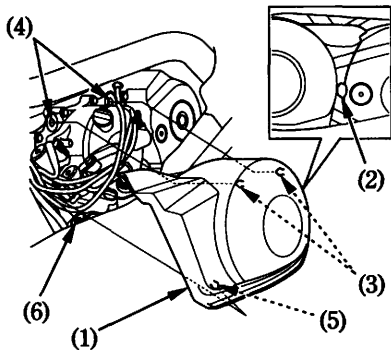

- |                      |                    |
|----------------------|--------------------|
| (1) Right side cover | (4) Upper grommets |
| (2) Notch            | (5) Lower prong    |
| (3) Upper prongs     | (6) Lower grommet  |

## REAR COWL

The right rear cowl must be removed to inspect the coolant reserve tank. The left rear cowl must be removed for battery maintenance.

The right and left rear cowls can be removed in the same manner.

### Removal:

1. Remove the rear seat (page 71 ).
2. Remove the clips A (1) and rear center cowl (2).

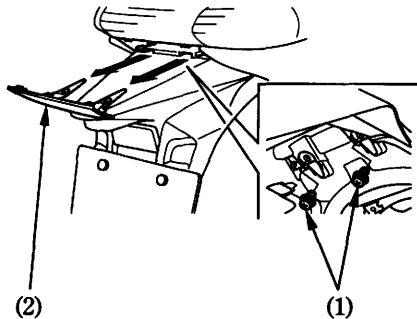

(1) Clips A

(2) Rear center cowl

3. Remove the screws A (3) and screws B (4).

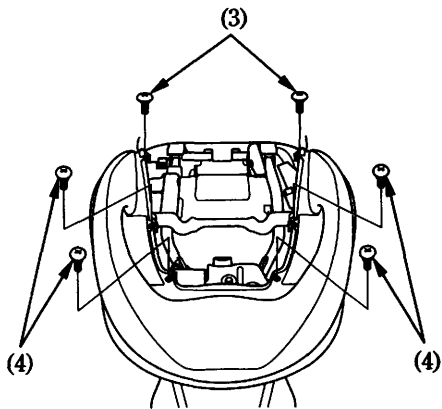

(3) Screws A

(4) Screws B

4. To remove the grab rail cover (5), pull it outwards and remove the tabs (6) starting from the front.

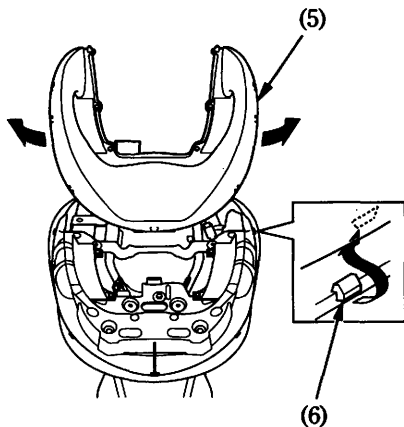

(5) Grab rail cover

(6) Tab

5. Remove the clips A (6).
6. Pull the front of the rear cowl (7) (8) forward and carefully pull the rear cowl out from the grommets (9).

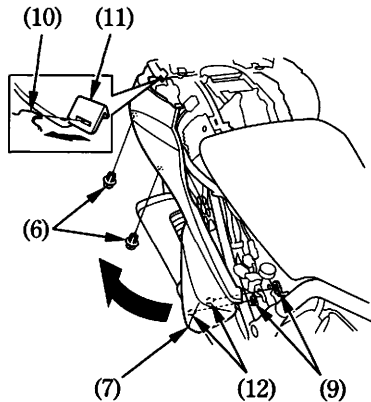

- (6) Clips A  
 (7) Right rear cowl

7. Remove the upper tab (10) on the center of the rear cowl from the hook (11).

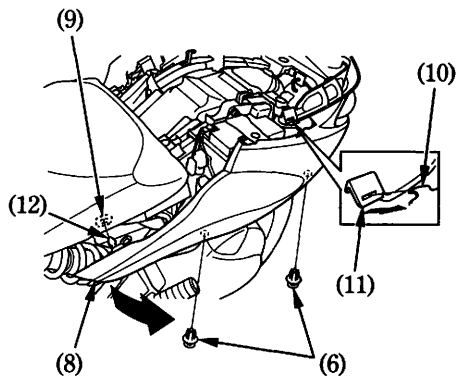

- (8) Left rear cowl  
 (9) Grommets  
 (10) Upper tab  
 (11) Hook  
 (12) Prongs

8. While sliding the rear cowl back, remove the rear tabs (12) from the rear fender and remove the rear cowl.

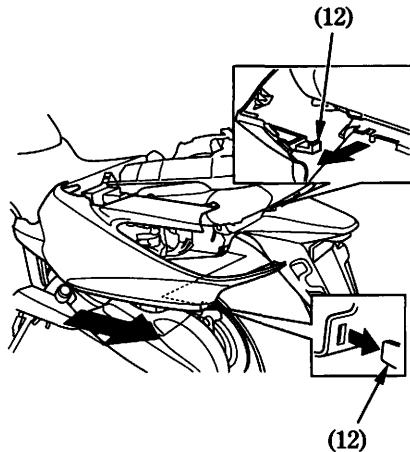
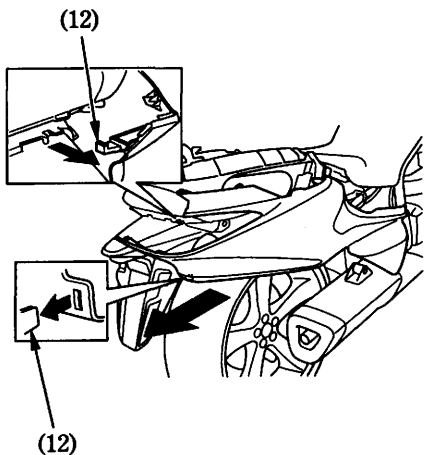

(12) Rear tabs

### Installation:

1. Attach the rear cowl in the reverse order of removal.
2. Attach the center hook (13) of the grab rail cover (5) to the tab (14). Then, install the grab rail cover so that the center hook does not slip.

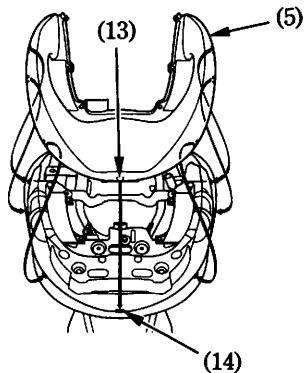

- (5) Grab rail cover  
(13) Center hook

- (14) Tab

3. Install the screws A (3) and screws B (4).
4. Install the rear center cowl and clips A.
5. Install the rear seat (page 71).

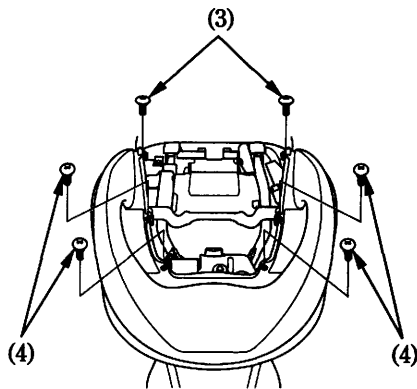

- (3) Screws A  
(4) Screws B