



**OWNER'S MANUAL**

**ST1100**

**HONDA**



---

## IMPORTANT NOTICE

- **OPERATOR AND PASSENGER**

This motorcycle is designed to carry the operator and one passenger. Never exceed the maximum weight capacity as shown on the tyre information label.

- **ON-ROAD USE**

This motorcycle is designed to be used only on the road.

- **READ THIS OWNER'S MANUAL CAREFULLY**

Pay special attention to statements preceded by the following words:

**⚠ WARNING**

***Indicates a strong possibility of severe personal injury or death if instructions are not followed.***

**CAUTION:**

***Indicates a possibility of personal injury or equipment damage if instructions are not followed.***

**NOTE:** Gives helpful information.

This manual should be considered a permanent part of the motorcycle and should remain with the motorcycle when resold.



---

**HONDA PAN EUROPEAN  
ST1100  
OWNER'S MANUAL**

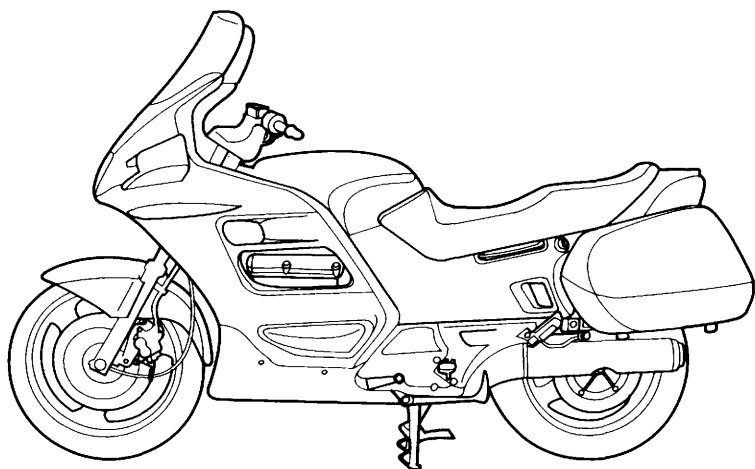

***All information in this publication is based on the latest production information available at the time of approval for printing. HONDA MOTOR CO., LTD. reserves the right to make changes at any time without notice and without incurring any obligation. No part of this publication may be reproduced without written permission.***

# WELCOME

---

The motorcycle presents you a challenge to master the machine, a challenge to adventure. You ride through the wind, linked to the road by a vehicle that responds to your commands as no other does. Unlike an automobile, there is no metal cage around you. Like an airplane, a pre-ride inspection and regular maintenance are essential to your safety. Your reward is freedom.

To meet the challenges safely, and to enjoy the adventure fully, you should become thoroughly familiar with this owner's manual **BEFORE YOU RIDE THE MOTORCYCLE.**

When service is required, remember that your Honda dealer knows your motorcycle best. If you have the required mechanical "know-how" and tools, your dealer can supply you with an official Honda Service Manual to help you perform many maintenance and repair tasks.

Pleasant riding, and thank you for choosing a Honda!

- Following codes in this manual indicate each country.

AR	Austria	IT	Italy
E	UK	N	Norway
ED	European direct sales Belguim Holland Portugal	ND	Northern Europe Sweden
F	France	SP	Spain
FI	Finland	SW	Switzerland
G	Germany	U	Australia

- The specifications may vary with each local.

# CONTENTS

---

## OPERATION

Page		Page	
1	MOTORCYCLE SAFETY	37	Helmet Holder
1	Safe Riding Rules	37	Cord Hook
2	Protective Apparel	38	Document Compartment
2	Modifications	39	Saddlebag
3	Loading and Accessories	41	Fairing Pocket
		42	Rear view mirror covers
		43	Headlight Beam Adjustment
6	PARTS LOCATION		
9	Instruments and Indicators	44	OPERATION
		44	Pre-ride Inspection
16	MAJOR COMPONENTS (Information you need to operate this motorcycle)	45	Starting the Engine
		47	Break-in
16	Rear Suspension	48	Riding
18	Brakes	49	Braking
21	Clutch	50	Anti-lock Brake System (ABS)
22	Coolant	54	Traction Control System (TCS)
24	Fuel		Parking
27	Engine Oil	58	Anti-theft Tips
29	Final Drive Oil	58	
30	Tubeless Tires		
33	ESSENTIAL INDIVIDUAL COMPONENTS		
33	Ignition Switch		
34	Right Handlebar Controls		
35	Left Handlebar Controls		
36	FEATURES (Not required for operation)		
36	Steering Lock		
36	Seat		

# CONTENTS

---

## MAINTENANCE

Page		Page	
59	MAINTENANCE	79	FRAME/WHEELS/ BRAKES
60	Maintenance Schedule	79	Front Wheel Removal
62	Tool Kit	83	Rear Wheel Removal
63	Serial Numbers	86	Brake Wear Indicators
63	Color Label	87	Side Stand
64	Maintenance Precau- tions	88	ELECTRICAL
65	Cover Removal	88	Battery
70	FILTERS/LUBRICATION	90	Fuse Replacement
70	Engine Oil And Filter	92	CLEANING
73	Air Cleaner	94	STORAGE GUIDE
75	ENGINE	94	Storage
75	Spark Plugs	95	Removal From Storage
77	Idle Speed	96	SPECIFICATIONS
78	DRIVE TRAIN	98	NOISE EMISSION (AUSTRALIA ONLY)
78	Final Drive Oil		

# MOTORCYCLE SAFETY

---

## SAFE RIDING RULES

### WARNING

- ***Motorcycle riding requires special efforts on your part to ensure your safety. Know these requirements before you ride:***
  1. Always make a pre-ride inspection (page 44) before you ride the motorcycle.  
You may prevent an accident or equipment damage.
  2. Many accidents involve inexperienced riders. Most states require a special motorcycle riding test or license. Make sure you are qualified before you ride. NEVER lend your motorcycle to an inexperienced rider.
  3. Many automobile/motorcycle accidents happen because the automobile driver does not “see” the motorcyclist.  
Make yourself conspicuous to help avoid the accident that wasn’t your fault:
    - Wear bright or reflective clothing.
    - Don’t ride in another motorist’s “blind spot.”
  4. Obey all national and local laws and regulations.
    - Excessive speed is a factor in many accidents. Obey the speed limits, and NEVER travel faster than conditions warrant.
    - Signal before you make a turn or lane change. Your size and maneuverability can surprise other motorists.
  5. Don’t let other motorists surprise you. Use extra caution at intersections, parking lot entrances and exits, and driveways.
  6. Keep both hands on the handlebars and both feet on the footpegs while riding. A passenger should hold on to the motorcycle or the operator with both hands and keep both feet on the passenger footpegs.

### CAUTION:

- ***Do not ride over curbs or rub the wheel against an obstacle, as wheel damage may result.***

# MOTORCYCLE SAFETY

---

## PROTECTIVE APPAREL

1. Most motorcycle accident fatalities are due to head injuries: ALWAYS wear a helmet. You should also wear a face shield or goggles as well as boots, gloves, and protective clothing. A passenger needs the same protection.
2. The exhaust system becomes hot during operation, and it remains hot for a while after stopping the engine. Be careful not to touch the exhaust system while it is hot. Wear clothing that fully covers your legs.
3. Do not wear loose clothing which could catch on the control levers, footpegs, or wheels.

## MODIFICATIONS

### WARNING

- ***Modification of the motorcycle, or removal of original equipment, may render the vehicle unsafe or illegal. Obey all federal, state and local equipment regulations.***

---

## LOADING AND ACCESSORIES

### **▲ WARNING**

- ***To prevent an accident, use extreme care when adding and riding with accessories and cargo. Addition of accessories and cargo can reduce a motorcycle's stability, performance and safe operating speed. Never ride an accessory-equipped motorcycle at speeds above 130 km (80 mph). And remember that this 130 km (80 mph) limit may be reduced by installation of non-Honda accessories, improper loading, worn tires and overall motorcycle condition, poor road or weather conditions. These general guidelines may help you decide whether or how to equip your motorcycle, and how to load it safely.***

### **Loading**

The combined weight of the rider, passenger, cargo and additional accessories must not exceed 205 kg (452 lbs), 195 kg (430 lb); Equipped with the ABS and TCS, the maximum weight capacity. Cargo weight alone should not exceed 27 kg (60 lbs).

1. Keep cargo and accessory weight low and close to the center of the motorcycle. Load weight equally on both sides to minimize imbalance. As weight is located farther from the motorcycle's center of gravity, handling is proportionally affected.
2. Adjust tire pressure (page 30).
3. All cargo and accessories must be secure for stable handling. Recheck cargo security and accessory mounts frequently.

# **MOTORCYCLE SAFETY**

---

4. Do not attach large, heavy items to the handlebars, fork, or fender. Unstable handling or slow steering response may result.
5. Do not exceed the maximum weight capacity of Honda accessories.
  - Saddlebag: 9 kg (20 lbs) Each side
  - Fairing pocket: 2 kg (5 lbs) Each side
6. The Honda fairing and saddlebag are designed for this motorcycle only. Do not install them on any other motorcycle.
7. Do not store articles between fairing and motorcycle. They may interfere with steering causing loss of control.
8. Do not use the handlebars to hold the motorcycle with a rope during transportation or the handlebars may be bent.

## **Accessories**

Genuine Honda accessories have been specifically designed for and tested on this motorcycle. Because the factory cannot test all other accessories, you are personally responsible for proper selection, installation, and use of non-Honda accessories.

Always follow the guidelines under Loading, and these:

1. Carefully inspect the accessory to make sure it does not obscure any lights, reduce ground clearance and banking angle, or limit suspension travel, steering travel or control operation.
2. Large fork-mounted fairings or windshields, or poorly designed or improperly mounted fairings can produce aerodynamic forces that cause unstable handling. Do not install fairings that decrease cooling air flow to the engine.

- 
3. Accessories which alter your riding position by moving hands or feet away from controls may increase reaction time in an emergency.
  4. Do not add electrical equipment that will exceed the motorcycle's electrical system capacity. A blown fuse could cause a dangerous loss of lights or engine power.
  5. This motorcycle was not designed to pull a sidecar or trailer. Handling may be seriously impaired if so equipped.
  6. Any modification of the cooling system may cause overheating and serious engine damage. Do not modify the radiator shrouds or install accessories which block or deflect air away from the radiator.

# PARTS LOCATION

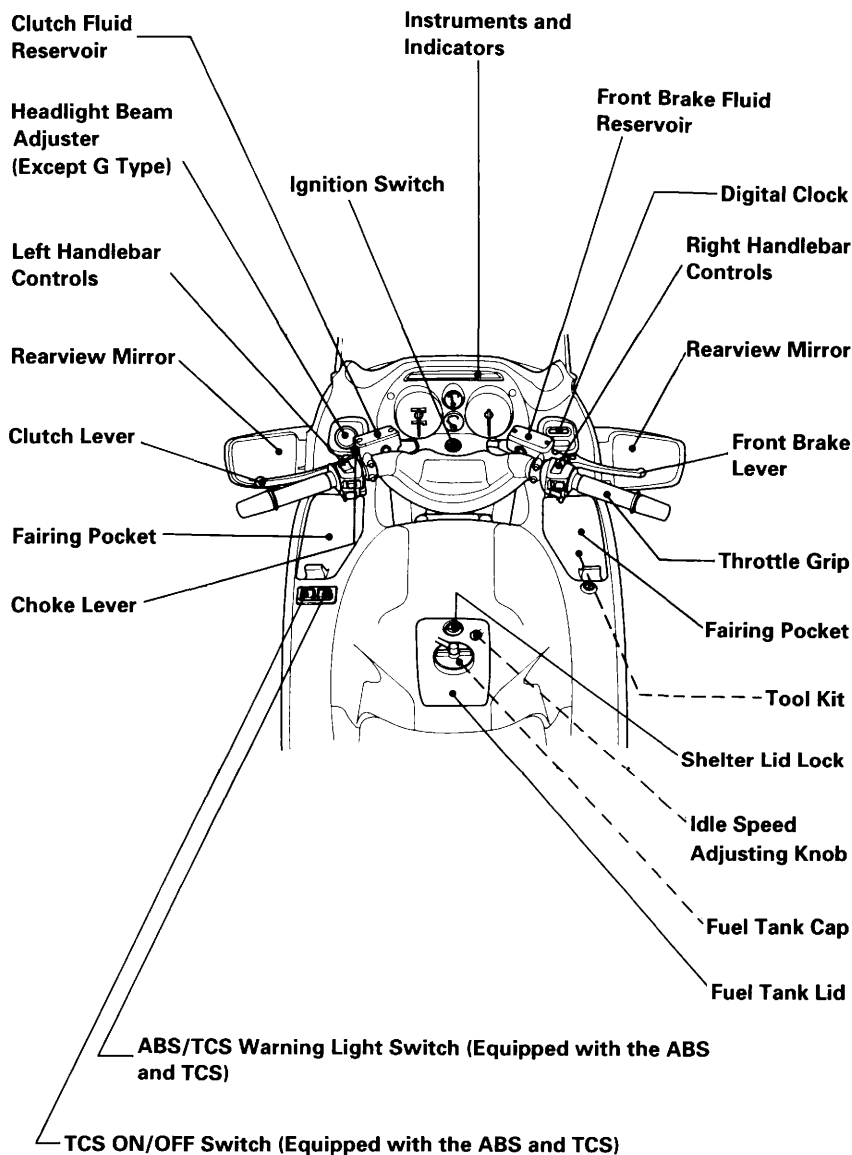

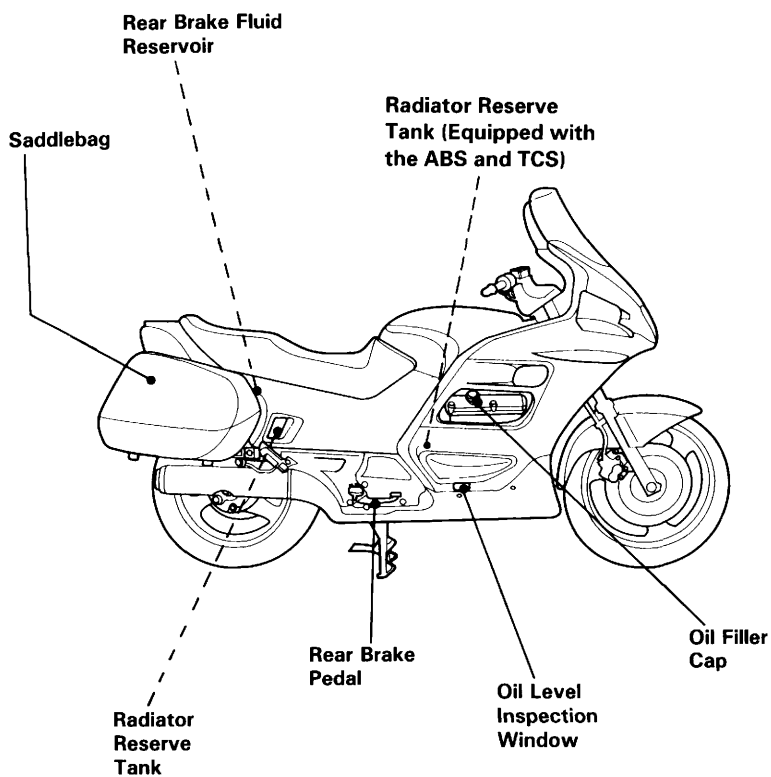

# PARTS LOCATION

---

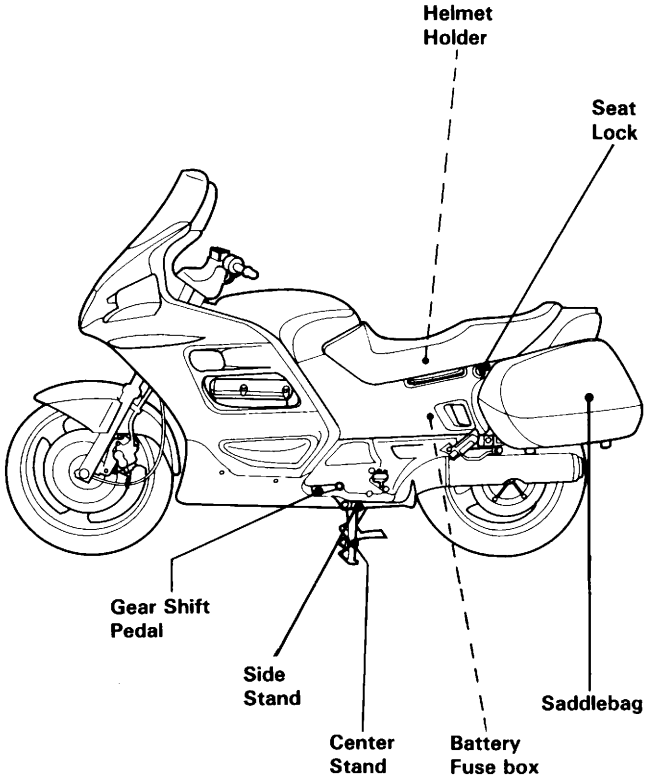

## INSTRUMENTS AND INDICATORS

The indicators and warning lights are incorporated in the instrument panel. Their functions are described on the following pages.

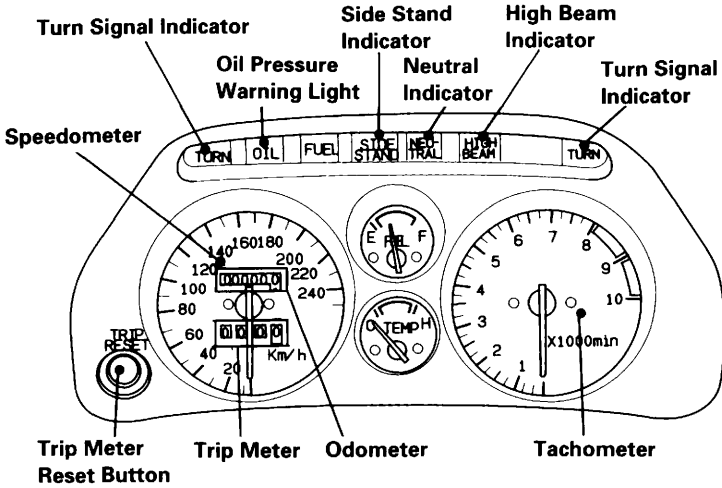

(For Some Types)

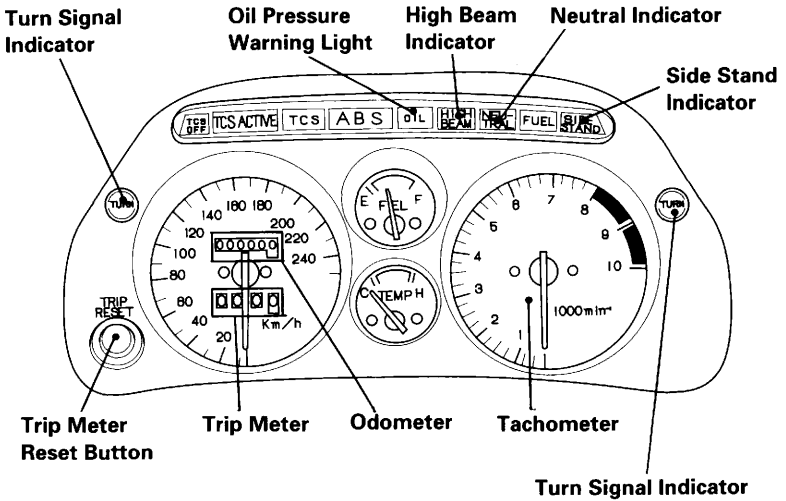

# PARTS LOCATION

---

**Speedometer:** shows riding speed.

**Tachometer:** shows engine rpm.

Never allow the tachometer needle to enter the red zone, even after the engine has been broken in.

**CAUTION:**

- *The red zone indicates the maximum limits of engine speed and running the engine in the red zone may adversely affect its service life.*

**Turn Signal Indicators (amber):** Flashes when the turn signal operates.

**Odometer:** Shows accumulated mileage.

**Tripmeter:** Shows mileage per trip.

**Tripmeter Reset Button:** Pushing the button resets the tripmeter to zero (0)

**High Beam Indicator (blue):** Lights when the headlight is on high beam.

**Neutral Indicator (green):** Lights when the transmission is in neutral.

**Oil Pressure Warning Light (red):**

Lights when engine oil pressure is below the normal operating range. Should also light when the ignition switch is ON and the engine is not running. Should go off when the engine starts, except for occasional flickering at or near idling speed when the engine is warm.

**CAUTION:**

- *Running the engine with insufficient oil pressure may cause serious engine damage.*

**Side Stand Indicator (amber):**

Lights when the side stand is put down.

Before parking, check that the side stand is fully down; the light only indicates the side stand ignition cut-off system (page 87) is activated.

## Fuel Reserve System Indicator:

When this lamp comes on while riding, there is about 5 liters (1.3 US gal, 1.1 Imp gal) left in the tank. Should also light for a few seconds and go off when the ignition switch is turned ON.

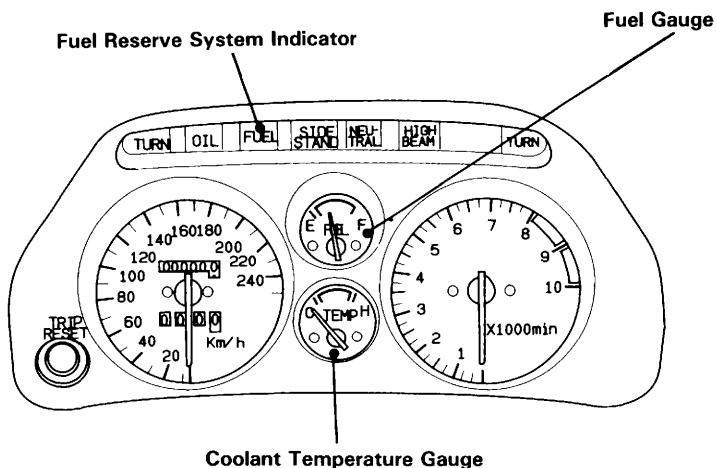

(For Some Types)

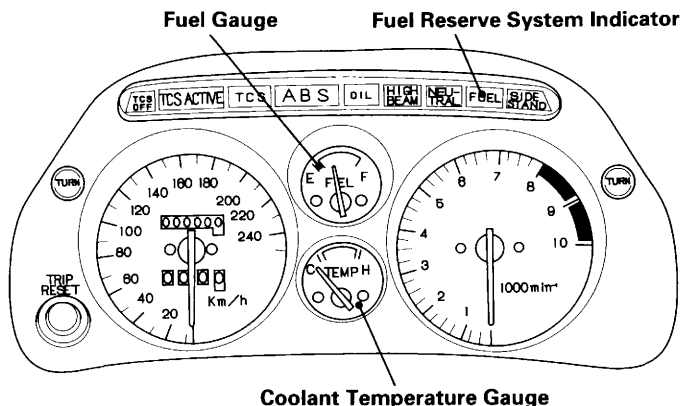

## **PARTS LOCATION**

---

### **Fuel Gauge**

The fuel gauge shows the approximate fuel supply available. At F (Full) there are 28 liters (7.4 US gal, 6.1 Imp gal), including the reserve supply.

When the gauge needle enters the red band, the fuel level is low and you should refill the tank as soon as possible. The amount of fuel left in the tank when the needle enters the red band is approximately 3.5 liters (0.9 US gal, 0.8 Imp gal)

### **Coolant Temperature Gauge**

The normal operating temperature range is the zone between the C (cold) and H (hot) marks. Wait for the temperature gauge needle to move above the C mark before riding. If the needle reaches the H mark, stop the engine and check the reserve tank coolant level (page 21).

Do not ride the motorcycle until the problem has been corrected.

### **CAUTION:**

- ***Exceeding maximum running temperature may cause serious engine damage.***

(For Some Types)

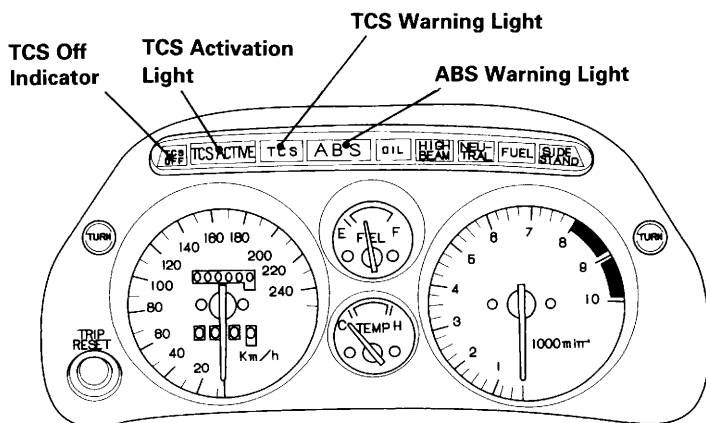

### **Anti-lock Brake System (ABS) Warning Light**

This light normally comes on when the ignition is turned ON and goes off after starting to ride.

If there is a problem with the Anti-lock Brake System, this light comes on and remains on — or blinks. (See chart on page 14.) For information about ABS, see page 50.

### **Traction Control System (TCS) Warning Light**

This light normally comes on when the ignition is turned ON and goes off after starting to ride.

If there is a problem with the Traction Control System, this light comes on and remains on — or blinks. (See chart on page 14.) For more information about TCS, see page 54.

### **TCS Activation Light**







This light lights when the traction control system is activated to regulate the engine (see page 54). It will normally light for a few seconds when you turn the main switch ON.

### **TCS Off Indicator**

This indicator lights when the traction control system is OFF (see pages 55 and 56). It will normally light for a few seconds when you turn the ignition ON.

# PARTS LOCATION

## ABS and TCS Warning Light Operation

	Ignition "ON"	After Starting to Ride	Normal: OK Faulty: NG
ABS Warning Light	 <input type="checkbox"/> Comes ON   Blinks	  <ul style="list-style-type: none"> <li>Goes OFF</li> <li>Remains ON</li> <li>Blinks</li> </ul>	OK NG NG NG
TCS Warning Light	<input type="checkbox"/> Comes ON   Blinks	 <ul style="list-style-type: none"> <li>Goes OFF</li> <li>Remains ON</li> <li>Blinks</li> </ul>	OK NG NG NG

If either the ABS or TCS Warning Light does not operate properly,  
See your authorized Honda dealer for service.

---

## Digital clock

Shows hour and minute. To adjust time, proceed as follows:

1. Turn the main switch ON.
2. Press the RST button (Reset button). The minute display will read "00".
3. Press the "H" button (Hour button). To advance time, keep the button down until the desired hour is displayed.
4. Press the "M" button (Minute button). To advance, hold the button down. The display will be returned to "00" when "60" minutes are reached without affecting the hour display.

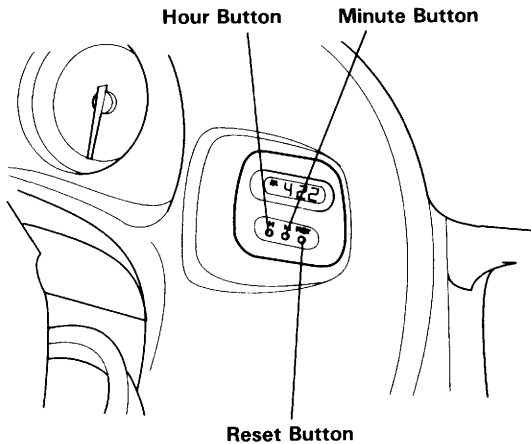

## MAJOR COMPONENTS

(Information you need to operate this motorcycle)

---

### **⚠ WARNING**

- *If the Pre-ride Inspection (page 44) is not performed, severe personal injury or vehicle damage may result.*

## REAR SUSPENSION

Spring preload adjustment:

The rear shock absorber has five adjustment positions for different load or riding conditions.

Remove the right saddlebag (page 40).

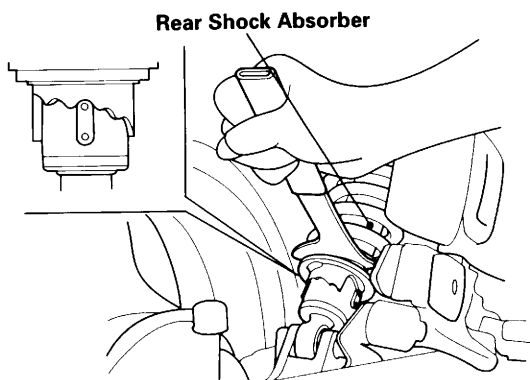

### Damping adjustment:

The damping adjuster has four adjustment positions.

Remove the right side cover (page 66)

To adjust the adjuster to the standard position, proceed as follows:

1. Turn the adjuster clockwise until it will no longer go.
2. The adjuster is set in the standard position when the adjuster is turned counterclockwise 1 turn with aligned the punch marks on the adjuster and the reference mark.

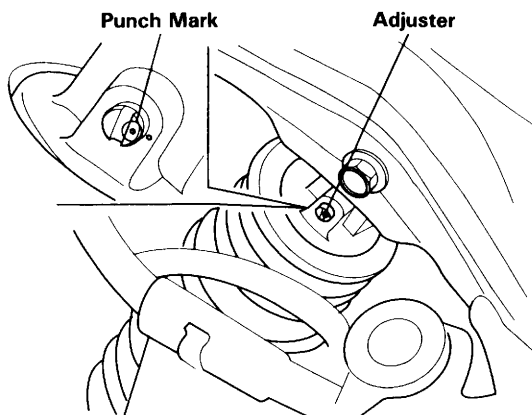

### Recommended damping adjuster positions:

CONDITIONS		DAMPING ADJUSTER Turn to clockwise from standard position	SPRING PRELOAD
Rider	Cargo		
One	—	0°	1 or 2
One	Cargo	180°	3
Two	—	270°	4
Two	Cargo	270° or 360°	5

## MAJOR COMPONENTS

### (Information you need to operate this motorcycle)

---

#### BRAKES

Both front and rear brakes are hydraulic disc types.

As the brake pads wear, the brake fluid level will drop. Therefore, the brake fluid level and pad wear must be inspected periodically. The system must be inspected frequently to ensure there are no fluid leaks.

#### NOTE:

If the control lever or pedal free travel becomes excessive and the brake pads are not worn beyond the recommended limit (page 86), there is probably air in the brake system and it must be bled. See your authorized Honda dealer for this service.

#### **▲ WARNING**

- ***Brake fluid may cause irritation. Avoid contact with skin or eyes. In case of contact, flush thoroughly with water and call a doctor if your eyes were exposed.***
- ***KEEP OUT OF REACH OF CHILDREN.***

#### CAUTION:

- ***When adding brake fluid, be sure the reservoir is horizontal before the cap is removed or brake fluid may spill out.***
- ***Use only DOT 4 brake fluid from a sealed container.***
- ***Never allow contaminants such as dirt or water to enter the brake fluid reservoir.***
- ***Handle brake fluid with care because it can damage plastic and painted surfaces.***

---

### Front Brake Fluid Level:

The front brake motor cylinder is located on the right handlebar. Fill the reservoir with DOT 4 BRAKE FLUID from a sealed container up to the upper level mark.

Reinstall the removed parts in the reverse order of removal. Tighten the screws securely.

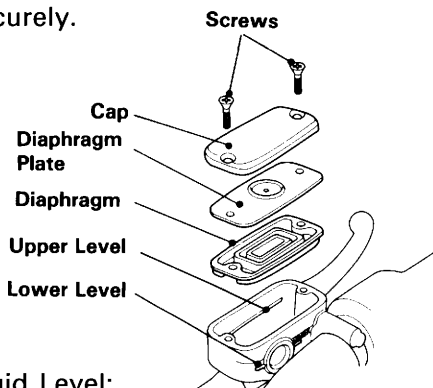

### Rear Brake Fluid Level:

1. Remove the right saddlebag (page 38).
2. Brake fluid must be added to the reservoir whenever the fluid level begins to reach the lower level mark.
3. Remove the cap.
4. Fill the reservoir with DOT 4 BRAKE FLUID from a sealed container up to the upper level mark.
5. Reinstall the removed the cap.

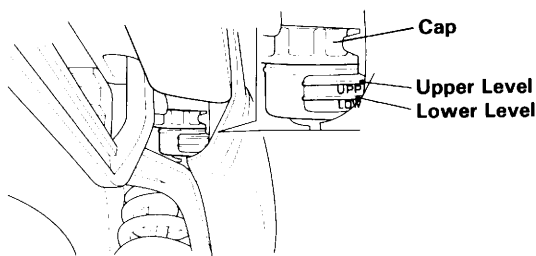

### Other Checks:

Make sure there are no fluid leaks. Check for deterioration or cracks in the hoses and fittings.

## MAJOR COMPONENTS

### (Information you need to operate this motorcycle)

---

#### Front Brake Lever:

The distance between the tip of the brake lever and the grip can be adjusted by turning the adjuster.

#### **CAUTION:**

- ***Align the arrow on the brake lever with index mark on the adjuster.***

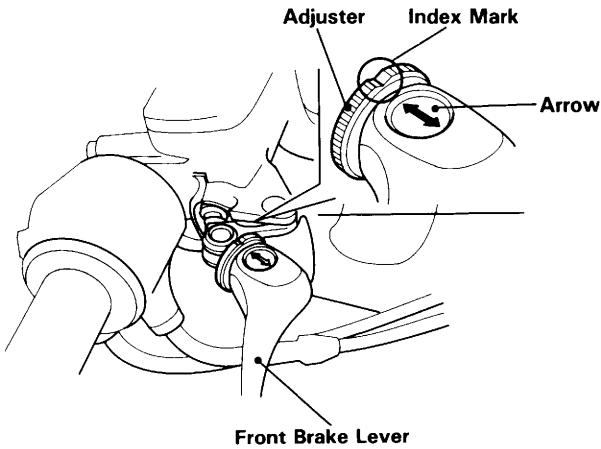

---

## CLUTCH

This motorcycle has a hydraulically actuated clutch. There are no adjustments to perform but the clutch system must be inspected periodically for fluid level and leakage. If the control lever freeplay becomes excessive and the motorcycle creeps or stalls when shifted into gear, or if the clutch slips, causing acceleration to lag behind engine speed, there is probably air in the clutch system and it must be bled out. See your authorized Honda dealer for this service.

### Fluid level:

Check that the fluid level is above the LOWER LEVEL LINE. If the fluid level is near the LOWER LEVEL LINE, it indicates fluid leakage. See your authorized Honda dealer for repair.

### Other Checks:

Make sure there are no fluid leaks. Check for deterioration or cracks in the hose and fittings.

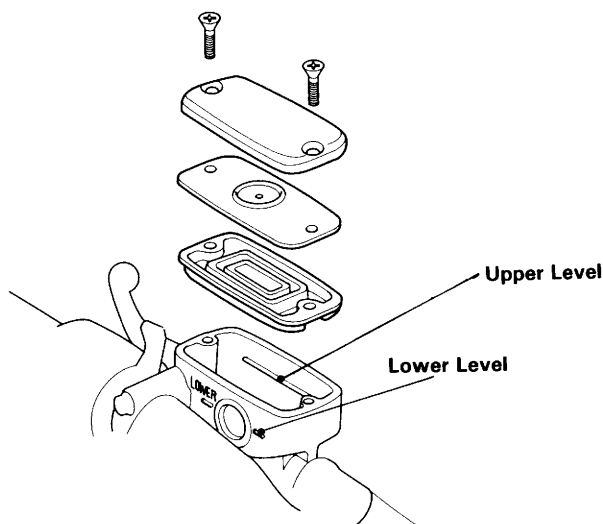

## MAJOR COMPONENTS

### (Information you need to operate this motorcycle)

---

## COOLANT

### Coolant Recommendation

The owner must properly maintain the coolant to prevent freezing, overheating, and corrosion. Use only high quality ethylene glycol antifreeze containing corrosion protection inhibitors specifically recommended for use in aluminum engines. (SEE ANTIFREEZE CONTAINER LABEL).

### CAUTION:

- ***Use only low-mineral drinking water or distilled water as a part of the antifreeze solution. Water that is high in mineral content or salt may be harmful to the aluminum engine.***

The factory provides a 50/50 solution of antifreeze and water in this motorcycle. This coolant solution is recommended for most operating temperatures and provides good corrosion protection. A higher concentration of antifreeze decreases cooling system performance and is recommended only when additional protection against freezing is needed. A concentration of less than 40/60 (40% antifreeze) will not provide proper corrosion protection. During freezing temperatures, check the cooling system frequently and add higher concentrations of antifreeze (up to a maximum of 60% antifreeze) if required.

### Inspection

The reserve tank is behind the right side cover or right side cowl (Equipped with the ABS and TCS). Check the coolant level in the reserve tank while the engine is at normal operating temperature. If the coolant is low, remove the right side cover or right side cowl (page 66) and add coolant to the reserve tank as required to bring the coolant level to the UPPER level mark.

If the reserve tank is empty, or if coolant loss is excessive, check for leaks and see your authorized Honda dealer for repair.

### **▲ WARNING**

- ***Do not remove the radiator cap when the engine is hot. The coolant is under pressure and could scald you.***
- ***Keep hands and clothing away from the cooling fan, as it starts automatically.***

**NOTE:**

- Do not remove the rubber protector.

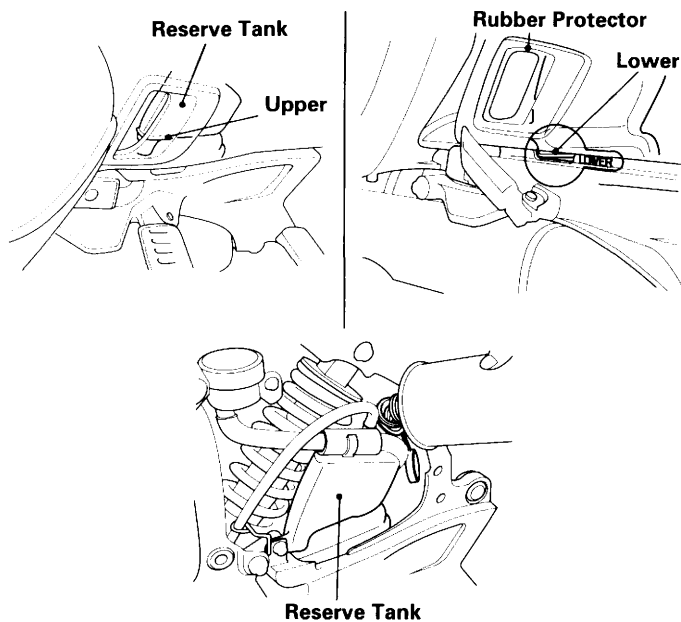

(Equipped with the ABS and TCS)

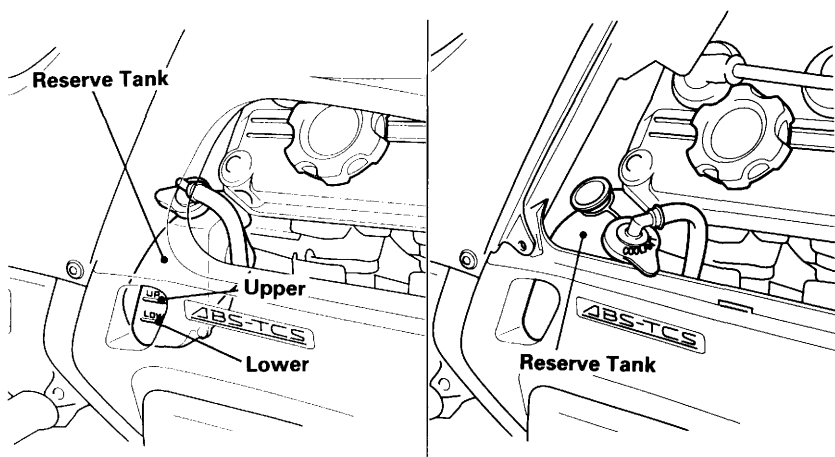

# MAJOR COMPONENTS

## (Information you need to operate this motorcycle)

---

### FUEL

#### Automatic Fuel ON-OFF

Fuel will flow to the carburetors only when the engine is started or is running.

#### Fuel Tank

Fuel tank capacity is 28 l (7.4 US gal, 6.1 Imp gal). Insert the ignition key and turn it clockwise to open the fuel filler compartment. Turn the fuel tank cap counterclockwise to remove it.

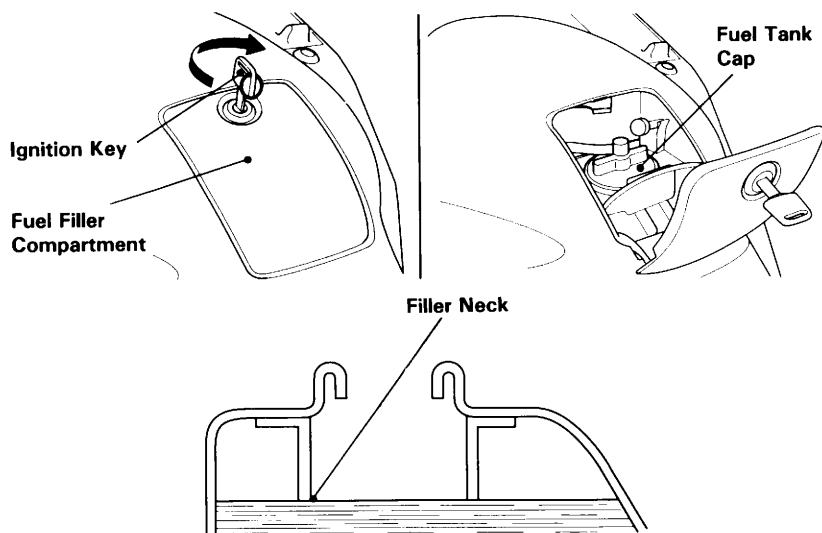

Use unleaded or low-lead petrol with a research octane number of 91 or higher. We recommend that you use unleaded petrol because it produces fewer engine and spark plug deposits and extends the life of exhaust system components.

#### FOR AUSTRALIA ONLY:

Use unleaded petrol with a research octane number of 91 or higher.

Never use stale or contaminated petrol or an oil/petrol mixture. Avoid getting dirt, dust or water in the fuel tank. Use of a lower octane petrol can cause persistent "pinging" or heavy "spark knock" (a metallic rapping noise) which, if severe, can lead to engine damage.

---

**CAUTION:**

- ***If “spark knock” or “pinging” occurs at a steady engine speed under normal load, change brands of petrol. If spark knock or pinging persists, consult your authorized Honda dealer. Failure to do so is considered misuse, and damage caused by misuse is not covered by Honda’s Limited Warranty.***

Occasionally you may experience light spark knock while operating under heavy loads. This is no cause for concern, it simply means your engine is operating efficiently.

Install the fuel tank cap by turning it clockwise. Be sure to properly route the hose attached to the top of the cap.

Close the fuel filler compartment lid with the key inserted and turned clockwise, then turn the key counterclockwise to lock the lid.

**▲ WARNING**

- ***Petrol is extremely flammable and is explosive under certain conditions. Refuel in a well-ventilated area with the engine stopped. Do not smoke or allow flames or sparks in the area where petrol is stored or where the fuel tank is refueled.***
- ***Do not overfill the tank (there should be no fuel in the filler neck). After refueling, make sure the tank cap is closed properly and securely.***
- ***Be careful not to spill fuel when refueling. Spilled fuel or fuel vapor may ignite. If any fuel is spilled, make sure the area is dry before starting the engine.***
- ***Avoid repeated or prolonged contact with skin or breathing of vapor. KEEP OUT OF REACH OF CHILDREN.***

## **MAJOR COMPONENTS**

### **(Information you need to operate this motorcycle)**

---

#### **Petrol Containing Alcohol**

If you decide to use a petrol containing alcohol (gasohol), be sure its octane rating is at least as high as that recommended by Honda. There are two types of "gasohol": one containing ethanol, and the other containing methanol. Do not use gasohol that contains more than 10% ethanol. Do not use petrol containing methanol (methyl or wood alcohol) that does not also contain cosolvents and corrosion inhibitors for methanol. Never use petrol containing more than 5% methanol, even if it has cosolvents and corrosion inhibitors.

#### **NOTE:**

- Fuel system damage or engine performance problems resulting from the use of fuels that contain alcohol are not covered under the warranty. Honda cannot endorse the use of fuels containing methanol since evidence of their suitability is as yet incomplete.
- Before buying fuel from an unfamiliar station, try to find out if the fuel contains alcohol. If it does, confirm the type and percentage of alcohol used. If you notice any undesirable operating symptoms while using a petrol that contains alcohol, or one that you think contains alcohol, switch to a petrol that you know does not contain alcohol.

---

## ENGINE OIL

Check engine oil level each day before operating the motorcycle.

### To check the oil level:

1. Place the motorcycle on its center stand on firm, level ground.
2. Start the engine and let it idle for a few minutes.
3. Stop the engine. After a few minutes, check the oil level inspection window.

The oil level should be between the upper and lower level marks.

4. If required, remove the airduct/maintenance cover (page 66) and filler cap, add the specified oil up to the upper level mark. Do not overfill.
5. Reinstall the filler cap.

### CAUTION:

- ***Running the engine with insufficient oil can cause serious engine damage.***

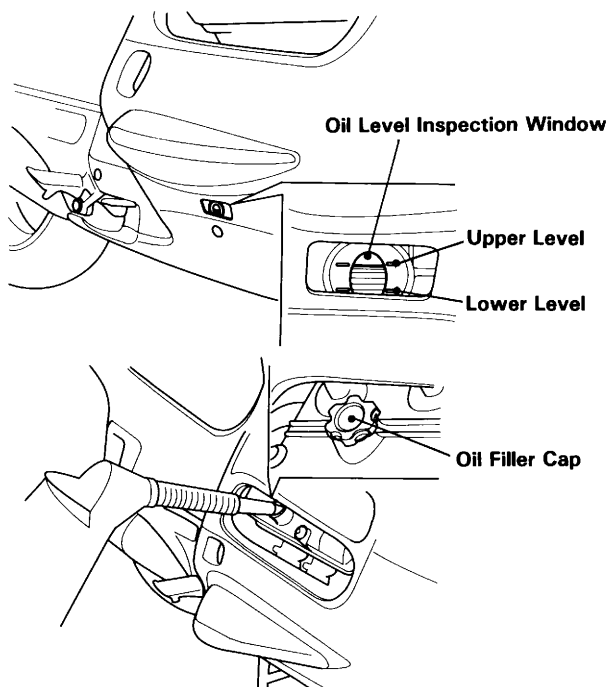

# MAJOR COMPONENTS

## (Information you need to operate this motorcycle)

### Engine Oil

Good engine oil has many desirable qualities. Use only high detergent, quality motor oil certified on the container to meet or exceed requirements for service SE, SF or SG.

### Viscosity

Viscosity grade of engine oil should be based on average atmospheric temperature in your riding area. The following provides a guide to the selection of the proper grade or viscosity of oil to be used at various atmospheric temperatures.

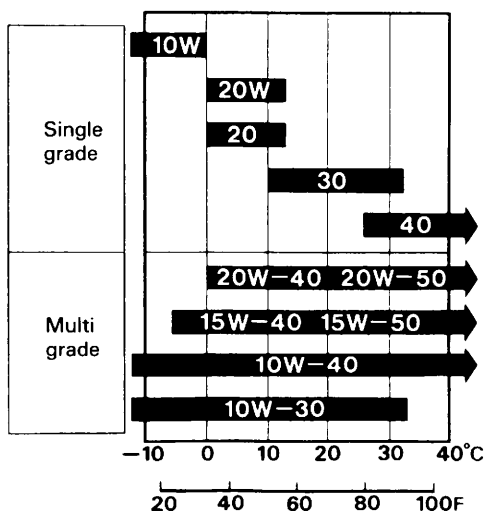

---

## FINAL DRIVE OIL

### Oil Level Check

Check the final drive oil level when specified by the maintenance schedule.

1. Place the motorcycle on its center stand on firm, level ground.
2. Remove the oil filler cap.
3. The oil level should be flush with the lower edge of the oil filler hole.

### NOTE:

- If the level is low, check for leaks. Add the recommended oil through the oil filler hole until it reaches the lower edge of the opening.

**Recommended Oil: HYPOID GEAR OIL SAE 80**

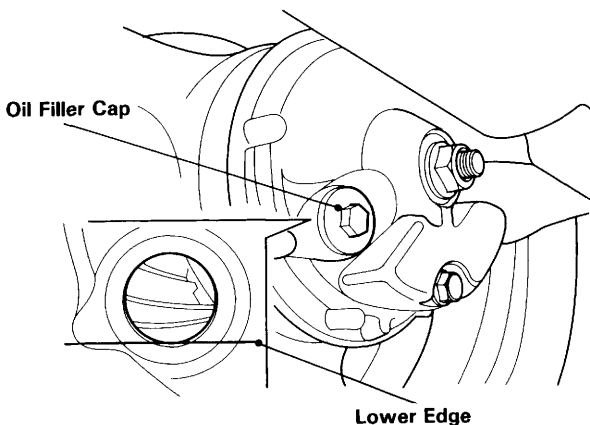

## MAJOR COMPONENTS

### (Information you need to operate this motorcycle)

#### TUBELESS TIRES

This motorcycle is equipped with tubeless tires, valves, and wheel rims. Use only tires marked "TUBELESS" and tubeless valves on rims marked "TUBELESS TIRE APPLICABLE."

Never mount tires designed for use on automobiles on a motorcycle rim.

#### WARNING

- ***Any attempt to mount passenger car tires on a motorcycle rim may cause the tire bead to separate from the rim with enough explosive force to cause serious injury or death.***

Proper air pressure will provide maximum stability, riding comfort, proper ABS and TCS operation (For some types) and tire life. Check tire pressure frequently and adjust if necessary.

#### NOTE:

- Tire pressure should be checked before you ride while the tires are "cold."
- Tubeless tires have some degree of self-sealing ability if they are punctured, and leakage is often very slow. Inspect very closely for punctures, especially if the tire is not fully inflated.

		Front	Rear
TIRE SIZE		110/80V18	160/70V17
TIRE BRAND			
TUBELESS ONLY			
DUNLOP		K505F	K505
BRIDGESTONE		G547	G548
TIRE SIZE		110/80V18—V240	160/70VB17—V240
TIRE BRAND			
TUBELESS ONLY			
METZELER		ME33 LASER	ME55A METRONIC
Cold tire pressures psi (kPa, kg/cm <sup>2</sup> )	Up to 90 kg (200 lbs) load	36 (250, 2.50)	42 (290, 2.90)
	90 kg (200 lbs) load to vehicle capacity load	36 (250, 2.50)	42 (290, 2.90)

---

Check the tires for cuts, embedded nails or other sharp objects. Check the rims for dents or deformation. If there is any damage, see your authorized Honda dealer for repair, replacement, and balancing.

**⚠ WARNING**

- ***Improper tire inflation will cause abnormal tread wear and create a safety hazard. Underinflation may result in the tire slipping on, or coming off of the rim causing tire deflation that may result in a loss of vehicle control.***
- ***Operation with excessively worn tires is hazardous and will adversely affect traction and handling.***

Replace tires before tread depth at the center of the tire reaches the following limit or when the surface is flush with the wear indicators.

Minimum tread depth	
Front:	1.5 mm (0.06 in)
Rear:	2.0 mm (0.08 in)

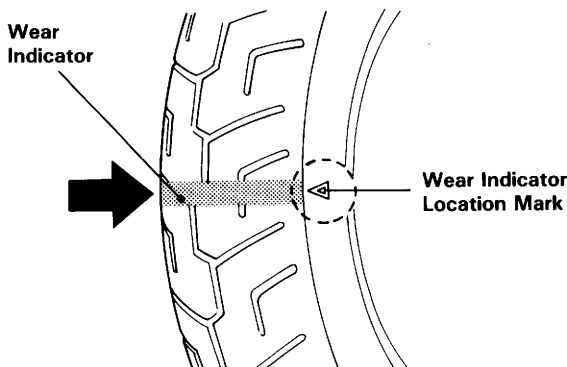

## MAJOR COMPONENTS

### (Information you need to operate this motorcycle)

---

#### Tire Repair/Replacement

See your authorized Honda Dealer.

#### **▲ WARNING**

- *The use of tires other than those listed on the tire information label may adversely affect handling.*
- *Do not install tube-type tires on tubeless rims. The beads may not seat and the tires could slip on the rims, causing tire deflation that may result in a loss of vehicle control.*
- *Any attempt to mount passenger car tires on a motorcycle rim may cause the tire bead to separate from the rim with enough explosive force to cause serious injury or death.*
- *Do not install a tube inside a tubeless tire. Excessive heat build-up may cause the tube to burst resulting in rapid tire deflation that may result in a loss of vehicle control.*
- *Proper wheel balance is necessary for safe, stable handling of the motorcycle. Do not remove or change any wheel balance weights. When wheel balancing is required, see your authorized Honda dealer. Wheel balancing is required after tire repair or replacement.*
- *To avoid possible repair failure and tire deflation that may result in a loss of vehicle control, do not exceed 80 km (50 mph) for the first 24 hours, or 130 km (80 mph) at any time, after tire repair.*
- *Replace the tire if the sidewall is punctured or damaged. Sidewall flexing may cause repair failure and tire deflation that may result in a loss of vehicle control.*

#### CAUTION:

- *Do not try to remove tubeless tires without special tools and rim protectors. You may damage the rim sealing surface or disfigure the rim.*
- *When replacing tires, use the same tires those listed on the tire information label. Use of other tires may impair in the proper ABS and TCS function (Equipped with the ABS and TCS).*

# ESSENTIAL INDIVIDUAL COMPONENTS

## IGNITION SWITCH

The ignition switch is on the handlebar cover.

Key Position	Function Key	Key Removal
ON	All electrical circuits are on. Engine and lights can be operated.	Key cannot be removed.
OFF	All electrical circuits are off. (Except for Digital clock) Engine cannot be started.	Key can be removed.
P (parking) <AR Type>	For parking the motorcycle near traffic. The taillight and position light are on, but all other lights are off. The engine cannot be started.	Key can be removed.
LOCK (steering lock)	Steering is locked. Engine and lights cannot be operated.	Key can be removed.

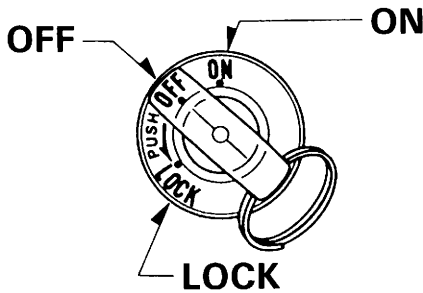

# **ESSENTIAL INDIVIDUAL COMPONENTS**

---

## **RIGHT HANDLEBAR CONTROLS**

### **Engine Stop Switch**

The two position engine stop switch is next to the throttle grip. When the switch is in the RUN position, the engine will operate. When the switch is in the OFF position, the engine will not operate. This switch is intended primarily as a safety or emergency switch and should normally remain in the RUN position.

#### **NOTE:**

- If your motorcycle is stopped with the ignition switch ON and the engine stop switch OFF, the headlight and taillight will still be on, resulting in battery discharge.

### **Starter Button**

The starter button is below the engine stop switch. When the starter button is pressed, the starter motor will crank the engine. See pages 45—46 for “Starting Procedure.”

### **Headlight Switch**

The headlight switch has three positions, “H,” “P” and “OFF” marked by dot.

H: Headlight, taillight, position light and meter lights on.

P: Position light, taillight and meter lights on.

OFF (dot): Headlight, taillight, position light and meter lights off.

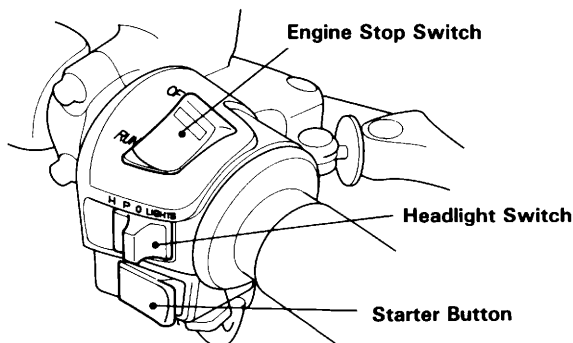

---

## LEFT HANDLEBAR CONTROLS

The controls next to the left handlebar grip are:

### Headlight Dimmer Switch

Select HI for high beam, LO for low beam.

### Horn Button

Press the button to sound the horn.

### Turn Signal Switch

Move the switch to L to signal a left turn, to R to signal a right turn; the appropriate turn signal and indicator will blink. Push to turn signal off.

### Passing Light Control Switch

When this switch is pressed, the headlight flashes on to signal approaching cars or when passing.

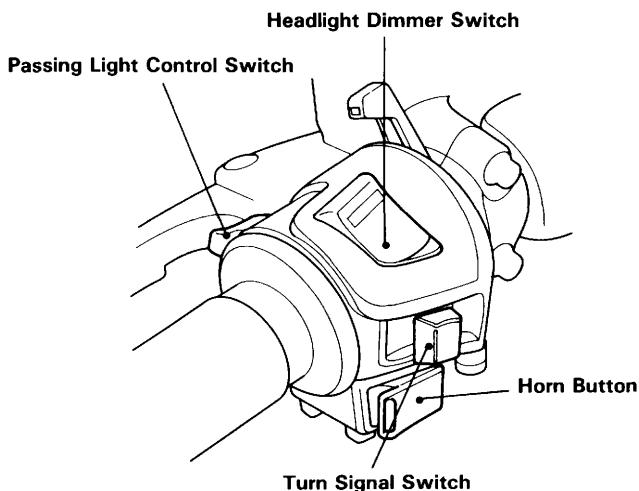

## **FEATURES (Not required for operation)**

---

### **STEERING LOCK**

To lock the steering, turn the handlebars all the way to the left or right, turn the key to LOCK while pushing in. Remove the key.

#### **▲ WARNING**

- ***Do not turn the key to LOCK while riding the motorcycle; loss of vehicle control may result.***

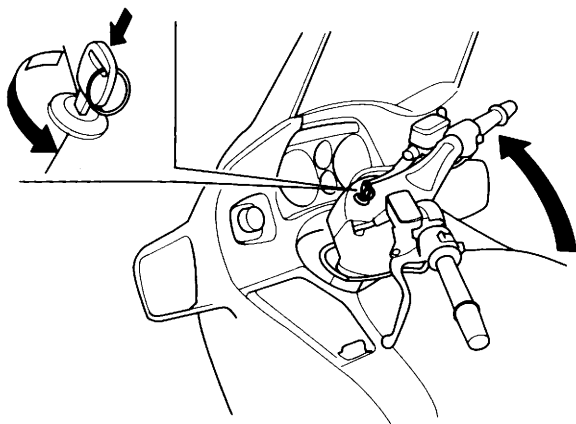

### **SEAT**

To remove the seat, insert the ignition key into the lock and turn it clockwise.

#### **CAUTION:**

- ***Be sure to securely lock the seat after installing it.***

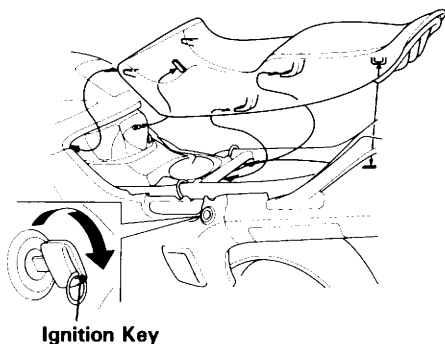

---

## HELMET HOLDERS

The helmet holders are under the seat.

Remove the seat (page 36). Hang your helmet(s) on the holder pin. Install the seat.

### ▲ WARNING

- ***The helmet holder is designed for helmet security while parked. Do not ride with a helmet attached to the holder; the helmet may interfere with safe operation and result in loss of control.***

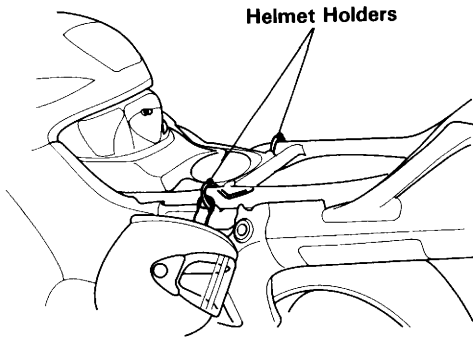

## CORD HOOKS

Use the cord hooks to fasten cargo.

The cord hooks are under the seat.

Remove the seat (page 36). Open the hook and install the seat.

### CAUTION:

- ***Never use the cord hook to tow or lift the motorcycle.***

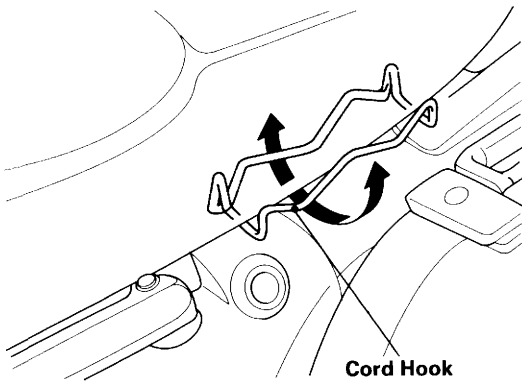

## **FEATURES (Not required for operation)**

### **DOCUMENT COMPARTMENT**

The document compartment is behind the seat.

The owners manual and other documents should be stored in the plastic bag.

#### **NOTE:**

- When washing your motorcycle, be careful not to flood this area with water.

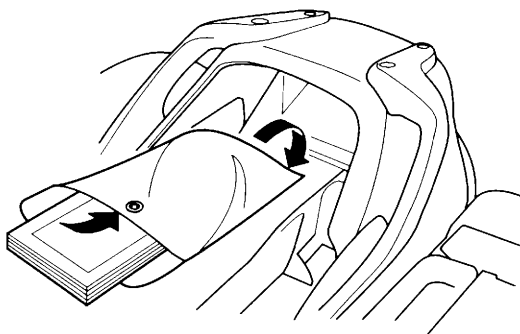

---

## SADDLEBAGS

To open the saddlebags:

Insert the ignition key and turn it counterclockwise to open the saddlebag.

To lock the saddlebags:

Close the saddlebags and turn the ignition key clockwise. Make sure the saddlebags are locked.

### ⚠ WARNING

- **The saddlebag is for lightweight items. Do not carry more than 9 kg (20 lbs) in each side. Excessive weight may adversely affect vehicle handling and control.**
- **Load weight equally in both sides to minimize an imbalance that may result in a loss of vehicle control.**
- **Review Loading and Accessories (page 3) before loading.**

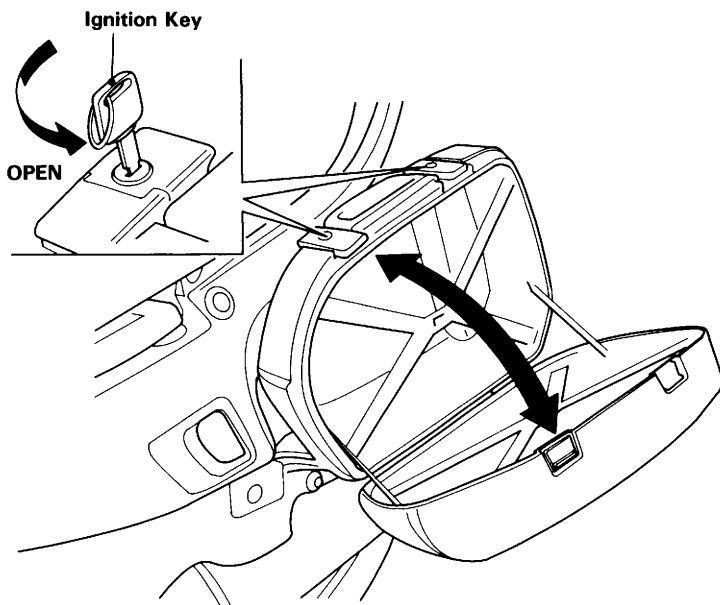

## **FEATURES (Not required for operation)**

To remove the saddlebags:

Insert the ignition key and turn it counterclockwise to open the latch lever. Remove the saddlebag by sliding it backward ①, lifting up ② and pulling it out toward you ③ as shown.

**NOTE:**

- After removing, lock the latch lever with ignition key.
- Do not remove the protective tapes from the rear cowl and saddlebags when removing the saddlebags.

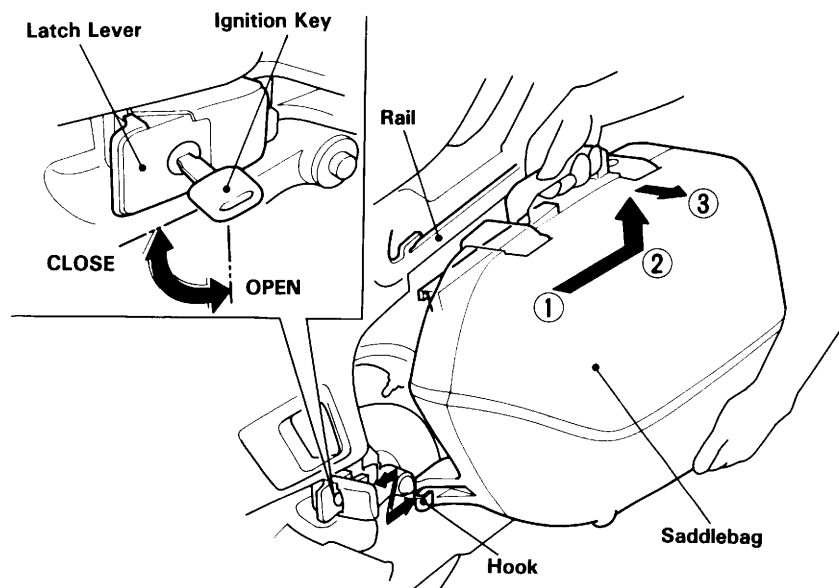

To install the saddlebags:

- Reverse the removal procedure.
- After installing the saddlebags, check that the hooks engage securely.
- Close the latch lever and turn the ignition key clockwise.

**NOTE:**

- Make sure the latch levers are locked before riding.

---

## FAIRING POCKETS

The fairing pockets are located on both side.

To open the left pocket lid, by pulling up the knob.

To remove the right pocket lid, insert the ignition key, turn it clockwise and open the lid.

### NOTE:

- Make sure the fairing pockets are closed before riding.
- When washing your motorcycle, be careful not to flood this area with water.

### ⚠ WARNING

- ***Fairing pockets are for lightweight items. Do not carry more than 2 kg (5 lbs) in each side. Excessive weight may adversely affect vehicle handling and control.***
- ***Load weight equally in both sides to avoid and imbalance that may result in a loss of vehicle control.***
- ***Review Loading and Accessories before loading (page 3).***

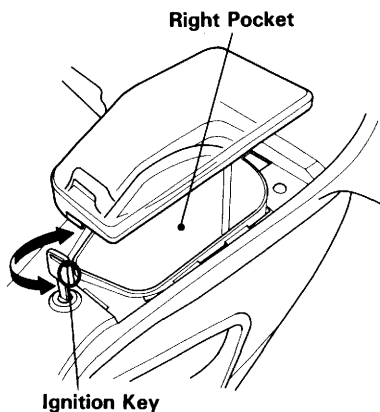
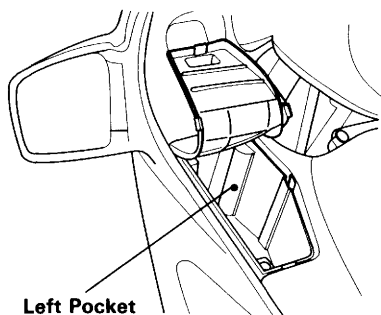

## **FEATURES (Not required for operation)**

### **REAR VIEW MIRROR COVERS**

Both rear view mirror covers use a special breakaway mount which allows a controlled separation of the mirror covers from its base upon impact with an obstacle. A short cable keeps the mirror covers connected to the mirror bracket.

#### **Installation:**

- Check the mirror for correct angle.
- Press on the mirror covers firmly until they click into position on the mirror mounts.
- After reinstalling, check the mirror for connect angle and the front turn signals for proper operation.

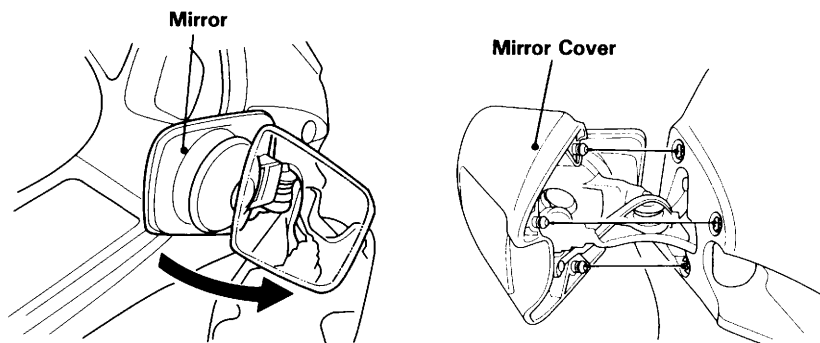

#### **CAUTION:**

- ***Riding with a mirror cover hanging by its retaining cable may damage the motorcycle's plastic body.***

#### **NOTE:**

- For your safety, be sure to immediately reassemble any separated mirror cover. Otherwise, the mirror and turnsignal will not be available to you while riding.

If a mirror cover is damaged so badly that it cannot be reused or reinstalled on its base, remove it from the base and transport the motorcycle to an authorized Honda dealer.

---

## HEADLIGHT BEAM ADJUSTMENT (Except G type)

The headlight beam can be raised or lowered by turning the vertical beam adjusting knob. Obey local laws and regulations concerning headlight adjustment.

**⚠ WARNING**

- ***Do not adjust the headlight beam while riding the motorcycle. Operating the motorcycle with one or both hands away from the handlebar/controls may result in a loss of vehicle control.***

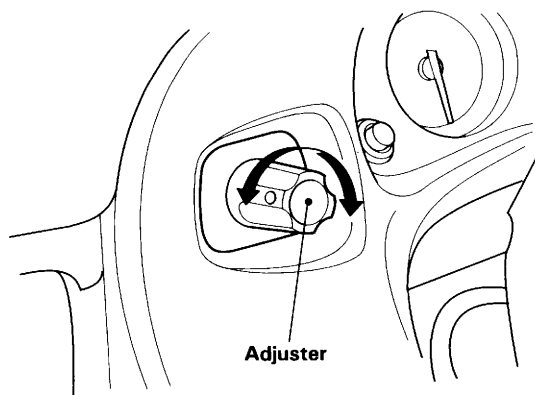

# OPERATION

---

## PRE-RIDE INSPECTION

### WARNING

- *If the Pre-ride Inspection is not performed, severe personal injury or vehicle damage may result.*

Inspect your motorcycle every day before you ride. The items listed here will only take a few minutes to inspect, and in the long run they can save time, expense, and possibly your life.

1. Engine oil level—add engine oil if required (page 27). Check for leaks.
2. Fuel level—fill fuel tank when necessary (page 24). Check for leaks.
3. Coolant level—add coolant if required. Check for leaks (pages 22—23).
4. Front and rear brakes—check operation; make sure there is no brake fluid leakage. (pages 18—20, 86)
5. Tires—check condition (pages 28—30) and pressure (page 30).
6. Throttle—check for smooth opening and full closing in all steering positions.
7. Lights and horn—check that headlight, tail/brake light, turn signals, indicators and horn function properly.
8. Engine stop switch—check for proper function (page 34).
9. Side stand ignition cut-off system—check for proper function (page 87).

Correct any discrepancy before you ride. Contact your authorized Honda dealer for assistance if you cannot correct the problem.

---

## STARTING THE ENGINE

This motorcycle is equipped with a side stand ignition cut-off system. The engine cannot be started if the side stand is down, unless the transmission is in neutral. If the side stand is up, the engine can be started in neutral or in gear with the clutch lever pulled in. After starting with the side stand down, the engine will stop if the transmission is put in gear before raising the side stand.

### **▲ WARNING**

- ***Never run the engine in an enclosed area. The exhaust contains poisonous carbon monoxide gas that can cause loss of consciousness and lead to death.***
- ***Do not flood the engine by twisting the throttle repeatedly. The carburetor has an accelerator pump.***

### NOTE:

- Do not use the electric starter for more than 5 seconds at a time. Release the starter button for approximately 10 seconds before pressing it again.

### Preparation

Before starting, insert the key, turn the ignition switch ON and confirm the following:

- The transmission is in NEUTRAL (neutral indicator light ON).
- The engine stop switch is at RUN.
- The ABS Warning Light, TCS Warning Light, TCS OFF Indicator and TCS Activation Light are ON (For Some Types). (See pages 13—14).
- The red engine oil pressure warning light is ON.

### CAUTION:

- ***The red oil pressure warning light should go off a few seconds after the engine starts. If the light stays on, stop the engine immediately and check engine oil level. Operating the engine with insufficient oil pressure can cause serious engine damage.***

# OPERATION

---

## Starting Procedure

1. Pull the choke lever to the fully ON (B) position, if the engine is cold.
2. Press the starter button.
3. Warm up the engine until it runs smoothly with the choke OFF (A).

### NOTE:

- Do not open the throttle when starting the engine with the choke on. This will lean the mixture, resulting in hard starting.

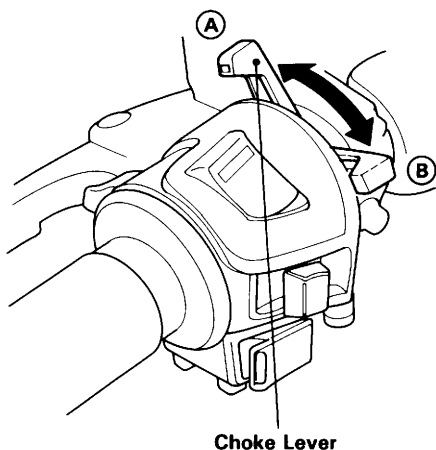

### CAUTION:

- *Extended use of the choke may impair piston and cylinder wall lubrication.*

## Flooded Engine

If the engine fails to start after repeated attempts, it may be flooded with excess fuel. To clear a flooded engine, turn the engine stop switch OFF and push the choke lever up to Fully Off (A). Open the throttle fully and crank the engine for 5 seconds. Wait 10 seconds, then turn the engine stop switch ON and follow the Starting Procedure.

---

## **BREAK-IN**

During initial break-in, newly machined surfaces will be in contact with each other and these surfaces will wear in quickly. Break-in maintenance at 1,000 km (600 miles) is designed to compensate for this initial minor wear. Timely performance of break-in maintenance will ensure optimum service life and performance from the engine.

The general rules are as follows:

1. Never lug the engine with full throttle at low engine speeds. This rule is applicable not only during break-in but at all times.
2. Maximum continuous engine speed during the first 1,000 km (600 miles) must not exceed 4,000 rpm.
3. Increase the maximum continuous engine speed by 1,000 rpm between odometer readings of 1,000 km (600 miles) and 1,600 km (1,000 miles). Drive briskly, vary speeds frequently and use full throttle for short bursts only. Do not exceed 6,000 rpm.
4. Upon reaching an odometer reading of 1,600 km (1,000 miles), you can subject the motorcycle to full throttle operation. However, do not exceed 8,000 rpm at any time (tachometer red zone limit).

### **CAUTION:**

- *The red bar indicates the maximum limit of engine speed and running the engine in the red bar will adversely affect its service life.*

# OPERATION

---

## RIDING

Review Motorcycle Safety (pages 1—5) before you ride.

### NOTE:

- Make sure the function of the side stand mechanism (See MAINTENANCE SCHEDULE on page 61 and explanation for SIDE STAND on page 87.)

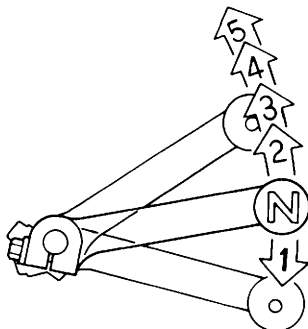

Proper shifting will provide better fuel economy.

### **▲ WARNING**

- ***Do not downshift when traveling at a speed that would force the engine to overrev in the next lower gear; the rear wheel may lose traction, resulting in a possible loss of vehicle control.***

### CAUTION:

- ***Do not shift gears without disengaging the clutch and closing the throttle. The engine and drive train could be damaged by overspeed and shock.***
- ***Do not tow the motorcycle or coast for long distances while the engine is off. The transmission will not be properly lubricated and damage may result.***
- ***Do not run the engine at high rpm with the transmission in neutral or the clutch lever pulled in. Serious engine damage may result.***

### NOTE:

- Be careful when revving the engine or accelerating in 1st or 2nd gear as the engine speed will easily enter the red bar.

---

## BRAKING

1. For normal braking, gradually apply both the front and rear brakes while downshifting to suit your road speed.
2. For maximum deceleration, close the throttle and apply the front and rear brakes firmly. Pull in the clutch lever before coming to a complete stop to prevent stalling the engine.

### **▲ WARNING**

- *Independent operation of only the brake lever or brake pedal reduces stopping performance.*
- *Extreme application of the brake controls may cause wheel lock, reducing control of the motorcycle.*
- *When possible, reduce speed or brake before entering a turn; closing the throttle or braking in mid-turn may cause wheel slip. Wheel slip will reduce control of the motorcycle.*
- *When riding in wet or rainy conditions, or on loose surfaces, the ability to maneuver and stop will be reduced. All of your actions should be smooth under these conditions. Sudden acceleration, braking or turning may cause loss of control. For your safety, exercise extreme caution when braking, accelerating or turning.*
- *When descending a long, steep grade, use engine compression braking by downshifting, with intermittent use of both brakes. Continuous brake application can overheat the brakes and reduce their effectiveness.*
- *Riding with your foot resting on the brake pedal or your hand on the brake lever may actuate the brakelight, giving a false indication to other drivers. It may also overheat the brakes, reducing effectiveness.*

# OPERATION

---

## ANTI-LOCK BRAKE SYSTEM (ABS)

### (For Some Types)

The Anti-lock Brake System (ABS) is designed to help prevent wheel lock up during hard braking or during braking on uneven surfaces while running straight.

ABS cannot make up for road conditions, bad judgement, or improper operation of the brakes. It is still your responsibility to ride at reasonable speeds for weather, road surface, and traffic conditions, and to leave a margin of safety.

ABS is self-checking and is always ON. You may feel a pulsing in the brake lever or pedal or hear the sound of a small electric motor right after starting the engine. This is normal. It indicates that the system is checking itself.

#### WARNING

- ***Though your motorcycle is equipped with ABS, avoid driving on snow-covered road, frozen surface, etc.***
- ***In some situations, a motorcycle with ABS may require a longer stopping distance to stop on loose or uneven surfaces than an equivalent motorcycle without ABS.***

#### NOTE:

- You may hear the sound of a small electric motor when the ABS is active.
- ABS may be activated by riding over a sharp drop or rise in the road level.

You may feel a pulsation in the brake pedal and lever when you operate the brake system. This is normal indicating that the ABS is active. While, you may not feel a pulsation in the brake pedal and lever according to the road condition. This is normal, too.

## NOTE

- It is important to follow the tire recommendations (see page 30). The ABS computer works by comparing wheelspeed. Non-recommended tires can affect wheelspeed and may confuse the ABS computer.
- ABS does not function at low speeds (approximately 7 km/h or below).
- The ABS does not function if the battery is discharged.

## ABS Warning Light

Normally, this light comes on when the ignition is turned ON and goes off after starting to ride (see page 14). If there is an ABS problem, the warning light comes on — or blinks. The system does not operate when the ABS warning light is ON or blinking.

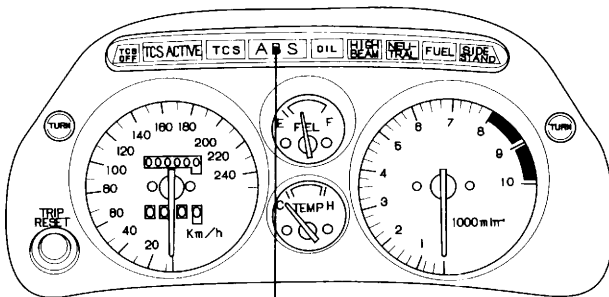

ABS Warning Light

## OPERATION

---

If the ABS warning light blinks while riding, stop the motorcycle in a safe place and turn off the engine.

Turn the ignition ON again. The light should come on, and then go off after starting to ride. If it does not go off or if it blinks again, ABS is not functioning, but the brakes still work like a conventional system and provide normal stopping ability. However, you should have the system checked by an authorized Honda dealer as soon as possible.

### NOTE

- The ABS warning light may blink if you turn the rear wheel placing the motorcycle upright on the stand. This is normal. Turn the ignition OFF to stop the blinking.

### CAUTION

- ***Two LED bulbs are used for the ABS warning light. Be sure that both bulbs light when the ignition is ON. If either or both bulbs fail to light, See your authorized Honda dealer.***

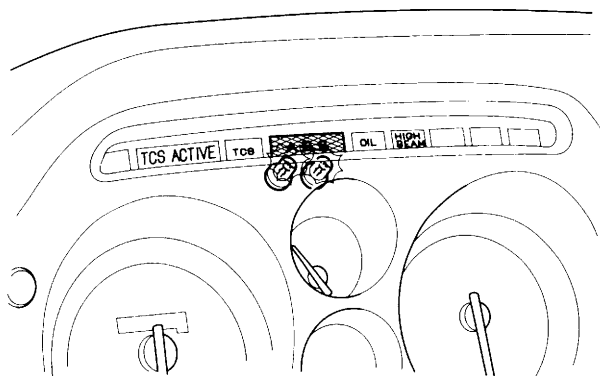

---

## ABS/TCS Warning Light Switch

To dim the intensity of the blinking ABS Warning Light, push the ABS/TCS Warning Light Switch.

### **⚠ WARNING**

- ***Do not operate the switch while riding the motorcycle. Operating the motorcycle with one or both hands away from the handlebar/controls may result in a loss of vehicle control.***

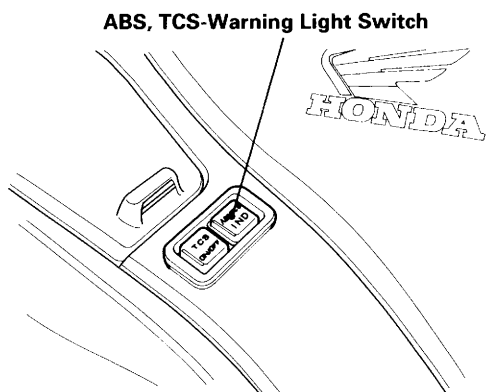

# OPERATION

## TRACTION CONTROL SYSTEM (TCS)

(For Some Type)

The traction control system (TCS) assists you in maintaining traction by regulating the spinning force of the rear wheel that is often caused by change in the road surface while running straight. When riding on loose, slippery, or uneven surfaces, you may notice the engine does not respond to the throttle in the same way it usually does. This is a sign that TCS is activated and operating. The TCS Activation Light will turn on to signal you. Once you know TCS is active, reduce your throttle input and ride with extra care.

The TCS automatically placed in the ON mode when the ignition is ON.

The TCS is the system that assists you in throttle operation and it does not make up for a rough driving. It is still your responsibility to ride at reasonable speeds and to leave a sufficient margin of safety.

### ⚠ WARNING

- ***Though your motorcycle is equipped with TCS, avoid driving on snow-covered road, frozen surface, etc.***

### NOTE:

- Engine intake and exhaust noise may change when the TCS is active.
- TCS may be activated by riding over a sharp drop or rise in the road level.

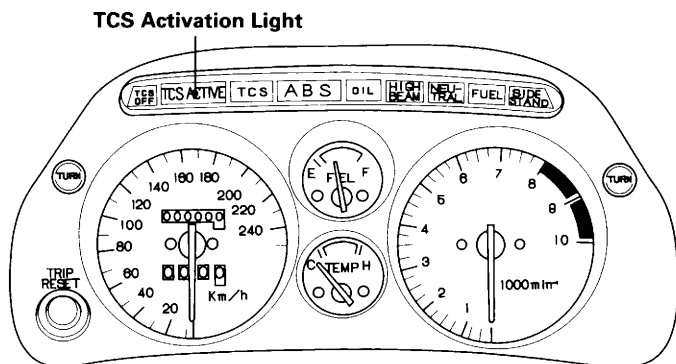

## TCS ON/OFF SWITCH

This switch lets you turn TCS ON or OFF. When the TCS ON/OFF switch is pushed with the ignition turned ON, the TCS turns OFF and the TCS OFF indicator in the instrument panel turns ON. When the switch is pushed again, the TCS turns ON and the TCS OFF indicator turns OFF.

The TCS repeats ON and OFF alternately when the switch is pushed.

### ⚠ WARNING

- **Do not operate the switch while riding the motorcycle.**  
**Operating the motorcycle with one or both hands away from the handlebar/controls may result in a loss of vehicle control.**

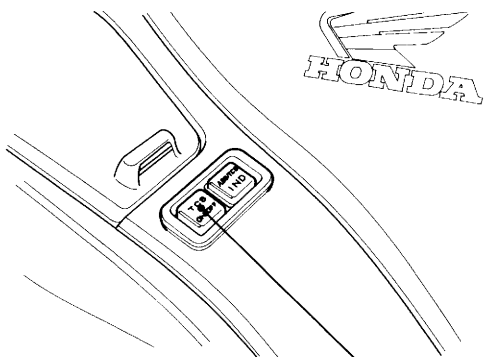

TCS ON/OFF SWITCH

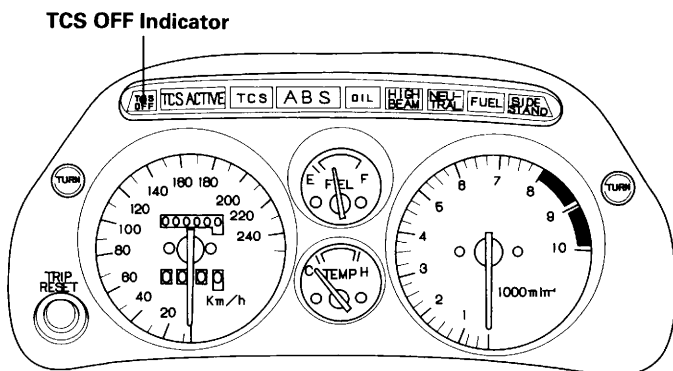

TCS OFF Indicator

# OPERATION

## TCS Warning Light

Normally, this light comes on when the ignition is turned ON and goes off after starting to ride (see page 14). If there is an TCS problem, the warning light comes on and remains on — or blinks. The system does not operate when the TCS warning light is ON or blinking.

If the TCS warning light blinks while riding, stop the motorcycle in a safe place and turn off the engine.

Turn the ignition ON again. The light should come on, and then go off after starting to ride. If it does not go off or if it blinks again, the TCS is not functioning, you can drive the motorcycle without TCS. However, have the system checked by an authorized Honda dealer as soon as possible.

### NOTE:

- When the TCS warning light blinks, the TCS is automatically disabled and the TCS OFF indicator turns on.
- The TCS warning light may blink if you turn the rear wheel placing the motorcycle upright on the stand. This is normal. Turn the ignition OFF to stop the blinking.

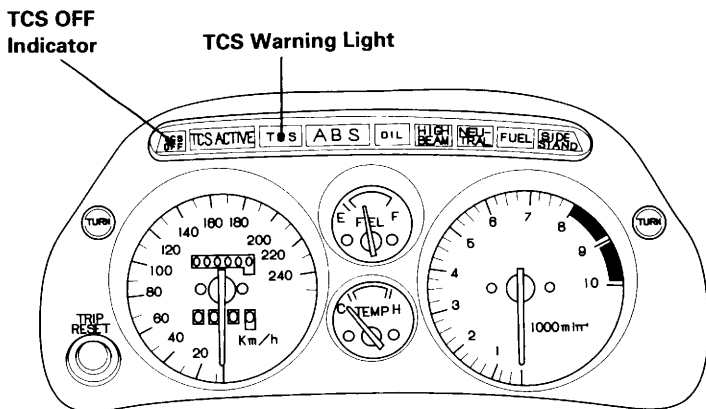

---

## ABS/TCS Warning Light Switch

To turn off the blinking TCS Warning Light, push the ABS/TCS Warning Light Switch.

### WARNING

- ***Do not operate the switch while riding the motorcycle. Operating the motorcycle with one or both hands away from the handlebar/controls may result in a loss of vehicle control.***

### NOTE:

- The TCS OFF indicator remains ON after the TCS warning light is OFF.

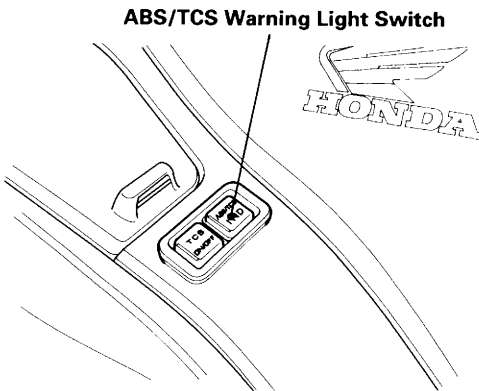

# OPERATION

---

## PARKING

1. After stopping the motorcycle, shift the transmission into neutral, turn the ignition switch OFF and remove the key.
2. Use the side or center stand to support the motorcycle while parked.

## CAUTION:

- ***Park the motorcycle on firm, level ground to prevent it from falling over.***

3. Lock the steering to help prevent theft (page 34).

## NOTE: <AR type>

- When stopping for a short time near traffic at night, the ignition switch may be turned to P and the key removed. This will turn on the taillight to make the motorcycle more visible to traffic. The battery will discharge if the ignition switch is left at P for too long a time.

## ANTI-THEFT TIPS

1. Always lock the steering and never leave the key in the ignition switch. This sounds simple but people do forget.
2. Be sure the registration information for your motorcycle is accurate and current.
3. Park your motorcycle in a locked garage whenever possible.
4. Use an additional anti-theft device of good quality.
5. Put your name, address, and phone number in this Owner's Manual and keep it on your motorcycle at all times. Many times stolen motorcycles are identified by information in the Owner's Manuals that are still with them.

NAME: \_\_\_\_\_

ADDRESS: \_\_\_\_\_

\_\_\_\_\_

PHONE NO: \_\_\_\_\_

## **MAINTENANCE**

---

- When service is required, remember that your authorized Honda dealer knows your motorcycle best and is fully equipped to maintain and repair it. The scheduled maintenance and the anticipated maintenance may also be performed by a qualified service facility that normally does this kind of work; or you may perform most of the work yourself if you are mechanically qualified and have the proper tools and service data.
- These instructions are based on the assumption that the motorcycle will be used exclusively for its designed purpose. Sustained high speed operation or operation in unusually wet or dusty conditions will require more frequent service than specified in the MAINTENANCE SCHEDULE. Consult your authorized Honda dealer for recommendations applicable to your individual needs and use.

# MAINTENANCE

## MAINTENANCE SCHEDULE

Perform the Pre-ride Inspection (page 44) at each scheduled maintenance period.

I : INSPECT AND CLEAN, ADJUST, LUBRICATE OR REPLACE IF NECESSARY

C: CLEAN R: REPLACE A: ADJUST L: LUBRICATE

The following items require some mechanical knowledge. Certain items (particularly those marked \* and \*\*) may require more technical information and tools. Consult your authorized Honda dealer.

FREQUENCY		WHICHEVER →	ODOMETER READING (NOTE 1)								Refer to page
			COMES FIRST ↓	×1,000 km	1	6	12	18	24	30	
		NOTE	×1,000 mi	0.6	4	8	12	16	20	24	
			MONTHS		6	12	18	24	30	36	
*	FUEL LINE					I		I		I	
*	THROTTLE OPERATION					I		I		I	
*	CARBURETOR CHOKE					I		I		I	
	AIR CLEANER	NOTE 2					R			R	73-74
	SPARK PLUGS			I	R	I	R	I	R		75-76
*	VALVE CLEARANCE			I				I			
	ENGINE OIL			R		R		R		R	70
	ENGINE OIL FILTER			R		R		R		R	71
*	CARBURETOR SYNCHRONIZATION			I		I		I		I	
*	CARBURETOR IDLE SPEED			I	I	I	I	I	I	I	
	RADIATOR COOLANT	NOTE 3				I		I		R	22-23
*	COOLING SYSTEM					I		I		I	
*	SECONDARY AIR SUPPLY SYSTEM	NOTE 4				I		I		I	
**	TIMING BELT										EVERY 100.000 km (60.000 mi) I EVERY 150.000 km (90.000 mi) R

ITEM	FREQUENCY	WHICHEVER → COMES FIRST ↓ NOTE	ODOMETER READING (NOTE 1)								Refer to page
			×1,000 km	1	6	12	18	24	30	36	
			×1,000 mi	0.6	4	8	12	16	20	24	
		MONTHS		6	12	18	24	30	36		
FINAL DRIVE OIL									R	29, 78	
BRAKE FLUID		NOTE 3					R			R	18
BRAKE PAD WEAR											18-20, 86
BRAKE SYSTEM											18-20, 86
* BRAKE LIGHT SWITCH											
* HEADLIGHT AIM											
CLUTCH SYSTEM											21
CLUTCH FLUID		NOTE 3					R			R	21
SIDE STAND											87
* SUSPENSION											
* NUTS, BOLTS, FASTENERS											
** WHEELS/TIRES											
** STEERING HEAD BEARINGS											

- \* SHOULD BE SERVICED BY AN AUTHORIZED HONDA DEALER, UNLESS THE OWNER HAS PROPER TOOLS AND SERVICE DATA AND IS MECHANICALLY QUALIFIED. REFER TO THE OFFICIAL HONDA SERVICE MANUAL.
- \*\* IN THE INTEREST OF SAFETY, WE RECOMMEND THESE ITEMS BE SERVICED ONLY BY AN AUTHORIZED HONDA DEALER.

NOTES: 1. At higher odometer readings, repeat at the frequency interval established here.

2. Service more frequently when riding in unusually wet or dusty areas.

3. Replace every 2 years, or at indicated odometer interval, whichever comes first. Replacement requires mechanical skill.

4. Switzerland type only.

# MAINTENANCE

---

## TOOL KIT

The tool kit is in the right fairing pocket. Open the right fairing pocket (page 41). Some roadside repairs, minor adjustments and parts replacement can be performed with the tools contained in the kit.

- Spark plug wrench
- 10 × 12 mm Box end wrench
- 14 mm Box end wrench
- 22 mm Box end wrench
- 27 mm Box end wrench
- 8 mm Open end wrench
- 10 × 12 mm Open end wrench
- 14 × 17 mm Open end wrench
- Pliers
- Screwdriver handle
- Screwdriver
- Pin spanner
- Pin spanner grip
- 5 mm Hex wrench
- 6 mm Hex wrench
- Tool bag

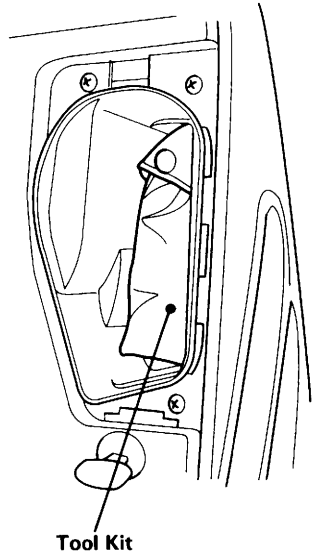

---

## SERIAL NUMBERS

The frame and engine serial numbers are required when registering your motorcycle. They may also be required by your dealer when ordering replacement parts.

Record the numbers here for your reference.

The frame number is stamped on the right side of the steering head.

The engine number is stamped on the rear of the lower crankcase behind the oil pan.

## COLOR LABEL

The color label is attached to the frame under the seat. It is helpful when ordering replacement parts. Record the color and code here for your reference.

FRAME NO. \_\_\_\_\_

ENGINE NO. \_\_\_\_\_

COLOR \_\_\_\_\_

CODE \_\_\_\_\_

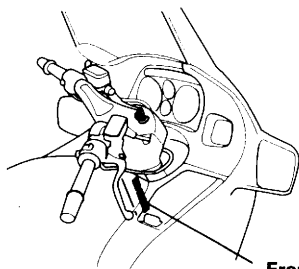

Frame Number

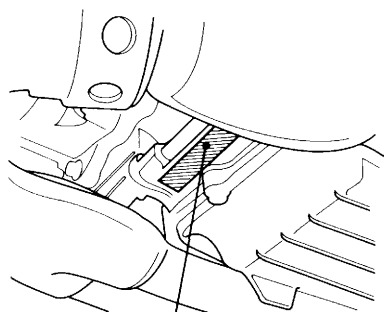

Engine Number

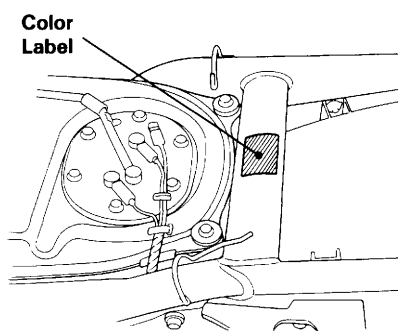

Color Label

# MAINTENANCE

---

## MAINTENANCE PRECAUTIONS

### **▲ WARNING**

- *If your motorcycle is overturned or involved in a collision, inspect control levers, cables, brake hoses, calipers, accessories, and other vital parts for damage. Do not ride the motorcycle if damage impairs safe operation. Have your authorized Honda dealer inspect the major components, including frame, suspension and steering parts, for misalignment and damage that you may not be able to detect.*
- *Stop the engine and support the motorcycle securely on a firm, level surface before performing any maintenance.*
- *Use new, genuine Honda parts or their equivalent for maintenance and repair. Parts which are not of equivalent quality may impair the safety of your motorcycle and the effective operation of the emission control systems.*

---

## COVER REMOVAL

(Right side shown; left side similar)

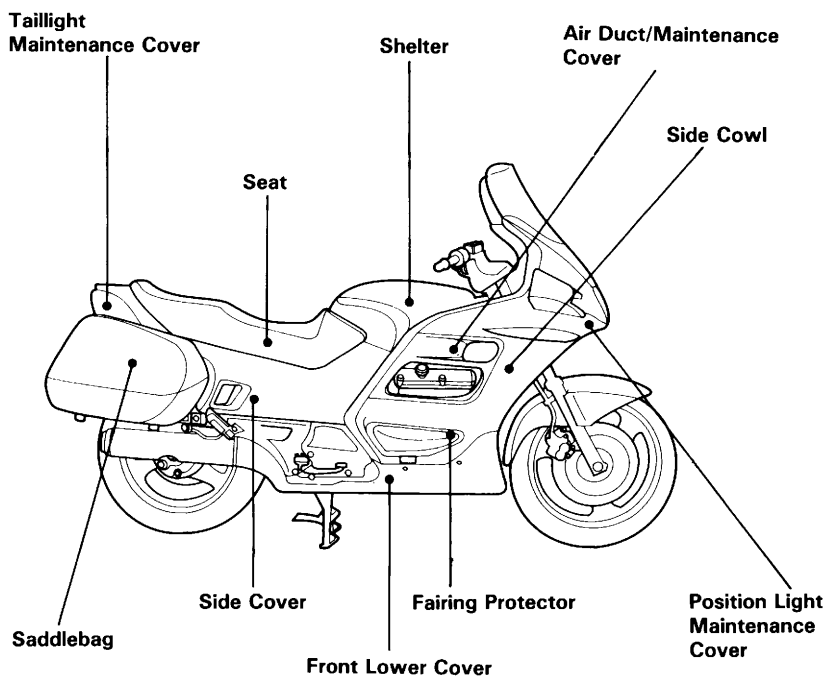

# MAINTENANCE

---

- Side Cover

1. Remove the saddlebag (see page 40)
2. Remove the seat (see page 36)
3. Remove the screw. Pull the rear of the cover first, then rotate it clockwise and pull the front of the cover.

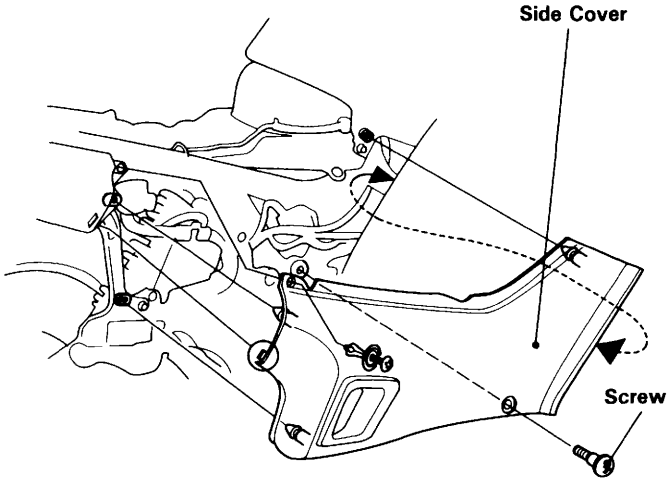

- Air Duct/Maintenance Cover

Remove the bolts, pull the cover out, then slide it to the rear.

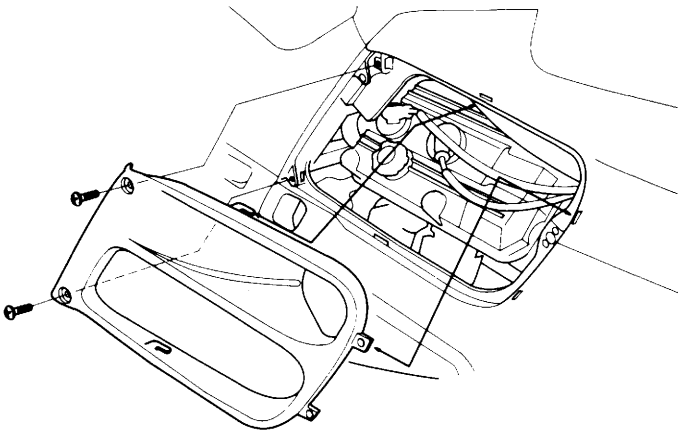

---

- Shelter

1. Remove the seat (see page 36).
2. Remove the shelter by removing bolts.

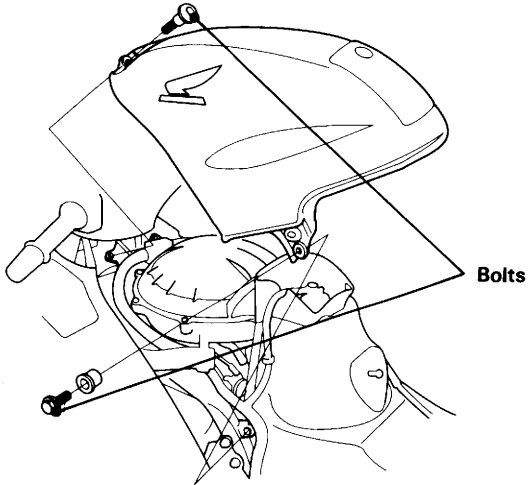

- Front Lower Cover

Remove the bolts then slide the cover forward.

**NOTE:**

- Use the short collar bolt in the right rear hole when installing the under cowl.

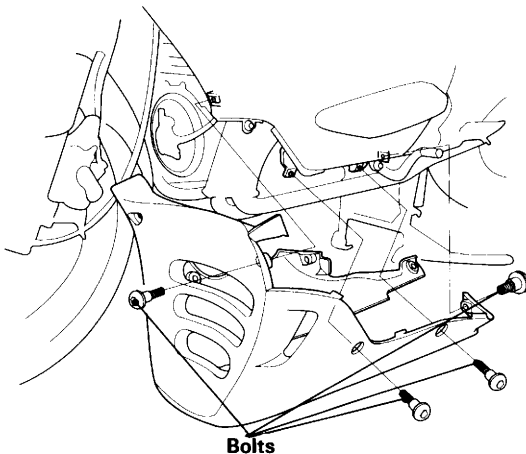

# MAINTENANCE

---

- Position light Maintenance Cover  
Remove the screws, then slide the cover to the rear.

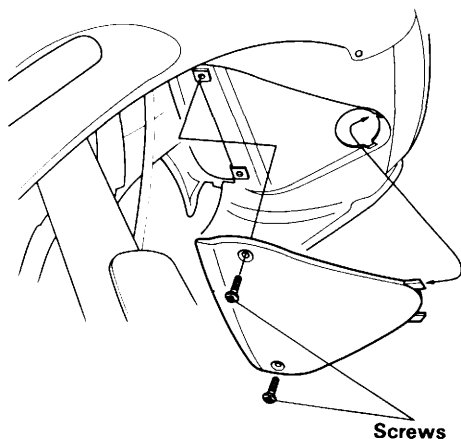

- Taillight Maintenance Cover  
Push the triangular flaps of the document compartment in and backward against the sides of the document compartment ①. Pull up on the rear of the document compartment toward the front ②.

