

 **HONDA**

OWNER'S MANUAL



VT750C2/C2F-9

Honda VT750C2/C2F

OWNER'S MANUAL

© Honda Motor Co., Ltd. 2008

IMPORTANT INFORMATION

- **OPERATOR AND PASSENGER**

This motorcycle is designed to carry the operator and one passenger. Never exceed the maximum weight capacity as shown on the accessories and loading label.

- **ON-ROAD USE**

This motorcycle is designed to be used only on the road.

- **READ THIS OWNER'S MANUAL CAREFULLY**

Pay special attention to the safety messages that appear throughout the manual. These messages are fully explained in the "A Few Words About Safety" section which appears before the Contents page.

This manual should be considered a permanent part of the motorcycle and should remain with the motorcycle when resold.

Honda VT750C2/C2F OWNER'S MANUAL

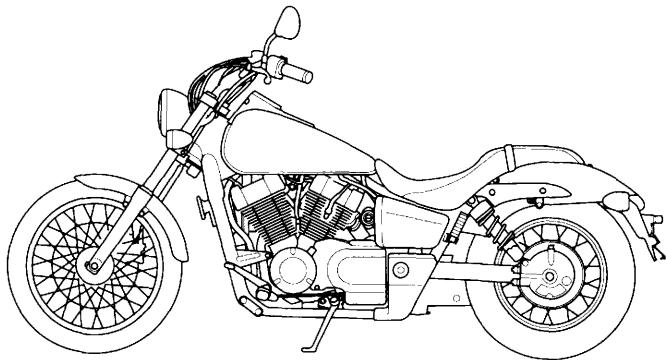

All information in this publication is based on the latest production information available at the time of approval for printing. Honda Motor Co.,Ltd. reserves the right to make changes at any time without notice and without incurring any obligation.

No part of this publication may be reproduced without written permission.

WELCOME

The motorcycle presents you a challenge to master the machine, a challenge to adventure. You ride through the wind, linked to the road by a vehicle that responds to your commands as no other does. Unlike an automobile, there is no metal cage around you. Like an airplane, a pre-ride inspection and regular maintenance are essential to your safety. Your reward is freedom.

To meet the challenges safely, and to enjoy the adventure fully, you should become thoroughly familiar with this owner's manual BEFORE YOU RIDE THE MOTORCYCLE.

As you read this manual, you will find information that is preceded by a **NOTICE** symbol. This information is intended to help you avoid damage to your motorcycle, other property, or the environment.

When service is required, remember that your Honda dealer knows your motorcycle best. If you have the required mechanical "know-how" and tools, your dealer can supply you with an official Honda Shop Manual to help you perform many maintenance and repair tasks.

Pleasant riding, and thank you for choosing a Honda !

- The following codes in this manual indicate each country.

U	Australia	New Zealand
---	-----------	-------------

- The specifications may vary with each locale.

A FEW WORDS ABOUT SAFETY

Your safety, and the safety of others, is very important. And operating this motorcycle safely is an important responsibility.

To help you make informed decisions about safety, we have provided operating procedures and other information on labels and in this manual. This information alerts you to potential hazards that could hurt you or others.

Of course, it is not practical or possible to warn you about all hazards associated with operating or maintaining a motorcycle. You must use your own good judgment.

You will find important safety information in a variety of forms, including:

- **Safety Labels** — on the motorcycle.
- **Safety Messages** — preceded by a safety alert symbol  and one of three signal words: **DANGER, WARNING, or CAUTION.**

These signal words mean:

▲ DANGER

You **WILL** be **KILLED** or **SERIOUSLY HURT** if you don't follow instructions.

▲ WARNING

You **CAN** be **KILLED** or **SERIOUSLY HURT** if you don't follow instructions.

▲ CAUTION

You **CAN** be **HURT** if you don't follow instructions.

- **Safety Headings** — such as Important Safety Reminders or Important Safety Precautions.
- **Safety Section** — such as Motorcycle Safety.
- **Instructions** — how to use this motorcycle correctly and safely.

This entire manual is filled with important safety information — please read it carefully.

OPERATION

page

1 MOTORCYCLE SAFETY

- 1 IMPORTANT SAFETY INFORMATION
- 2 PROTECTIVE APPAREL
- 4 LOAD LIMITS AND GUIDELINES

8 PARTS LOCATION

- 11 INSTRUMENTS AND INDICATORS

17 MAJOR COMPONENTS

(Information you need to operate this motorcycle)

- 17 SUSPENSION
- 18 BRAKES
- 22 CLUTCH
- 24 COOLANT
- 26 FUEL
- 29 ENGINE OIL
- 30 FINAL DRIVE OIL
- 31 TYRES

page

36 ESSENTIAL INDIVIDUAL COMPONENTS

- 36 IGNITION SWITCH
- 37 KEYS
- 39 IMMOBILIZER SYSTEM (HISS)
- 42 RIGHT HANDLEBAR CONTROLS
- 43 LEFT HANDLEBAR CONTROLS

page

44 FEATURES

(Not required for operation)

- 44 STEERING LOCK
- 45 HELMET HOLDER
- 46 DOCUMENT BAG
- 47 SIDE COVER
- 48 SEAT
- 49 HEADLIGHT AIM VERTICAL
ADJUSTMENT

page

50 OPERATION

- 50 PRE-RIDE INSPECTION
- 51 STARTING THE ENGINE
- 54 RUNNING-IN
- 55 RIDING
- 57 BRAKING
- 58 PARKING
- 59 ANTI-THEFT TIPS

MAINTENANCE

page

60 MAINTENANCE

- 60 THE IMPORTANCE OF MAINTENANCE
- 61 MAINTENANCE SAFETY
- 62 SAFETY PRECAUTIONS
- 63 MAINTENANCE SCHEDULE
- 66 TOOL KIT
- 67 SERIAL NUMBERS
- 68 COLOUR LABEL
- 69 ENGINE OIL
- 74 CRANKCASE BREATHER
- 75 SPARK PLUGS
- 77 FINAL DRIVE OIL
- 78 THROTTLE OPERATION
- 79 COOLANT
- 80 AIR CLEANER
- 81 FRONT AND REAR SUSPENSION INSPECTION
- 82 SIDE STAND
- 83 WHEEL REMOVAL
- 92 BRAKE PAD WEAR
- 93 BRAKE SHOE WEAR

page

- 94 BATTERY
- 97 FUSE REPLACEMENT
- 100 BRAKELIGHT SWITCH ADJUSTMENT
- 101 BULB REPLACEMENT
- 106 CLEANING**
- 109 STORAGE GUIDE**
- 109 STORAGE
- 111 REMOVAL FROM STORAGE
- 112 TAKING CARE OF THE UNEXPECTED**
- 113 SPECIFICATIONS**
- 118 CATALYTIC CONVERTERS**

MOTORCYCLE SAFETY

IMPORTANT SAFETY INFORMATION

Your motorcycle can provide many years of service and pleasure – if you take responsibility for your own safety and understand the challenges that you can meet on the road.

There is much that you can do to protect yourself when you ride. You'll find many helpful recommendations throughout this manual. Following are a few that we consider to be most important.

Always Wear a Helmet

It's a proven fact: helmets significantly reduce the number and severity of head injuries. So always wear an approved motorcycle helmet and make sure your passenger does the same. We also recommend that you wear eye protection, sturdy boots, gloves, and other protective gear (page 2).

Make Yourself Easy to See

Some drivers do not see motorcycles because they are not looking for them. To make yourself more visible, wear bright reflective clothing, position yourself so other drivers can see you, signal before turning or changing lanes, and use your horn when it will help others notice you.

Ride Within Your Limits

Pushing the limits is another major cause of motorcycle accidents. Never ride beyond your personal abilities or faster than conditions warrant. Remember that alcohol, drugs, fatigue and inattention can significantly reduce your ability to make good judgements and ride safely.

Don't Drink and Ride

Alcohol and riding don't mix. Even one drink can reduce your ability to respond to changing conditions, and your reaction time gets worse with every additional drink. So don't drink and ride, and don't let your friends drink and ride either.

Keep Your Bike in Safe Condition

For safe riding, it's important to inspect your motorcycle before every ride and perform all recommended maintenance. Never exceed load limits, and only use accessories that have been approved by Honda for this motorcycle. See page 4 for more details.

PROTECTIVE APPAREL

For your safety, we strongly recommend that you always wear an approved motorcycle helmet, eye protection, boots, gloves, long pants, and a long-sleeved shirt or jacket whenever you ride. Although complete protection is not possible, wearing proper gear can reduce the chance of injury when you ride.

Following are suggestions to help you choose proper gear.

WARNING

Not wearing a helmet increases the chance of serious injury or death in a crash.

Be sure you and your passenger always wear a helmet, eye protection and other protective apparel when you ride.

Helmets and Eye Protection

Your helmet is your most important piece of riding gear because it offers the best protection against head injuries. A helmet should fit your head comfortably and securely. A bright-coloured helmet can make you more noticeable in traffic, as can reflective strips.

An open-face helmet offers some protection, but a full-face helmet offers more. Always wear a face shield or goggles to protect your eyes and help your vision.

Additional Riding Gear

In addition to a helmet and eye protection, we also recommend:

- Sturdy boots with non-slip soles to help protect your feet and ankles.
- Leather gloves to keep your hands warm and help prevent blisters, cuts, burns and bruises.
- A motorcycle riding suit or jacket for comfort as well as protection. Bright-coloured and reflective clothing can help make you more noticeable in traffic. Be sure to avoid loose clothes that could get caught on any part of your motorcycle.

LOAD LIMITS AND GUIDELINES

Your motorcycle has been designed to carry you and one passenger. When you carry a passenger, you may feel some difference during acceleration and braking. But so long as you keep your motorcycle well-maintained, with good tyres and brakes, you can safely carry loads within the given limits and guidelines.

However, exceeding the weight limit or carrying an unbalanced load can seriously affect your motorcycle's handling, braking and stability. Non-Honda accessories, improper modifications, and poor maintenance can also reduce your safety margin.

The following pages give more specific information on loading, accessories and modifications.

Loading

How much weight you put on your motorcycle, and how you load it, are important to your safety. Anytime you ride with a passenger or cargo you should be aware of the following information.

WARNING

Overloading or improper loading can cause a crash and you can be seriously hurt or killed.

Follow all load limits and other loading guidelines in this manual.

Load Limits

Following are the load limits for your motorcycle:

Maximum weight capacity:

191 kg (421 lbs)

Includes the weight of the rider, passenger, all cargo and all accessories

Maximum cargo weight:

18 kg (40 lbs)

The weight of added accessories will reduce the maximum cargo weight you can carry.

Loading Guidelines

Your motorcycle is primarily intended for transporting you and a passenger. You may wish to secure a jacket or other small items to the seat when you are not riding with a passenger.

If you wish to carry more cargo, check with your Honda dealer for advice, and be sure to read the information regarding accessories on page 7 .

Improperly loading your motorcycle can affect its stability and handling. Even if your motorcycle is properly loaded, you should ride at reduced speeds and never exceed 130 km/h (80 mph) when carrying cargo.

Follow these guidelines whenever you carry a passenger or cargo:

- Check that both tyres are properly inflated (page 31).
- If you change your normal load, you may need to adjust the rear suspension (page 17).
- To prevent loose items from creating a hazard, make sure that all cargo is securely tied down before you ride away.
- Place cargo weight as close to the center of the motorcycle as possible.
- Balance cargo weight evenly on both sides.

Accessories and Modifications

Modifying your motorcycle or using non-Honda accessories can make your motorcycle unsafe. Before you consider making any modifications or adding an accessory, be sure to read the following information.

⚠ WARNING

Improper accessories or modifications can cause a crash in which you can be seriously hurt or killed.

Follow all instructions in this owner's manual regarding accessories and modifications.

Accessories

We strongly recommend that you use only Honda Genuine Accessories that have been specifically designed and tested for your motorcycle. Because Honda cannot test all other accessories, you must be personally responsible for proper selection, installation and use of non-Honda accessories. Check with your dealer for assistance and always follow these guidelines:

- Make sure the accessory does not obscure any lights, reduce ground clearance and banking angle, limit suspension travel or steering travel, alter your riding position or interfere with operating any controls.
- Be sure electrical equipment does not exceed the motorcycle's electrical system capacity (page 115). A blown fuse can cause a loss of lights or engine power.

- Do not pull a trailer or sidecar with your motorcycle. This motorcycle was not designed for these attachments, and their use can seriously impair your motorcycle's handling.

Modifications

We strongly advise you not to remove any original equipment or modify your motorcycle in any way that would change its design or operation. Such changes could seriously impair your motorcycle's handling, stability and braking, making it unsafe to ride.

Removing or modifying your lights, mufflers, emission control system or other equipment can also make your motorcycle illegal.

PARTS LOCATION

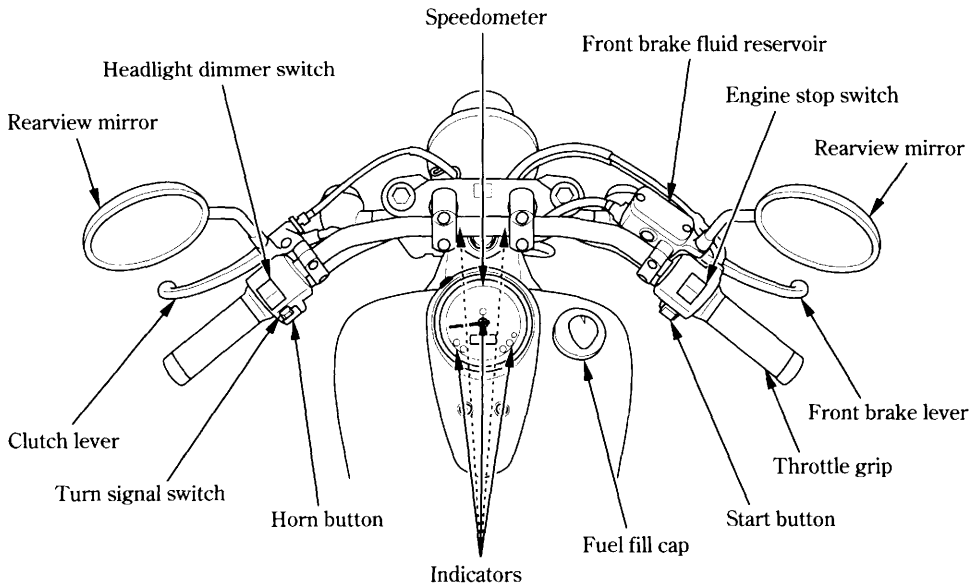

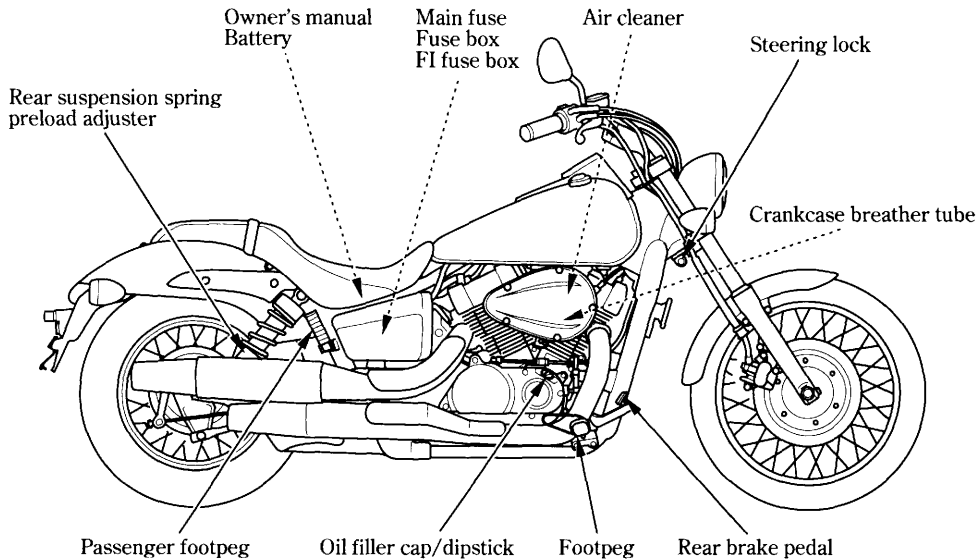

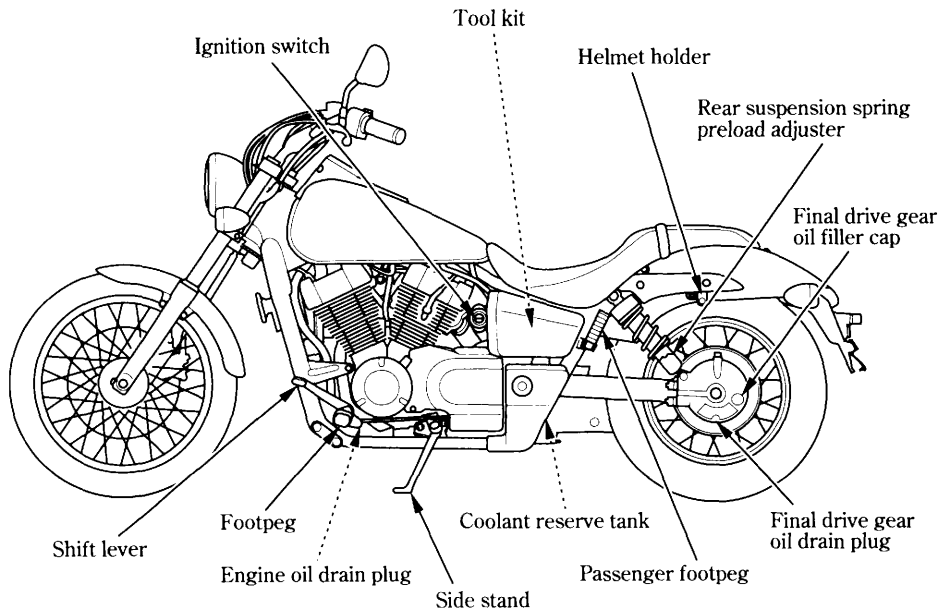

INSTRUMENTS AND INDICATORS

The indicators are located within and ahead of the speedometer.

Their functions are described in the table on the following pages.

- (1) Speedometer
- (2) High beam indicator
- (3) Turn signal indicator
- (4) Immobilizer system (HISS) indicator
- (5) PGM-FI multifunction indicator lamp (MIL)
- (6) High coolant temperature indicator
- (7) Odometer/Tripmeter display
- (8) Low oil pressure indicator
- (9) Neutral indicator
- (10) Odometer/Tripmeter select and reset button
- (11) Fuel indicator

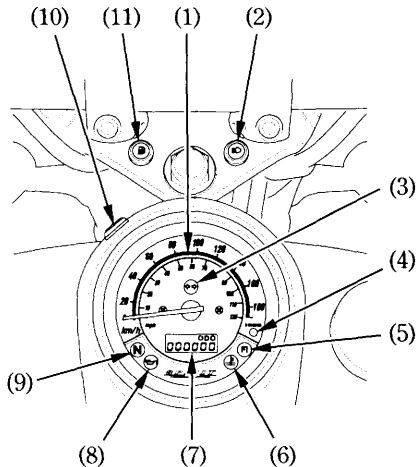

(Ref.No.) Description	Function
(1) Speedometer	Shows riding speed. This shows your speed in kilometers per hour (km/h) and/or miles per hour (mph) depending on the type.
(2) High beam indicator (blue)	Lights when the headlight is on high beam.
(3) Turn signal indicator (green)	Flashes when either turn signal operates.
(4) Immobilizer system (HISS) indicator (red)	This indicator lights for a few seconds when the ignition switch is turned ON and the engine stop switch is at \odot (RUN). It will then go off if the properly-coded key has been inserted. If an improperly-coded key has been inserted, the indicator will remain on and the engine will not start (page 39). When the blinking function of this indicator is valid and the ignition switch is OFF, it keeps blinking for 24 hours (page 40).

(Ref.No.) Description	Function
(5) PGM-FI malfunction indicator lamp (MIL) (red)	<p>Lights when there is any abnormality in the PGM-FI (Programmed Fuel Injection) system. Should also light for a few seconds and then go off when the ignition switch is turned ON and engine stop switch is at ○ (RUN).</p> <p>If it comes on at any other time, reduce speed and take the motorcycle to your Honda dealer as soon as possible.</p>
(6) High coolant temperature indicator (red)	<p>Lights when the coolant is over the specified temperature. If the indicator goes on while riding, stop the engine and check the reserve tank coolant level. Read pages 24 – 25 and do not ride the motorcycle until the problem has been corrected.</p> <p>NOTICE</p> <p>Exceeding maximum running temperature may cause serious engine damage.</p>

(Ref.No.) Description	Function
(7) Odometer/Tripmeter display <div style="border: 1px solid black; padding: 5px; margin-left: 20px;"> Odometer </div> <div style="border: 1px solid black; padding: 5px; margin-left: 20px;"> Tripmeter 1 and 2 </div>	Shows odometer and tripmeter. Shows the total miles (For E type) or kilometers (Except E type) ridden (page 16). Shows the number of miles (For E type) or kilometers (Except E type) ridden since you last reset the meter (page 16).
(8) Low oil pressure indicator (red)	Lights when the engine oil pressure is below normal operating range. Should light when ignition switch is ON and engine is not running. Should go out when the engine starts, except for occasional flickering at or near idling speed when engine is warm. <div style="border: 1px solid black; padding: 5px; width: fit-content; margin: 10px auto;"> NOTICE </div> Running the engine with insufficient oil pressure may cause serious engine damage.

(Ref.No.) Description	Function
(9) Neutral indicator (green)	Lights when the transmission is in neutral.
(10) Odometer/Tripmeter select and reset button	This button is used to reset the tripmeter or to select the tripmeter or odometer (page 16).
(11) Fuel indicator (orange)	<p>Lights when there is only few fuel left in the fuel tank. The amount of fuel left in the tank when lights and with the vehicle set upright is approximately:</p> <p>3.5 ℓ (0.92 US gal , 0.77 Imp gal)</p> <p>Should also light for a few seconds and then go off when the ignition switch is turned ON.</p>

Odometer/Tripmeter Display

The display (1) has two functions, odometer and tripmeter.

The tripmeter has two sub modes, "TRIP 1" and "TRIP 2".

Push the button (2) to select the "ODO", "TRIP 1" or "TRIP 2" mode.

To reset the tripmeter, push and hold the button with the display in the "TRIP 1" or "TRIP 2" mode.

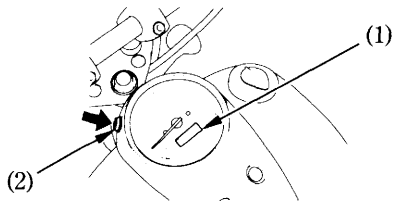

(1) Odometer/Tripmeter display

(2) Odometer/Tripmeter select and reset button

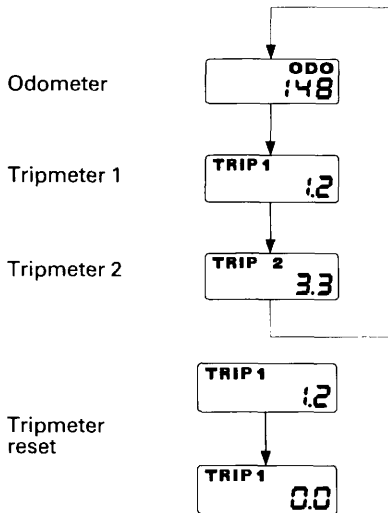

MAJOR COMPONENTS

(Information you need to operate this motorcycle)

SUSPENSION

Each shock absorber (1) has 5 adjustment positions for different load or riding conditions.

Use a pin spanner (2) and extension bar (3) to adjust the rear shocks.

Always adjust the shock absorber position in sequence (1-2-3-4-5 or 5-4-3-2-1).

Attempting to adjust directly from 1 to 5 or 5 to 1 may damage the shock absorber.

Position 1 is for light loads and smooth road conditions. Positions 3 to 5 increase spring preload for a stiffer rear suspension, and can be used when the motorcycle is heavily loaded. Be certain to adjust both shock absorbers to the same position.

Standard position: 2

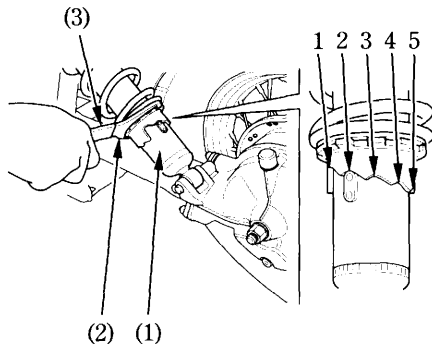

- (1) Shock absorber
- (2) Pin spanner
- (3) Extension bar

BRAKES

Front Brake

This motorcycle has a hydraulic front disc brake.

As the brake pads wear, brake fluid level drops.

There are no adjustments to perform, but fluid level and pad wear must be inspected periodically. The system must be inspected frequently to ensure there are no fluid leaks.

If the control lever free travel becomes excessive and the brake pads are not worn beyond the recommended limit (page 92), there is probably air in the brake system and it must be bled. See your Honda dealer for this service.

Front Brake Fluid Level:

With the motorcycle in an upright position, check the fluid level. It should be above the LOWER level mark (1). If the level is at or below the LOWER level mark, check the brake pads for wear (page 92).

Worn pads should be replaced. If the pads are not worn, have your brake system inspected for leaks.

The recommended brake fluid is Honda DOT 4 brake fluid from a sealed container, or an equivalent.

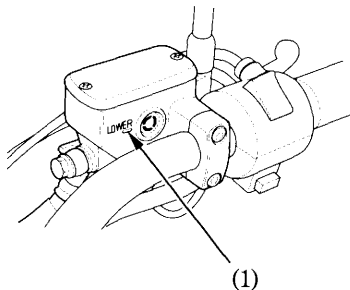

(1) LOWER level mark

Other Checks:

Make sure there are no fluid leaks. Check for deterioration or cracks in the hoses and fittings.

Rear Brake

Pedal Height Adjustment:

Place the motorcycle on its side stand.

The stopper bolt (1) is provided to allow adjustment of the pedal height. To adjust the pedal height, loosen the lock nut (2) and turn the stopper bolt. Tighten the lock nut.

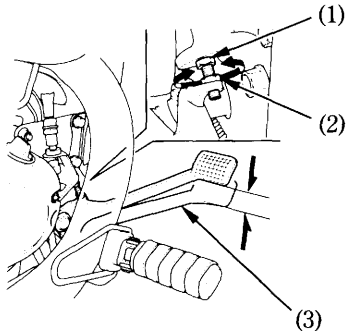

- (1) Stopper bolt
- (2) Lock nut
- (3) Rear brake pedal

Brake Adjustment:

1. Place the motorcycle on its side stand.
2. Measure the distance the rear brake pedal (3) moves before the brake starts to take hold.

Freeplay should be:

20 – 30 mm (0.8 – 1.2 in)

If adjustment is necessary, turn the rear brake adjusting nut (4).

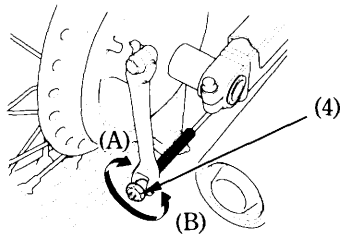

- (4) Rear brake adjusting nut
- (A) Decrease freeplay
- (B) Increase freeplay

3. Apply the brake several times and check for free wheel rotation after the brake lever is released.

Make sure the cut-out on the adjusting nut is seated on the brake arm pin (5) after making final freeplay adjustment.

If proper adjustment cannot be obtained by this method, see your Honda dealer.

Other Checks:

Make sure the brake rod, brake arm, spring and fasteners are in good condition.

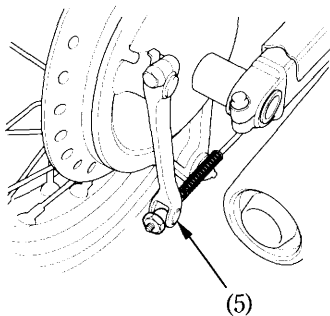

(5) Brake arm pin

CLUTCH

Clutch adjustment may be required if the motorcycle stalls when shifting into gear or tends to creep; or if the clutch slips, causing acceleration to lag behind engine speed. Minor adjustments can be made with the clutch cable adjuster (1) at the clutch lever (2).

Normal clutch lever freeplay is:

10–20 mm (0.4–0.8 in)

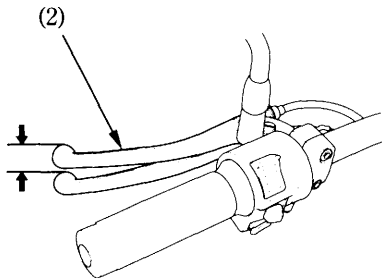

(2) Clutch lever

1. Loosen the lock nut (3) and turn the clutch cable adjuster. Tighten the lock nut and check the adjustment.
2. If the adjuster is threaded out near its limit or if the correct freeplay cannot be obtained, loosen the lock nut and turn in the clutch cable adjuster completely. Tighten the lock nut.

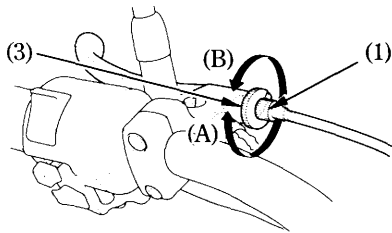

(1) Clutch cable adjuster

(3) Lock nut

(A) Increase freeplay

(B) Decrease freeplay

3. Loosen the lock nut (4) at the lower end of the cable. Turn the adjusting nut (5) to obtain the specified freeplay. Tighten the lock nut and check the adjustment.
4. Start the engine, pull in the clutch lever and shift into gear. Make sure the engine does not stall and the motorcycle does not creep. Gradually release the clutch lever and open the throttle. The motorcycle should begin to move smoothly and accelerate gradually.

If proper adjustment cannot be obtained or the clutch does not work correctly, see your Honda dealer.

Other Checks:

Check the clutch cable for kinks or signs of wear that could cause sticking or failure. Lubricate the clutch cable with a commercially available cable lubricant to prevent premature wear and corrosion.

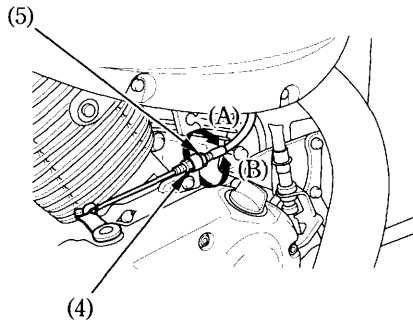

- (4) Lock nut
- (5) Adjusting nut

- (A) Increase freeplay
- (B) Decrease freeplay

COOLANT

Coolant Recommendation

The owner must properly maintain the coolant to prevent freezing, overheating, and corrosion. Use only high quality ethylene glycol antifreeze containing corrosion protection inhibitors specifically recommended for use in aluminum engines. (SEE ANTIFREEZE CONTAINER LABEL).

Use only low-mineral drinking water or distilled water as a part of the antifreeze solution. Water that is high in mineral content or salt may be harmful to the aluminum engine.

Using coolant with silicate inhibitors may cause premature wear of water pump seals or blockage of radiator passages.

Using tap water may cause engine damage.

The factory provides a 50/50 solution of antifreeze and distilled water in this motorcycle. This coolant solution is recommended for most operating temperatures and provides good corrosion protection. A higher concentration of antifreeze decreases the cooling system performance and is recommended only when additional protection against freezing is needed. A concentration of less than 40/60 (40% antifreeze) will not provide proper corrosion protection. During freezing temperatures, check the cooling system frequently and add higher concentrations of antifreeze (up to a maximum of 60% antifreeze) if required.

Inspection

The reserve tank is behind the frame.

Check the coolant level in the reserve tank (1) while the engine is at the normal operating temperature with the motorcycle in an upright position. If the coolant level is below the LOWER level mark (2), remove the reserve tank cap (3) and add coolant mixture until it reaches the UPPER level mark (4). Always add coolant to the reserve tank.

Do not attempt to add coolant by removing the radiator cap.

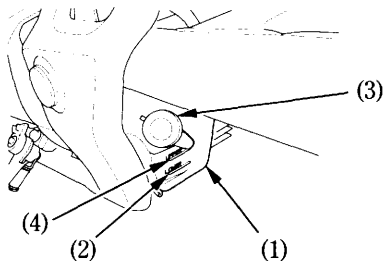

- (1) Reserve tank
- (2) LOWER level mark
- (3) Reserve tank cap
- (4) UPPER level mark

If the reserve tank is empty, or if coolant loss is excessive, check for leaks and see your Honda dealer for repair.

FUEL

Fuel Tank

The fuel tank capacity including the reserve supply is:

14.5 l (3.83 US gal , 3.19 Imp gal)

To open the fuel fill cap (1), insert the ignition key (2) and turn it clockwise. The fuel fill cap will pop up and can be lifted off.

Do not overfill the tank. There should be no fuel in the filler neck (3).

After refueling, to close the fuel fill cap, align the latch in the cap with the slot in the filler neck. Push the fuel fill cap into the filler neck until it snaps closed and locks. Remove the key.

WARNING

Petrol is highly flammable and explosive. You can be burned or seriously injured when handling fuel.

- Stop the engine and keep heat, sparks, and flame away.
- Refuel only outdoors.
- Wipe up spills immediately.

Use unleaded petrol with a research octane number of 91 or higher.

The use of leaded petrol will cause premature damage to the catalytic converters.

NOTICE

If “spark knock” or “pinking” occurs at a steady engine speed under normal load, change brands of petrol. If spark knock or pinking persists, consult your Honda dealer. Failure to do so is considered misuse, and damage caused by misuse is not covered by Honda’s Limited Warranty.

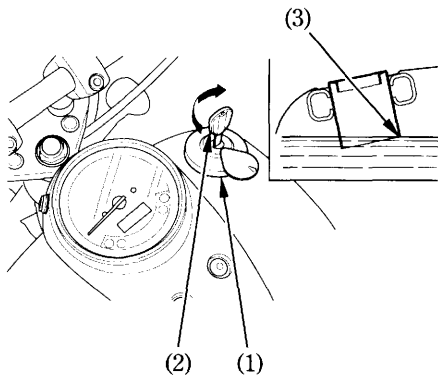

- (1) Fuel fill cap
- (2) Ignition key

- (3) Filler neck

Petrol Containing Alcohol

If you decide to use a petrol containing alcohol (gasohol), be sure it's octane rating is at least as high as that recommended by Honda. There are two types of "gasohol": one containing ethanol, and the other containing methanol. Do not use petrol that contains more than 10 % ethanol. Do not use petrol containing methanol (methyl or wood alcohol) that does not also contain cosolvents and corrosion inhibitors for methanol. Never use petrol containing more than 5 % methanol, even if it has cosolvents and corrosion inhibitors.

The use of petrol containing more than 10 % ethanol (or more than 5 % methanol) may:

- Damage the painting of the fuel tank.
- Damage the rubber tubes of the fuel line.
- Cause corrosion of the fuel tank.
- Cause poor drivability.

Before buying fuel from an unfamiliar station, try to find out if the fuel contains alcohol. If it does, confirm the type and percentage of alcohol used. If you notice any undesirable operating symptoms while using a petrol that contains alcohol, or one that you think contains alcohol, switch to a petrol that you know does not contain alcohol.

ENGINE OIL

Engine Oil Level Check

Check the engine oil level each day before riding the motorcycle.

The level must be maintained between the upper (1) and lower (2) level marks on the oil filler cap/dipstick (3).

1. Start the engine and let it idle for 3–5 minutes. Make sure the low oil pressure indicator goes off. If the indicator light remains on, stop the engine immediately.
2. Stop the engine and hold the motorcycle in an upright position on firm, level ground.
3. After 2–3 minutes, remove the oil filler cap/dipstick, wipe it clean, and reinsert the oil filler cap/dipstick without screwing it in. Remove the oil filler cap/dipstick. The oil level should be between the upper and lower level marks on the oil filler cap/dipstick.

4. If required, add the specified oil (see page 69) up to the upper level mark. Do not overfill.
5. Reinstall the oil filler cap/dipstick. Check for oil leaks.

NOTICE

Running the engine with insufficient oil pressure may cause serious engine damage.

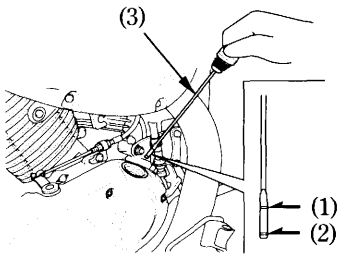

- (1) Upper level mark
- (2) Lower level mark
- (3) Oil filler cap/dipstick

FINAL DRIVE OIL

Oil Level Check

Check the final drive oil level when specified by the maintenance schedule (page 65).

1. Place the motorcycle on its side stand.
2. Remove the oil filler cap (1).
3. Check that the oil level reaches the lower edge of the oil cap hole (2).

If the level is low, check for leaks. Pour fresh oil through the oil filler inspection hole until it reaches the lower edge of the opening.

Recommended Oil:

HYPOID GEAR OIL SAE 80

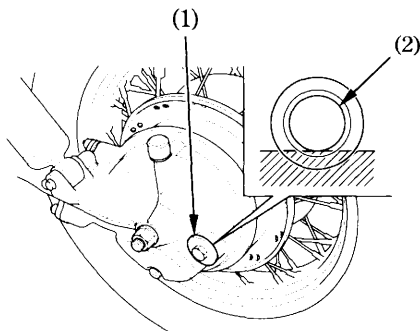

(1) Oil filler cap

(2) Oil cap hole

TYRES

To safely operate your motorcycle, the tyres must be the proper type and size, in good condition with adequate tread, and correctly inflated.

⚠ WARNING

Using tyres that are excessively worn or improperly inflated can cause a crash in which you can be seriously hurt or killed.

Follow all instructions in this owner's manual regarding tyre inflation and maintenance.

Air Pressure

Properly inflated tyres provide the best combination of handling, tread life, and riding comfort. Generally, underinflated tyres wear unevenly, adversely affect handling, and are more likely to fail from being overheated. Underinflated tyres can also cause wheel damage in rocky terrain. Overinflated tyres make your motorcycle ride harshly, are more prone to damage from surface hazards, and wear unevenly.

Make sure the valve stem caps are secure. If necessary, install new caps.

Always check air pressure when your tyres are “cold” – when the motorcycle has been parked for at least three hours. If you check air pressure when your tyres are “warm” – when the motorcycle has been ridden for even a few miles – the readings will be higher than if the tyres were “cold”. This is normal, so do not let air out of the tyres to match the recommended cold air pressures given below. If you do, the tyres will be underinflated.

The recommended “cold” tyre pressures are:

kPa (kgf/cm ² , psi)	
Driver only	Front 200 (2.00 , 29) Rear 200 (2.00 , 29)
Driver and one passenger	Front 200 (2.00 , 29) Rear 250 (2.50 , 36)

Inspection

Whenever you check the tyre pressures, you should also examine the tyre treads and sidewalls for wear, damage, and foreign objects:

Look for:

- Bumps or bulges in the side of the tyre or the tread. Replace the tyre if you find any bumps or bulges.
- Cuts, splits or cracks in the tyre. Replace the tyre if you can see fabric or cord.
- Excessive tread wear.

Also, if you hit a pothole or hard object, pull to the side of the road as soon as you can safely and carefully inspect the tyres for damage.

Tread Wear

Replace tyres before tread depth at the center of the tyre reaches the following limit:

Minimum tread depth	
Front:	1.5 mm (0.06 in)
Rear:	2.0 mm (0.08 in)

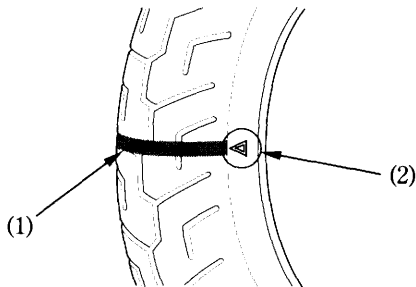

- (1) Wear indicator
- (2) Wear indicator location mark

Tube Repair and Replacement

If a tube is punctured or damaged, you should replace it as soon as possible. A tube that is repaired may not have the same reliability as a new one, and it may fail while you are riding.

If you need to make a temporary repair by patching a tube or using an aerosol sealant, ride cautiously at reduced speed and have the tube replaced before you ride again. Any time a tube is replaced, the tyre should be carefully inspected as described on page 32 .

Tyre Replacement

The tyres that came on your motorcycle were designed to match the performance capabilities of your motorcycle and provide the best combination of handling, braking, durability and comfort.

WARNING

Installing improper tyres on your motorcycle can affect handling and stability. This can cause a crash in which you can be seriously hurt or killed.

Always use the size and type of tyres recommended in this owner's manual.

The recommended tyres for your motorcycle are:

Front: 90/90 – 21M/C 54S

DUNLOP

D404F

BRIDGESTONE

EXEDRA G701

Rear: 160/80 – 15M/C 74S

DUNLOP

D404

BRIDGESTONE

EXEDRA G702

Type: bias-ply, tube

Whenever you replace a tyre, use one that is equivalent to the original and be sure the wheel is balanced after the new tyre is installed.

Also remember to replace the inner tube whenever you replace a tyre. The old tube will probably be stretched, and if installed in a new tyre, it could fail.

ESSENTIAL INDIVIDUAL COMPONENTS

IGNITION SWITCH

The ignition switch (1) is in front of the left side cover.

The headlight, taillight and license light will come on whenever you turn the ignition switch ON. If your motorcycle is stopped with the ignition switch ON and the engine is not running, the headlight, taillight and license light will still be on, resulting in battery discharge.

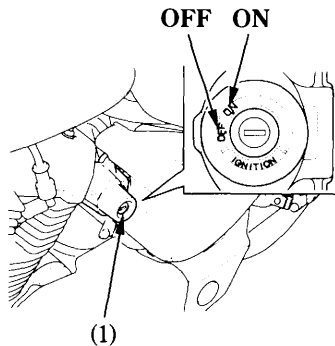

(1) Ignition switch

Key Position	Function	Key Removal
OFF	Engine and lights cannot be operated.	Key can be removed
ON	Engine and light can be operated.	Key cannot be removed

KEYS

This motorcycle has two keys (1) and a key number plate (2).

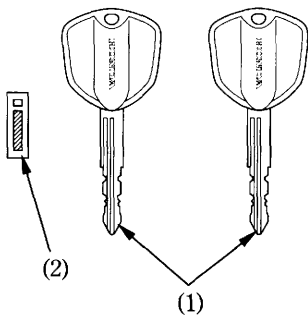

(1) Keys

(2) Key number plate

You will need the key number if you ever have to replace a key. Store the plate in a safe place.

To reproduce keys, bring all keys, key number plate and motorcycle to your Honda dealer.

Up to four keys can be registered with the immobilizer system (HISS), including the ones in hand.

If all keys are lost, the PGM-FI unit/ignition control module must be replaced. To avoid this possibility we recommend that if only one key is left, you immediately have it reproduced to ensure that a back-up is available.

These keys contain electronic circuits that are activated by the immobilizer system (HISS). They will not work to start the engine if the circuits are damaged.

- Do not drop the keys or set heavy objects on them.
- Do not grind, drill or in any way alter the original shape of the keys.
- Keep the keys away from magnetic objects.

IMMOBILIZER SYSTEM (HISS)

HISS is the abbreviation of Honda Ignition Security System.

The immobilizer system (HISS) protects your motorcycle from theft. A properly-coded key must be used in the ignition switch for the engine to start. If an improperly-coded key (or other device) is used the engine's starting circuit is disabled.

When the ignition switch is turned ON and the engine stop switch is at “  ” (RUN), the immobilizer system (HISS) indicator lights for a few seconds, then goes off. If the indicator remains on, it means the system does not recognize the coding of the key. Turn the ignition switch to OFF, remove the key, reinsert and turn the switch ON again.

The immobilizer system has such a function that keeps the immobilizer system (HISS) indicator blinking at 2 second intervals for 24 hours. This blinking function can be turned on or off.

To alter the blinking function:

1. Turn the ignition switch ON.
2. While pressing the button (1), simultaneously turn the ignition switch OFF when the display function mode is odometer.

The immobilizer system (HISS) indicator (2) instantly flash, the function is enabled.

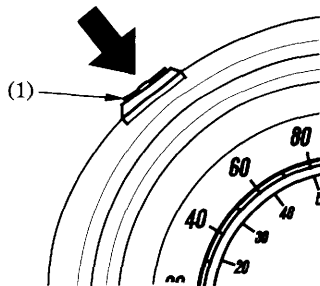

(1) Odometer/Tripmeter select and reset button

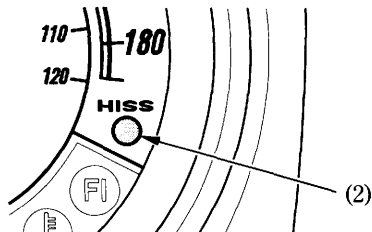

(2) Immobilizer system (HISS) indicator

If the system repeatedly does not recognize the coding of your key, contact your Honda dealer.

- The system may not recognize the key's coding if any other immobilizer key is near the ignition switch. To make sure the system recognizes the key code, keep each immobilizer key on a separate ring.
- Do not attempt to alter the immobilizer system (HISS) or add other devices to it. Electrical problems could result, making it impossible to start your motorcycle.
- If all keys are lost, the PGM-FI unit/ignition control module must be replaced.

EC Directives



This immobilizer system complies with the R & TTE (Radio equipment and telecommunications terminal equipment and the mutual recognition of their conformity) Directive.



The declaration of conformity to R & TTE Directive is provided to the owner at the time of purchase. The declaration of conformity should be kept at a safe place. When the declaration of conformity is lost or is not provided, contact your Honda dealer.

RIGHT HANDLEBAR CONTROLS

Engine Stop Switch

The engine stop switch (1) is next to the throttle grip. When the switch is in the  (RUN) position, the engine will operate. When the switch is in the  (OFF) position, the engine will not operate. This switch is intended primarily as a safety or emergency switch and should normally remain in the  (RUN) position.

If your motorcycle is stopped with the ignition switch ON and the engine stop switch  (OFF), the headlight, taillight and license light will still be on, resulting in battery discharge.

Start Button

The start button (2) is below the engine stop switch.

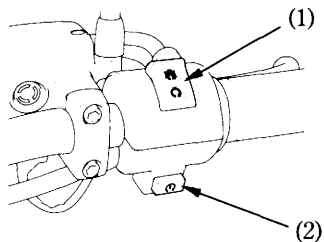

When the start button is pressed, the starter motor cranks the engine, the headlight will automatically go out, but the taillight will stay on. If the engine stop switch is in the  (OFF) position, the starter motor will not operate. See page 53 for the starting procedure.





- (1) Engine stop switch
- (2) Start button

LEFT HANDLEBAR CONTROLS

Headlight Dimmer Switch (1)

Push the headlight dimmer switch to  to select high beam or to  to select low beam.

Turn Signal Switch (2)

Move to  to signal a left turn,  to signal a right turn. Press to turn signal off.

Horn Button (3)

Press the button to sound the horn.

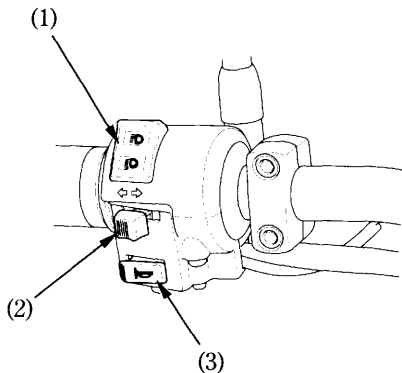

(1) Headlight dimmer switch

(2) Turn signal switch

(3) Horn button

FEATURES

(Not required for operation)

STEERING LOCK

The steering lock (1) is on the steering column.

To lock the steering, turn the handlebar all the way to left, insert the ignition key (2) into the lock, turn the key 180° clockwise while pushing in and remove it.

To unlock the steering, perform the locking sequence in the reverse order.

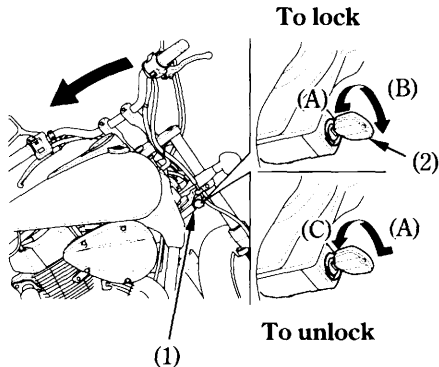

- (1) Steering lock
(2) Ignition key

- (A) Push in
(B) Turn clockwise
(C) Turn counterclockwise

HELMET HOLDER

The helmet holder (1) is on the left side below the seat. The helmet holder is designed to secure your helmet while parked.

Insert the ignition key (2) and turn it counterclockwise to unlock.

Hang your helmet on the holder pin (3) and push it in to lock. Remove the key.

⚠ WARNING

Riding with a helmet attached to the holder can interfere with the rear wheel or suspension and could cause a crash in which you can be seriously hurt or killed.

Use the helmet holder only while parked. Do not ride with a helmet secured by the holder.

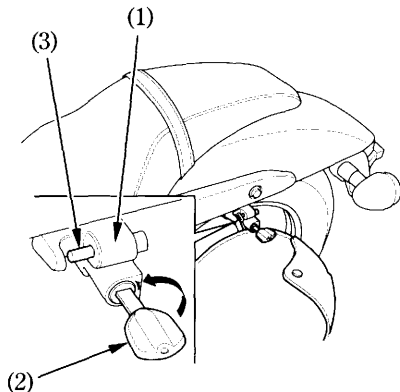

- (1) Helmet holder
- (2) Ignition key
- (3) Holder pin

DOCUMENT BAG

The document bag (1) is located under the seat.

To access the document bag, remove the seat (page 48).

This owner's manual and other documents should be stored in the document bag. When washing your motorcycle, be careful not to flood this area with water.

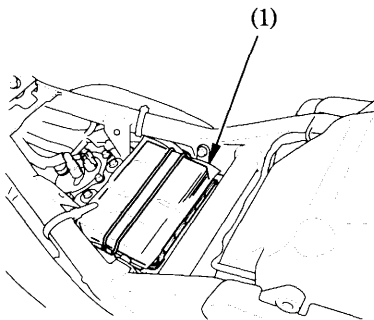

(1) Document bag

SIDE COVER

The right side cover must be removed to inspect fuse. The left side cover must be removed to access the tool kit and colour label.

The right and left side covers can be removed in the same manner.

Removal:

1. Carefully pull the side cover (1) (2) out until the prongs (3) are clear of the rubber grommets (4).
2. Remove the side cover.

Installation:

1. Align the prongs with the rubber grommets.
2. Push the prongs in.

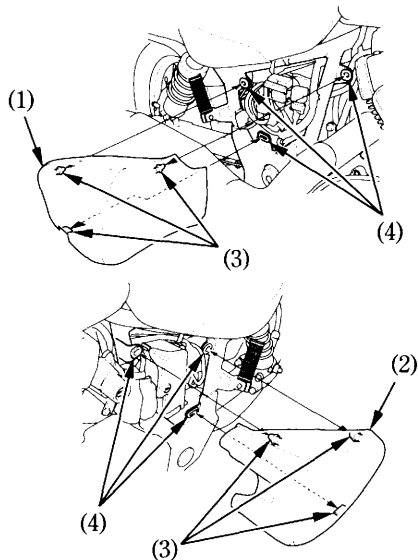

(1) Right side cover

(2) Left side cover

(3) Prongs

(4) Rubber grommets

SEAT

The seat must be removed for battery maintenance and to access the owner's manual.

Removal:

1. Remove the bolt A (1) and bolts B (2).
2. Pull the seat (3) back and up.

Installation:

1. Insert the seat tab (4) into the recess (5) under the frame.
2. Tighten the bolt A and bolts B securely.

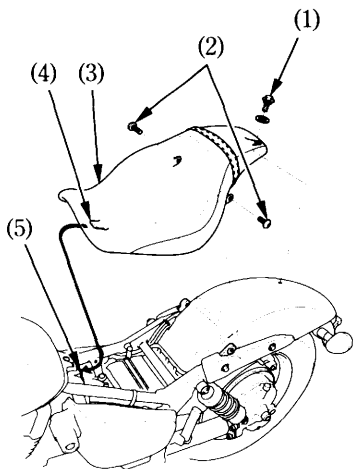

- (1) Bolt A
(2) Bolts B
(3) Seat

- (4) Seat tab
(5) Recess

HEADLIGHT AIM VERTICAL ADJUSTMENT

Vertical adjustment can be made by turning the screw (1) in or out as necessary. Obey local laws and regulations.

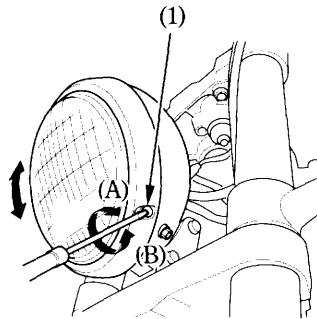
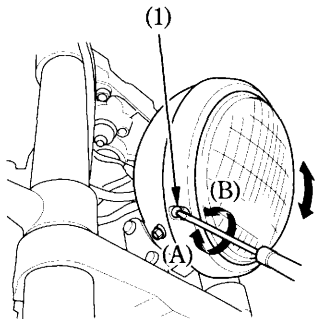

(1) Screw

(A) Up

(B) Down

OPERATION

PRE-RIDE INSPECTION

For your safety, it is very important to take a few moments before each ride to walk around your motorcycle and check its condition. If you detect any problem, be sure you take care of it, or have it corrected by your Honda dealer.

WARNING

Improperly maintaining this motorcycle or failing to correct a problem before riding can cause a crash in which you can be seriously hurt or killed.

Always perform a pre-ride inspection before every ride and correct any problems.

1. Engine oil level—add engine oil if required (page 29). Check for leaks.
2. Fuel level—fill fuel tank when necessary (page 26). Check for leaks.
3. Coolant level—add coolant if required. Check for leaks (pages 24 – 25).
4. Brakes – check operation;
front: make sure there is no brake fluid leakage (page 19).
rear: adjust freeplay if necessary (pages 20 – 21).
5. Tyres—check condition and pressure (pages 31 – 35).
6. Throttle—check for smooth opening and full closing in all steering positions.
7. Lights and horn—check that headlight, brake/tail light, position light (except U type), license light, turn signals, indicators and horn function properly.
8. Engine stop switch—check for proper function (page 42).
9. Side stand ignition cut-off system—check for proper function (page 82).

STARTING THE ENGINE

Always follow the proper starting procedure described below.

This motorcycle is equipped with a side stand ignition cut-off system. The engine cannot be started if the side stand is down, unless the transmission is in neutral. If the side stand is up, the engine can be started in neutral or in gear with the clutch lever pulled in. After starting with the side stand down, the engine will shut off if the transmission is put in gear before raising the side stand.

To protect the catalytic converters in your motorcycle's exhaust system, avoid extending idling and the use of leaded petrol.

Your motorcycle's exhaust contains poisonous carbon monoxide gas. High levels of carbon monoxide can collect rapidly in enclosed areas such as a garage. Do not run the engine with the garage door closed. Even with the door open, run the engine only long enough to move your motorcycle out of the garage.

Do not use the electric starter for more than 5 seconds at a time. Release the start button for approximately 10 seconds before pressing it again.

Preparation

Before starting, insert the key, turn the ignition switch ON and confirm the following:

- The transmission is in neutral (neutral indicator is ON).
- The engine stop switch is at \odot (RUN).
- The low oil pressure indicator is ON.
- The immobilizer system (HISS) indicator is OFF.
- The PGM-FI malfunction indicator lamp (MIL) is OFF.

The low oil pressure indicator should go off a few seconds after the engine starts. If the low oil pressure indicator lights during operation, stop the engine immediately and check the engine oil level.

NOTICE

Operating the engine with insufficient oil pressure can cause serious engine damage.

Starting Procedure

This motorcycle has a fuel-injected with an automatic choke. Follow the procedure indicated below.

Any Air Temperature

1. With the throttle completely closed, press the start button.

The engine will not start if the throttle is fully open (because the electronic control module cuts off the fuel supply).

Flooded Engine

If the engine fails to start after repeated attempts, it may be flooded.

1. Leave the engine stop switch set to  (RUN).
2. Open throttle fully.
3. Press the start button for 5 seconds.
4. Follow the normal starting procedure.

If the engine starts with unstable idle, open the throttle slightly.

If the engine does not start, wait for 10 seconds, then follow steps 1 – 4 again.

Ignition Cut Off

Your motorcycle is designed to automatically stop the engine and fuel pump if the motorcycle is over-turned (a banking sensor cuts off the ignition system). Before restarting the engine, you must turn the ignition switch to the OFF position and then back to ON.

RUNNING-IN

Help assure your motorcycle's future reliability and performance by paying extra attention to how you ride during the first 500 km (300 miles).

During this period, avoid full-throttle starts and rapid acceleration.

RIDING

Review Motorcycle Safety (pages 1 – 7) before you ride.

Make sure you understand the function of the side stand mechanism. (See MAINTENANCE SCHEDULE on page 65 and explanation for SIDE STAND on page 82).

Make sure flammable materials such as dry grass or leaves do not come in contact with the exhaust system when riding, idling, or parking your motorcycle.

1. After the engine has been warmed up, the motorcycle is ready for riding.
2. While the engine is idling, pull in the clutch lever and depress the shift lever to shift into 1st (low) gear.

3. Slowly release the clutch lever and at the same time gradually increase engine speed by opening the throttle. Coordination of the throttle and clutch lever will assure a smooth positive start.
4. When the motorcycle attains a moderate speed, close the throttle, pull in the clutch lever and shift to 2nd gear by raising the shift lever.

This sequence is repeated to progressively shift to 3rd, 4th and 5th (top) gears.

5. Coordinate the throttle and brakes for smooth deceleration.
6. Both front and rear brakes should be used at the same time and should not be applied strongly enough to lock the wheel, or braking effectiveness will be reduced and control of the motorcycle be difficult.

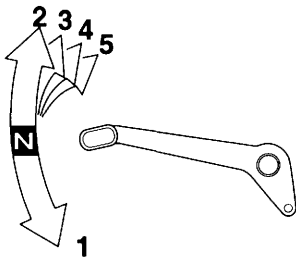

BRAKING

For normal braking, apply both the brake pedal and lever while down-shifting to match your road speed. For maximum braking, close the throttle and firmly apply the pedal and lever; pull in the clutch lever before coming to a complete stop to prevent stalling the engine.

Important Safety Reminders:

- Independent operation of only the brake lever or brake pedal reduces stopping performance.
- Extreme application of the brake controls may cause wheel lock, reducing control of the motorcycle.
- When possible, reduce speed or brake before entering a turn; closing the throttle or braking in mid-turn may cause wheel slip. Wheel slip will reduce control of the motorcycle.

- When riding in wet or rainy conditions, or on loose surfaces, the ability to maneuver and stop will be reduced. All of your actions should be smooth under these conditions. Rapid acceleration, braking or turning may cause loss of control. For your safety, exercise extreme caution when braking, accelerating or turning.
- When descending a long, steep grade, use engine compression braking by down-shifting, with intermittent use of both brakes.
Continuous brake application can overheat the brakes and reduce their effectiveness.
- Riding with your foot resting on the brake pedal or your hand on the brake lever may actuate the brakelight, giving a false indication to other drivers. It may also overheat the brakes, reducing effectiveness.

PARKING

1. After stopping the motorcycle, shift the transmission into neutral, turn the handlebar fully to the left, turn the ignition switch OFF and remove the key.
2. Use the side stand to support the motorcycle while parked.

Park the motorcycle on firm, level ground to prevent it from falling over.

If you must park on a slight incline, aim the front of the motorcycle uphill to reduce the possibility of rolling off the side stand or overturning.

3. Lock the steering to help prevent theft (page 44).

Make sure flammable materials such as dry grass or leaves do not come in contact with the exhaust system when parking your motorcycle.

ANTI-THEFT TIPS

1. Always lock the steering and never leave the key in the steering lock. This sounds simple but people do forget.
2. Be sure the registration information for your motorcycle is accurate and current.
3. Park your motorcycle in a locked garage whenever possible.
4. Use an additional anti-theft device of good quality.
5. Put your name, address, and phone number in this Owner's Manual and keep it on your motorcycle at all times. Many times stolen motorcycles are identified by information in the Owner's Manuals that are still with them.

NAME: _____

ADDRESS: _____

PHONE NO: _____

MAINTENANCE

THE IMPORTANCE OF MAINTENANCE

A well-maintained motorcycle is essential for safe, economical and trouble-free riding. It will also help reduce air pollution.

To help you properly care for your motorcycle, the following pages include a Maintenance Schedule and a Maintenance Record for regularly scheduled maintenance.

These instructions are based on the assumption that the motorcycle will be used exclusively for its designed purpose. Sustained high speed operation or operation in unusually wet or dusty conditions will require more frequent service than specified in the Maintenance Schedule. Consult your Honda dealer for recommendations applicable to your individual needs and use.

If your motorcycle overturns or becomes involved in a crash, be sure your Honda dealer inspects all major parts, even if you are able to make some repairs.

WARNING

Improperly maintaining this motorcycle or failing to correct a problem before you ride can cause a crash in which you can be seriously hurt or killed.

Always follow the inspection and maintenance recommendations and schedules in this owner's manual.

MAINTENANCE SAFETY

This section includes instructions on some important maintenance tasks. You can perform some of these tasks with the tools provided – if you have basic mechanical skills.

Other tasks that are more difficult and require special tools are best performed by professionals. Wheel removal should normally be handled only by a Honda technician or other qualified mechanic; instructions are included in this manual only to assist in emergency service.

Some of the most important safety precautions follow. However, we cannot warn you of every conceivable hazard that can arise in performing maintenance. Only you can decide whether or not you should perform a given task.

WARNING

Failure to properly follow maintenance instructions and precautions can cause you to be seriously hurt or killed.

Always follow the procedures and precautions in this owner's manual.

SAFETY PRECAUTIONS

- Make sure the engine is off before you begin any maintenance or repairs. This will help eliminate several potential hazards:
 - * **Carbon monoxide poisoning from engine exhaust.**
Be sure there is adequate ventilation whenever you operate the engine.
 - * **Burns from hot parts.**
Let the engine and exhaust system cool before touching.
 - * **Injury from moving parts.**
Do not run the engine unless instructed to do so.
- Read the instructions before you begin, and make sure you have the tools and skills required.
- To help prevent the motorcycle from falling over, park it on a firm, level surface, using the side stand or a maintenance stand to provide support.

- To reduce the possibility of a fire or explosion, be careful when working around petrol or batteries. Use only nonflammable solvent, not petrol, to clean parts. Keep cigarettes, sparks and flames away from the battery and all fuel-related parts.

Remember that your Honda dealer knows your motorcycle best and is fully equipped to maintain and repair it.

To ensure the best quality and reliability, use only new Honda Genuine Parts or their equivalents for repair and replacement.

MAINTENANCE SCHEDULE

Perform the Pre-ride Inspection (page 50) at each scheduled maintenance period.

I: INSPECT AND CLEAN, ADJUST, LUBRICATE OR REPLACE IF NECESSARY

C: CLEAN R: REPLACE A: ADJUST L: LUBRICATE

The following items require some mechanical knowledge. Certain items (particularly those marked * and **) may require more technical information and tools. Consult your Honda dealer.

- * Should be serviced by your Honda dealer, unless the owner has proper tools and service data and is mechanically qualified. Refer to the Official Honda Shop Manual.
- ** In the interest of safety, we recommend these items be serviced only by your Honda dealer.

Honda recommends that your Honda dealer should road test your motorcycle after each periodic maintenance is carried out.

- NOTES:
- (1) At higher odometer readings, repeat at the frequency interval established here.
 - (2) Service more frequently when riding in unusually wet or dusty areas.
 - (3) Service more frequently when riding in rain or at full throttle.
 - (4) Replace every 2 years, or at indicated odometer interval, whichever comes first. Replacement requires mechanical skill.

ITEM	FREQUENCY	WHICHEVER → COMES FIRST ↓ NOTE	ODOMETER READING [NOTE (1)]								Refer to page
			× 1,000 km	1	6	12	18	24	30	36	
			× 1,000 mi	0.6	4	8	12	16	20	24	
* FUEL LINE					I		I		I	—	
* THROTTLE OPERATION					I		I		I	78	
AIR CLEANER	NOTE (2)					R			R	80	
CRANKCASE BREATHER	NOTE (3)			C	C	C	C	C	C	74	
SPARK PLUGS				I	R	I	R	I	R	75	
* VALVE CLEARANCE			I		I		I		I	—	
ENGINE OIL			R		R		R		R	69	
ENGINE OIL FILTER			R		R		R		R	71	
RADIATOR COOLANT	NOTE (4)				I		I		R	24	
* COOLING SYSTEM					I		I		I	—	
* SECONDARY AIR SUPPLY SYSTEM					I		I		I	—	

ITEM	FREQUENCY	WHICHEVER → COMES FIRST ↓ NOTE	ODOMETER READING [NOTE (1)]								Refer to page	
			× 1,000 km	1	6	12	18	24	30	36		
			× 1,000 mi	0.6	4	8	12	16	20	24		
		NOTE	MONTH									
						I		I			R	30, 77
		NOTE (4)				I	I	R	I	I	R	19
						I	I	I	I	I	I	92, 93
					I			I			I	18, 92, 93
*								I			I	100
*								I			I	49
					I	I	I	I	I	I	I	22
								I			I	82
*								I			I	81
*					I			I			I	—
**					I	I	I	I	I	I	I	—
**					I		I		I		I	—

TOOL KIT

The tool kit (1) is in the compartment box (2) behind the left side cover.

Remove the left side cover (page 47).

Open the compartment box cover (3), insert the ignition key (4) into the lock and turn it counterclockwise to unlock the compartment.

Some roadside repairs, minor adjustments and parts replacement can be performed with the tools contained in the kit.

- 10 × 14 mm Open end wrench
- 12 × 17 mm Open end wrench
- Pliers
- 4 mm Hex wrench
- 5 mm Hex wrench
- 6 mm Hex wrench
- No. 2 Phillips screwdriver
- No. 2 screwdriver
- Screwdriver handle
- Spark plug wrench
- Pin spanner
- Tool bag
- Extension bar

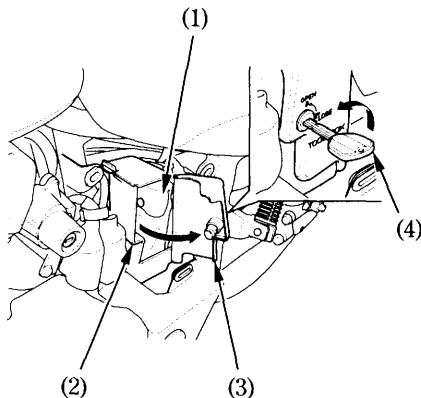

- (1) Tool kit
- (2) Compartment box
- (3) Compartment box cover
- (4) Ignition key

SERIAL NUMBERS

The frame and engine serial numbers are required when registering your motorcycle. They may also be required by your dealer when ordering replacement parts. Record the numbers here for your reference.

FRAME NO. _____

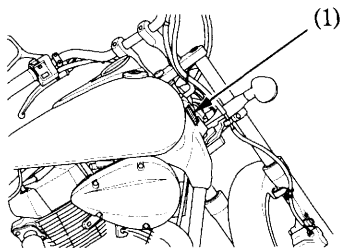

(1) Frame number

The frame number (1) is stamped on the right side of the steering head.

The engine number (2) is stamped on the right side of the cylinder.

ENGINE NO. _____

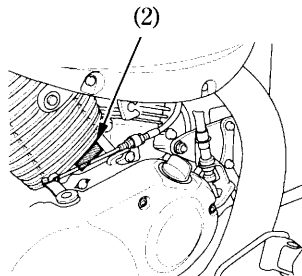

(2) Engine number

COLOUR LABEL

The colour label (1) is attached to the frame behind the left side cover (page 47). It is helpful when ordering replacement parts. Record the colour and code here for your reference.

COLOUR _____

CODE _____

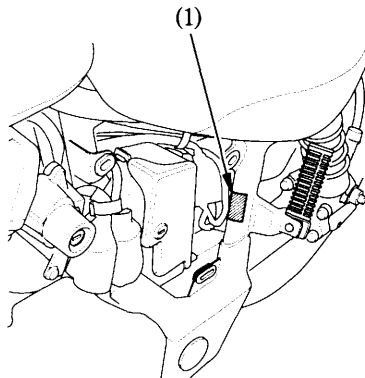

(1) Colour label

ENGINE OIL

Refer to the Safety Precautions on page 62 .

Oil Recommendation

API classification	SG or higher except oils labeled as energy conserving on the circular API service label
Viscosity	SAE 10W-30
JASO T 903 standard	MA

Suggested Oil
Honda "4-STROKE MOTORCYCLE OIL" or equivalent.

Your motorcycle does not need oil additives. Use the recommended oil.

Do not use oils with graphite or molybdenum additives. They may adversely affect clutch operation.

Do not use API SH or higher oils displaying a circular API "energy conserving" service label on the container. They may affect lubrication and clutch performance.

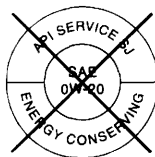

NOT RECOMMENDED

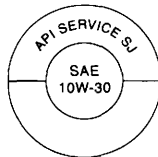

OK

Do not use non-detergent, vegetable, or castor based racing oils.

Viscosity:

Viscosity grade of engine oil should be based on average atmospheric temperature in your riding area. The following provides a guide to the selection of the proper grade or viscosity of oil to be used at various atmospheric temperatures.

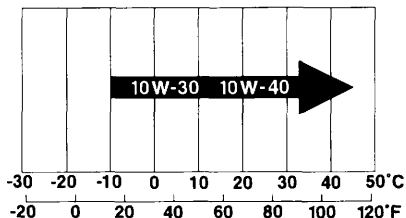

JASO T 903 standard

The JASO T 903 standard is an index for engine oils for 4-stroke motorcycle engines. There are two classes: MA and MB. Oil conforming to the standard is labeled on the oil container. For example, the following label shows the MA classification.

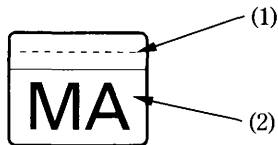

PRODUCT MEETING JASO T 903
COMPANY GUARANTEEING THIS MA PERFORMANCE:

- (1) Code number of the sales company of the oil
- (2) Oil classification

Engine Oil and Filter

Engine oil quality is the chief factor affecting engine service life. Change the engine oil as specified in the maintenance schedule (page 64).

When running in very dusty conditions, oil changes should be performed more frequently than specified in the maintenance schedule.

Please dispose of used engine oil in a manner that is compatible with the environment. We suggest you take it in a sealed container to your local recycling center or service station for reclamation. Do not throw it in the trash or pour it on the ground or down a drain.

Used engine oil may cause skin cancer if repeatedly left in contact with the skin for prolonged periods. Although this is unlikely unless you handle used oil on a daily basis, it is still advisable to thoroughly wash your hands with soap and water as soon as possible after handling used oil.

Changing the oil filter requires a special oil filter tool and a torque wrench. If you do not have these tools and the necessary skill, we recommend that you have your Honda dealer perform this service.

If a torque wrench is not used for this installation, see your Honda dealer as soon as possible to verify proper assembly.

Change the engine oil with the engine at normal operating temperature and the motorcycle on its side stand to assure complete and rapid draining.

1. To drain the oil, remove the oil filler cap/dipstick and oil drain plug (1) and sealing washer (2).

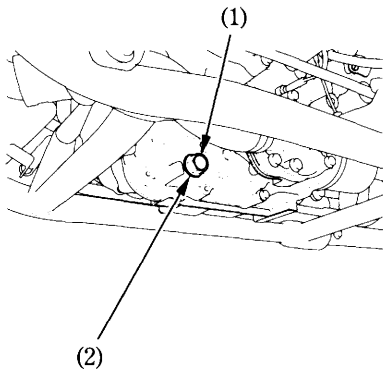

- (1) Oil drain plug
- (2) Sealing washer

2. Remove the oil filter (3) with a filter wrench and let the remaining oil drain out. Discard the oil filter.

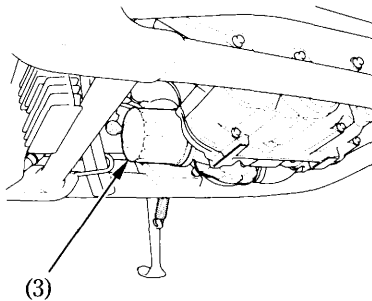

- (3) Oil filter

3. Apply a thin coat of engine oil to the new oil filter rubber seal (4).
4. Using a special tool and a torque wrench, install the new oil filter and tighten to a torque of:
26 N·m (2.7 kgf·m , 19 lbf·ft)

Use only the Honda genuine oil filter or a filter of equivalent quality specified for your model. Using the wrong Honda filter or a non-Honda filter which is not of equivalent quality may cause engine damage.

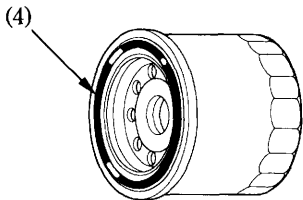

(4) Oil filter rubber seal

5. Check that the sealing washer on the drain plug is in good condition and install the plug. Replace the sealing washer every other time the oil is changed, or each time if necessary.
Engine oil drain plug torque:
29 N·m (3.0 kgf·m , 21 lbf·ft)
6. Fill the crankcase with the recommended grade oil; approximately:
2.6 l (2.7 US qt , 2.3 Imp qt)
7. Install the oil filler cap/dipstick.
8. Start the engine and let it idle for 3–5 minutes.
9. 2–3 minutes after stopping the engine, check that the oil level is at the upper level mark on the oil filler cap/dipstick with the motorcycle upright on firm, level ground. Make sure there are no oil leaks.

CRANKCASE BREATHER

Refer to the Safety Precautions on page 62 .

1. Remove the drain tube (1) and drain deposits into a suitable container.
2. Reinstall the drain tube.

Service more frequently when riding in rain or at full throttle.

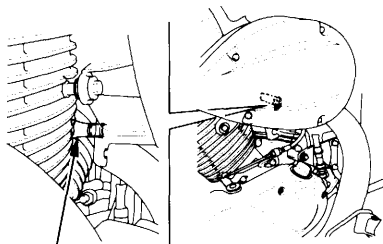

(1)

(1) Drain tube

SPARK PLUGS

Refer to the Safety Precautions on page 62 .

Recommended plugs:

Standard:

DPR7EA-9 (NGK) or
X22EPR-U9 (DENSO)

For extended high speed riding:

DPR8EA-9 (NGK) or
X24EPR-U9 (DENSO)

NOTICE

Never use a spark plug with an improper heat range. Severe engine damage could result.

1. Disconnect the spark plug caps (1) from the spark plugs.
2. Clean any dirt from around the spark plug bases.
Remove the spark plugs using a spark plug wrench (2) furnished in the tool kit.

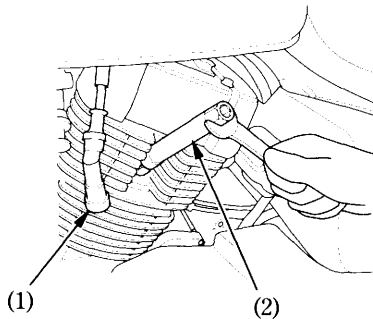

- (1) Spark plug cap
- (2) Spark plug wrench

3. Inspect the electrodes and center porcelain for deposits, erosion or carbon fouling. If the erosion or deposit is heavy, replace the plug. Clean a carbon or wet-fouled plug with a plug cleaner, otherwise use a wire brush.
4. Check the spark plug gap (3) using a wire-type feeler gauge. If adjustment is necessary, bend the side electrode (4) carefully.

The gap should be:

0.8–0.9 mm (0.03–0.04 in)

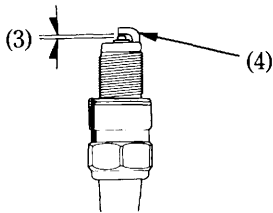

- (3) Spark plug gap
(4) Side electrode

5. Make sure the plug washer is in good condition.
6. With the plug washer attached, thread the spark plug in by hand to prevent cross-threading.
7. Tighten each spark plug:
 - If the old plug is good:
 - 1/8 turn after it seats.
 - If installing a new plug, tighten it twice to prevent loosening:
 - a) First, tighten the plug:
 - NGK: 3/4 turn after it seats.
 - DENSO: 1/2 turn after it seats.
 - b) Then loosen the plug.
 - c) Next, tighten the plug again:
 - 1/8 turn after it seats.

NOTICE

Improperly tightened spark plugs can damage the engine. If a plug is too loose, a piston may be damaged. If a plug is too tight, the threads may be damaged.

8. Reinstall the spark plug caps. Take care to avoid pinching any cables or wires.

FINAL DRIVE OIL

Refer to the Safety Precautions on page 62 .

Change the oil as specified in the maintenance schedule.

Change the oil with the final drive at normal operating temperature and the motorcycle upright on level ground to assure complete and rapid draining.

1. To drain the oil, remove the oil filler cap (1) and oil drain plug (2).
2. After the oil has completely drained, check that the sealing washer (3) on the drain plug is in good condition and install the drain plug.

Drain plug torque:

12 N·m (1.2 kgf·m , 9 lbf·ft)

3. Place the motorcycle on its side stand, fill the final drive with the recommended grade oil; approximately:

160 cm³ (5.4 US oz , 5.6 Imp oz)

Make sure the final drive is filled up to the lower edge of the oil filler inspection hole (4) with the recommended oil.

4. Install the oil filler cap.

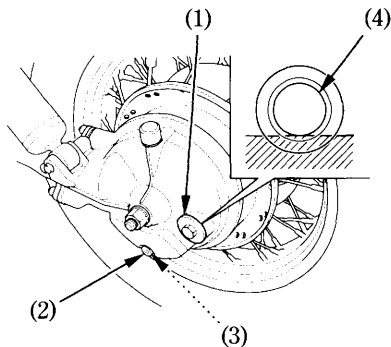

(1) Oil filler cap

(3) Sealing washer

(2) Oil drain plug

(4) Oil filler inspection hole

THROTTLE OPERATION

Refer to the Safety Precautions on page 62 .

1. Check for smooth rotation of the throttle grip from the fully open to the fully closed position at both full steering positions.
2. Measure the throttle grip freeplay at the throttle grip flange.
The standard freeplay should be approximately:
2 – 6 mm (0.1 – 0.2 in)

To adjust the freeplay, loosen the lock nut (1) and turn the adjuster (2).

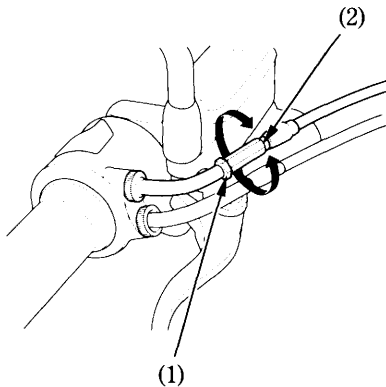

(1) Lock nut

(2) Adjuster

COOLANT

Refer to the Safety Precautions on page 62 .

Coolant Replacement

Coolant should be replaced by a Honda dealer, unless the owner has proper tools and service data and is mechanically qualified. Refer to an official Honda Shop Manual.

Always add coolant to the reserve tank. Do not attempt to add coolant by removing the radiator cap.

WARNING

Removing the radiator cap while the engine is hot can cause the coolant to spray out, seriously scalding you.

Always let the engine and radiator cool down before removing the radiator cap.

AIR CLEANER

Refer to the Safety Precautions on page 62 .

The air cleaner should be serviced at regular intervals (page 64). Service more frequently when riding in unusually wet or dusty areas.

1. Remove the bolts (1) and the air cleaner housing cover (2).
2. Remove and discard the air cleaner (3).
3. Thoroughly clean the inside of the air cleaner housing (4).
4. Install a new air cleaner.

Use the Honda Genuine air cleaner or an equivalent air cleaner specified for your model. Using the wrong Honda air cleaner or a non-Honda air cleaner which is not of equivalent quality may cause premature engine wear or performance problems.

5. Install the removed parts in the reverse order of removal.

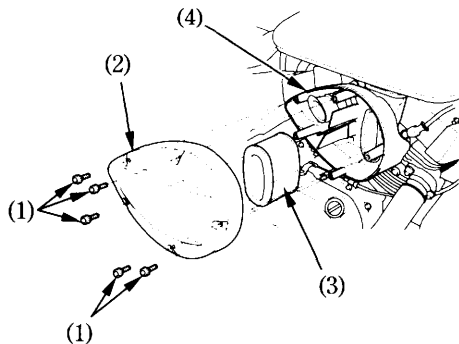

- (1) Bolts
- (2) Air cleaner housing cover
- (3) Air cleaner
- (4) Air cleaner housing

FRONT AND REAR SUSPENSION INSPECTION

Refer to the Safety Precautions on page 62 .

1. Check the fork assembly by locking the front brake and pumping the fork up and down vigorously. Suspension action should be smooth and there must be no oil leakage.
2. Swingarm bearings should be checked by pushing hard against the side of the rear wheel while the motorcycle is on a support block. Freeplay indicates worn bearings.
3. Carefully inspect all front and rear suspension fasteners for tightness.

SIDE STAND

Refer to the Safety Precautions on page 62 .

Perform the following maintenance in accordance with the maintenance schedule.

Functional Check:

- Check the side stand spring (1) for damage or loss of tension and the side stand assembly for freedom of movement.
- Check the side stand ignition cut-off system:
 1. Sit astride the motorcycle; put the side stand up and the transmission in neutral.
 2. Start the engine and with the clutch lever pulled in, shift the transmission into gear.
 3. Lower the side stand. The engine should stop as you put the side stand down.

If the side stand system does not operate as described, see your Honda dealer for service.

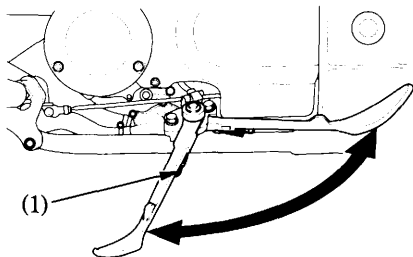

(1) Side stand spring

WHEEL REMOVAL

Refer to the Safety Precautions on page 62 .

This motorcycle is equipped with a side stand only. Therefore, if front or rear wheel removal is required, it will be necessary to raise the center of the motorcycle with a jack or other firm support. If none is available, see your Honda dealer for this service.

Front Wheel Removal

1. Raise the front wheel off the ground by placing a support block under the engine.
2. Loosen the right and left axle pinch bolts (1), and remove the front axle bolt (2).

Do not depress the brake lever when the wheel is off the motorcycle. The caliper pistons will be forced out of the cylinders with subsequent loss of brake fluid. If this occurs, servicing of the brake system will be necessary. See your Honda dealer for this service.

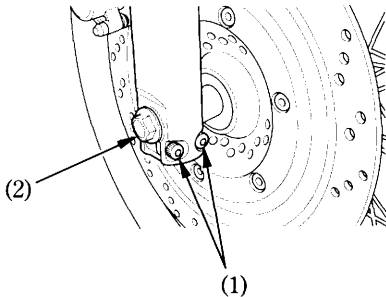

- (1) Axle pinch bolts
(2) Front axle bolt

3. Remove the front axle shaft (3), front wheel and side collars.

Avoid getting grease, oil, or dirt on the disc or pad surfaces. Any contamination can cause poor brake performance or rapid pad wear after reassembly.

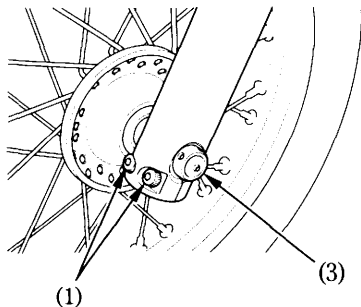

- (1) Axle pinch bolts
(3) Front axle shaft

Installation:

1. Install the side collars into the left and right side wheel hub.

Position the front wheel between the fork legs and insert the front axle shaft from the left side, through the left fork leg and wheel hub.

To avoid damaging the brake pads, carefully fit the brake disc (4) between the pads.

2. Align the index line (5) of the front axle shaft with the surface (6) of the fork leg.

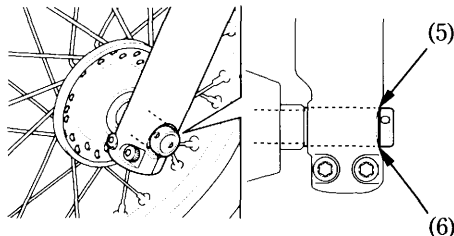

(5) Index line

(6) Surface

3. Tighten the axle pinch bolts on the left fork leg to the specified torque:
22 N·m (2.2 kgf·m , 16 lbf·ft)
4. Tighten the axle bolt to the specified torque:
59 N·m (6.0 kgf·m , 44 lbf·ft)
5. Operate the front brake and pump the fork several times.
Check for free wheel rotation after the brake lever is released. Recheck the wheel if the brake drags or if the wheel does not rotate freely.
6. If the clearances between each surface of the brake disc and the brake bracket (7) (not the brake pads) are symmetrical, follow next step.
If the clearances are not symmetrical, loosen the left axle pinch bolts and pull the left fork outward or push inward to adjust the clearance. Then follow the next step.

7. Tighten the axle pinch bolts on the right fork leg to specified torque:

22 N·m (2.2 kgf·m , 16 lbf·ft)

- Visually check that the clearances between each surface of the brake disc and the brake bracket (not the brake pads) are symmetrical.

If the torque wrench was not used for installation, see your Honda dealer as soon as possible to verify proper assembly. Improper assembly may lead to loss of braking capacity.

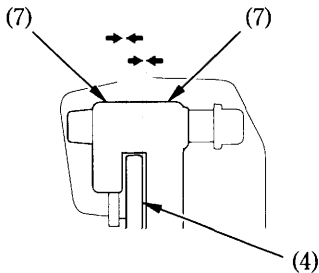

(4) Brake disc

(7) Brake bracket