

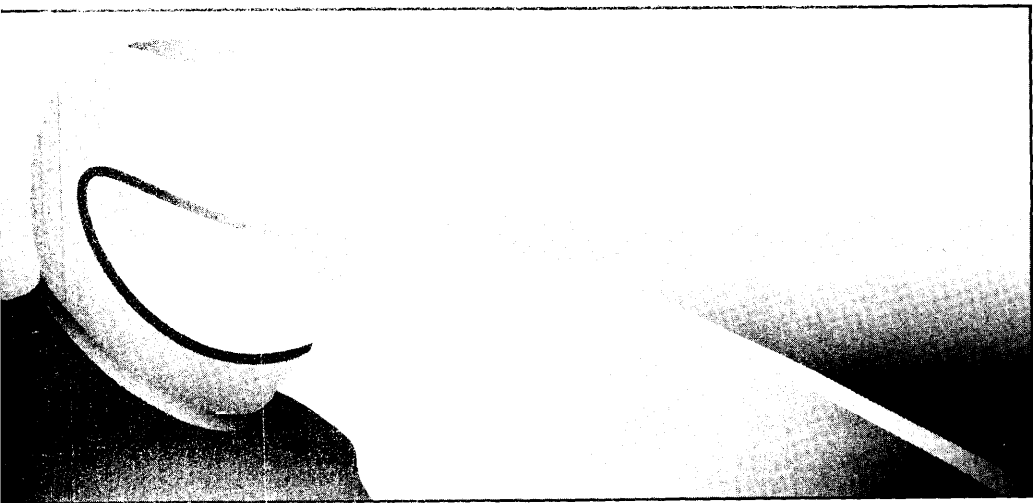

**OWNER'S MANUAL  
MANUEL DU CONDUCTEUR  
FAHRER-HANDBUCH**



**VTX1800C  
VTX**



**Honda VTX1800C**

**OWNER'S MANUAL**

**MANUEL DU CONDUCTEUR**

**FAHRER-HANDBUCH**

© Honda Motor Co., Ltd. 2001

## **IMPORTANT INFORMATION**

- **OPERATOR AND PASSENGER**

This motorcycle is designed to carry the operator and one passenger. Never exceed the maximum weight capacity as shown on the accessories and loading label.

- **ON-ROAD USE**

This motorcycle is designed to be used only on the road.

- **READ THIS OWNER'S MANUAL CAREFULLY**

Pay special attention to the safety messages that appear throughout the manual. These messages are fully explained in the "Safety Messages" section which appears opposite the Contents page.

This manual should be considered a permanent part of the motorcycle and should remain with the motorcycle when resold.

# **Honda VTX1800C OWNER'S MANUAL**

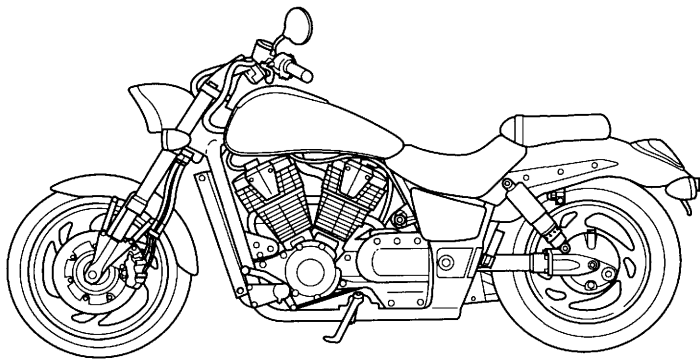

**All information in this publication is based on the latest production information available at the time of approval for printing. Honda Motor Co.,Ltd. reserves the right to make changes at any time without notice and without incurring any obligation.**

**No part of this publication may be reproduced without written permission.**

## WELCOME

The motorcycle presents you a challenge to master the machine, a challenge to adventure. You ride through the wind, linked to the road by a vehicle that responds to your commands as no other does. Unlike an automobile, there is no metal cage around you. Like an airplane, a pre-ride inspection and regular maintenance are essential to your safety. Your reward is freedom.

To meet the challenges safely, and to enjoy the adventure fully, you should become thoroughly familiar with this owner's manual **BÉFORE YOU RIDE THE MOTORCYCLE**.

As you read this manual, you will find information that is preceded by a **NOTICE** symbol. This information is intended to help you avoid damage to your motorcycle, other property, or the environment.

When service is required, remember that your Honda dealer knows your motorcycle best. If you have the required mechanical "know-how" and tools, your dealer can supply you with an official Honda Service Manual to help you perform many maintenance and repair tasks.

Pleasant riding, and thank you for choosing a Honda !

- Following codes in this manual indicate each country.

E	UK	F	France	U	Australia
ED	( European direct sales )		Austria		Holland
	Belgium		Switzerland		Spain
	Germany		Italy		Portugal

- The specifications may vary with each locale.

## A FEW WORDS ABOUT SAFETY

Your safety, and the safety of others, is very important. And operating this motorcycle safely is an important responsibility.

To help you make informed decisions about safety, we have provided operating procedures and other information on labels and in this manual. This information alerts you to potential hazards that could hurt you or others.

Of course, it is not practical or possible to warn you about all hazards associated with operating or maintaining a motorcycle. You must use your own good judgment.

You will find important safety information in a variety of forms, including:

- **Safety Labels** — on the motorcycle.
- **Safety Messages** — preceded by a safety alert symbol  and one of three signal words: **DANGER, WARNING, or CAUTION.**

These signal words mean:

**▲ DANGER**

You **WILL** be **KILLED** or **SERIOUSLY HURT** if you don't follow instructions.

**▲ WARNING**

You **CAN** be **KILLED** or **SERIOUSLY HURT** if you don't follow instructions.

**▲ CAUTION**

You **CAN** be **HURT** if you don't follow instructions.

- **Safety Headings** — such as Important Safety Reminders or Important Safety Precautions.
- **Safety Section** — such as Motorcycle Safety.
- **Instructions** — how to use this motorcycle correctly and safely.

This entire manual is filled with important safety information — please read it carefully.

# OPERATION

page

- 1 MOTORCYCLE SAFETY
- 1 Important Safety Information
- 2 Protective Apparel
- 4 Load Limits and Guidelines

## 8 PARTS LOCATION

- 11 Instruments and Indicators

## 16 MAJOR COMPONENTS

(Information you need to operate this motorcycle)

- 16 Suspension
- 17 Brakes
- 19 Clutch
- 20 Coolant
- 22 Fuel
- 25 Engine Oil
- 26 Final Drive Oil
- 27 Tubeless Tyres

page

- 33 ESSENTIAL INDIVIDUAL COMPONENTS
- 33 Ignition Switch
- 34 Right Handlebar Controls
- 35 Left Handlebar Controls

page

36	<b>FEATURES</b> (Not required for operation)
36	Steering Lock
37	Helmet Holder
38	Document Compartment
39	Side Cover
40	Seat
41	Headlight Aim Vertical Adjustment

page

42	<b>OPERATION</b>
42	Pre-ride Inspection
43	Starting the Engine
46	Running-in
47	Riding
49	Braking
51	Parking
52	Anti-theft Tips

# MAINTENANCE

page

53	MAINTENANCE
53	The Importance of Maintenance
54	Maintenance Safety
55	Safety Precautions
56	Maintenance Schedule
59	Tool Kit
60	Serial Numbers
61	Colour Label
62	Engine Oil
66	Crankcase Breather
67	Spark Plugs
70	Final Drive Oil
71	Throttle Operation
72	Idle Speed
73	Coolant
74	Air Cleaner
75	Front and Rear Suspension Inspection
76	Side Stand
77	Wheel Removal
83	Brake Pad Wear
85	Battery
87	Fuse Replacement

page

90	Stoplight Switch Adjustment
91	Bulb Replacement
96	CLEANING
99	STORAGE GUIDE
99	Storage
101	Removal from Storage
102	SPECIFICATIONS
106	CATALYTIC CONVERTER
107	NOISE CONTROL SYSTEM (AUSTRALIA ONLY)

# **MOTORCYCLE SAFETY**

## **IMPORTANT SAFETY INFORMATION**

Your motorcycle can provide many years of service and pleasure – if you take responsibility for your own safety and understand the challenges that you can meet on the road.

There is much that you can do to protect yourself when you ride. You'll find many helpful recommendations throughout this manual. Following are a few that we consider most important.

### **Always Wear a Helmet**

It's a proven fact: Helmets significantly reduce the number and severity of head injuries. So always wear a helmet and make sure your passenger does the same. We also recommend that you wear eye protection, sturdy boots, gloves and other protective gear (page 2 ).

### **Make Yourself Easy to See**

Some drivers do not see motorcycles because they are not looking for them. To make yourself more visible, wear bright reflective clothing, position yourself so other drivers can see you, signal before turning or changing lanes, and use your horn when it will help others notice you.

### **Ride Within Your Limits**

Pushing the limits is another major cause of motorcycle accidents. Never ride beyond your personal abilities or faster than conditions warrant. Remember that alcohol, drugs, fatigue and inattention can significantly reduce your ability to make good judgements and ride safely.

## Keep Your Bike in Safe Condition

For safe riding, it's important to inspect your motorcycle before every ride and perform all recommended maintenance. Never exceed load limits, and only use accessories that have been approved by Honda for this motorcycle. See page 4 for more details.

## PROTECTIVE APPAREL

For your safety, we strongly recommend that you always wear an approved motorcycle helmet, eye protection, boots, gloves, long pants, and a long-sleeved shirt or jacket whenever you ride. Although complete protection is not possible, wearing proper gear can reduce the chance of injury when you ride.

Following are suggestions to help you choose proper gear.

### **WARNING**

Not wearing a helmet increases the chance of serious injury or death in a crash.

Be sure you and your passenger always wear a helmet, eye protection and other protective apparel when you ride.

## **Helmets and Eye Protection**

Your helmet is your most important piece of riding gear because it offers the best protection against head injuries. A helmet should fit your head comfortably and securely. A bright-colored helmet can make you more noticeable in traffic, as can reflective strips.

An open-face helmet offers some protection, but a full-face helmet offers more. Always wear a face shield or goggles to protect your eyes and help your vision.

## **Additional Riding Gear**

In addition to a helmet and eye protection, we also recommend:

- Sturdy boots with non-slip soles to help protect your feet and ankles.
- Leather gloves to keep your hands warm and help prevent blisters, cuts, burns and bruises.
- A motorcycle riding suit or jacket for comfort as well as protection. Bright-colored and reflective clothing can help make you more noticeable in traffic. Be sure to avoid loose clothes that could get caught on any part of your motorcycle.

## **LOAD LIMITS AND GUIDELINES**

Your motorcycle has been designed to carry you and one passenger. When you carry a passenger, you may feel some difference during acceleration and braking. But so long as you keep your motorcycle well-maintained, with good tyres and brakes, you can safely carry loads within the given limits and guidelines.

However, exceeding the weight limit or carrying an unbalanced load can seriously affect your motorcycle's handling, braking and stability. Non-Honda accessories, improper modifications, and poor maintenance can also reduce your safety margin.

The following pages give more specific information on loading, accessories and modifications.

## **Loading**

How much weight you put on your motorcycle, and how you load it, are important to your safety. Anytime you ride with a passenger or cargo you should be aware of the following information.

### **⚠ WARNING**

Overloading or improper loading can cause a crash and you can be seriously hurt or killed.

Follow all load limits and other loading guidelines in this manual.

## **Load Limits**

Following are the load limits for your motorcycle:

### **Maximum weight capacity:**

197 kg (434 lbs)

Includes the weight of the rider, passenger, all cargo and all accessories

### **Maximum cargo weight:**

18 kg (40 lbs)

## **Loading Guidelines**

Your motorcycle is primarily intended for transporting you and a passenger. You may wish to secure a jacket or other small items to the seat when you are not riding with a passenger.

If you wish to carry more cargo, check with your Honda dealer for advice, and be sure to read the information regarding accessories on page 6 .

Improperly loading your motorcycle can affect its stability and handling. Even if your motorcycle is properly loaded, you should ride at reduced speeds and never exceed 130 km/h (80 mph) when carrying cargo.

Follow these guidelines whenever you carry a passenger or cargo:

- Check that both tyres are properly inflated.
- If you change your normal load, you may need to adjust the rear suspension (page 16 ).
- To prevent loose items from creating a hazard, make sure that all cargo is securely tied down before you ride away.
- Place cargo weight as close to the center of the motorcycle as possible.
- Balance cargo weight evenly on both sides.

## Accessories and Modifications

Modifying your motorcycle or using non-Honda accessories can make your motorcycle unsafe. Before you consider making any modifications or adding an accessory, be sure to read the following information.

### **WARNING**

Improper accessories or modifications can cause a crash in which you can be seriously hurt or killed.

Follow all instructions in this owner's manual regarding accessories and modifications.

## Accessories

We strongly recommend that you use only genuine Honda accessories that have been specifically designed and tested for your motorcycle. Because Honda cannot test all other accessories, you must be personally responsible for proper selection, installation and use of non-Honda accessories. Check with your dealer for assistance and always follow these guidelines:

- Make sure the accessory does not obscure any lights, reduce ground clearance and banking angle, limit suspension travel or steering travel, alter your riding position or interfere with operating any controls.
- Be sure electrical equipment does not exceed the motorcycle's electrical system capacity (page 88 ). A blown fuse can cause a loss of lights or engine power.

- Do not pull a trailer or sidecar with your motorcycle. This motorcycle was not designed for these attachments, and their use can seriously impair your motorcycle's handling.

### **Modifications**

We strongly advise you not to remove any original equipment or modify your motorcycle in any way that would change its design or operation. Such changes could seriously impair your motorcycle's handling, stability and braking, making it unsafe to ride.

Removing or modifying your lights, mufflers, emission control system or other equipment can also make your motorcycle illegal.

## PARTS LOCATION

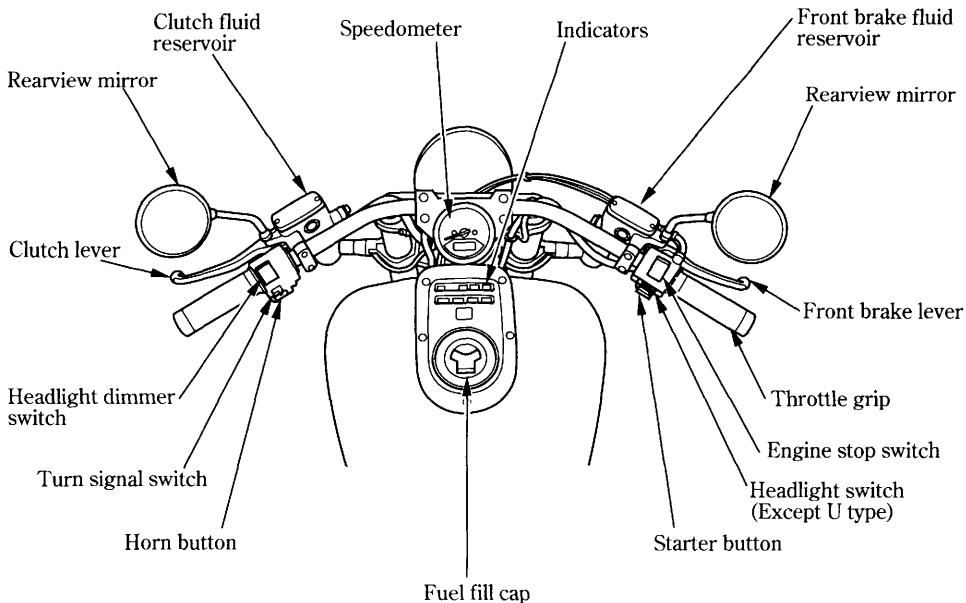

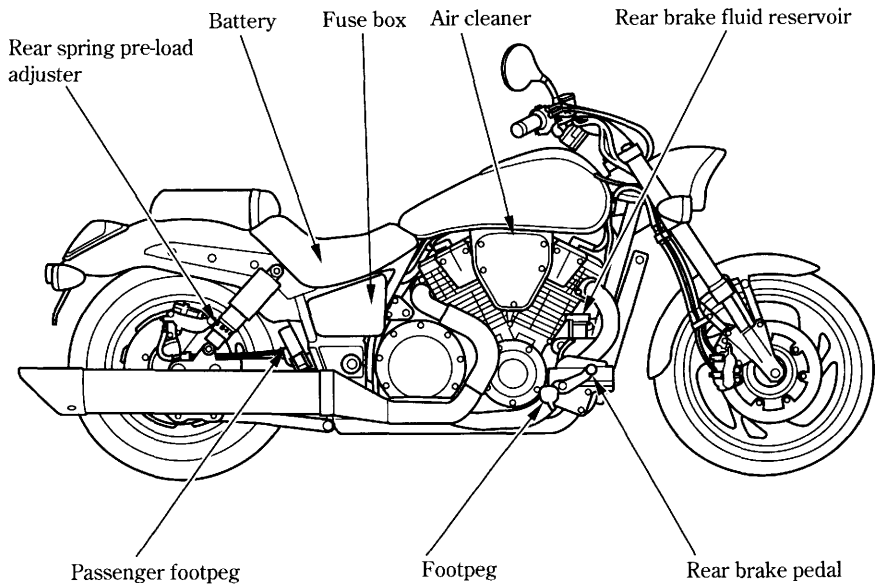

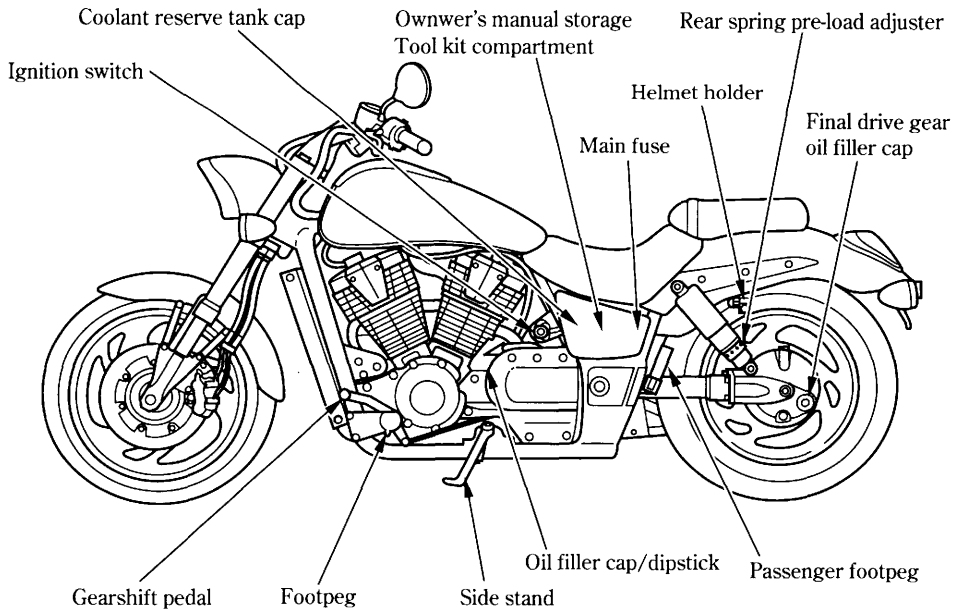

## INSTRUMENTS AND INDICATORS

The indicators are contained on the fuel tank. Their functions are described in the tables on the following pages.

- (1) Speedometer
- (2) Odometer/tripmeter display
- (3) Fuel indicator
- (4) Neutral indicator
- (5) Low oil pressure indicator
- (6) PGM-FI indicator
- (7) Turn signal indicator
- (8) Coolant temperature indicator
- (9) High beam indicator
- (10) Odometer/tripmeter select and reset button

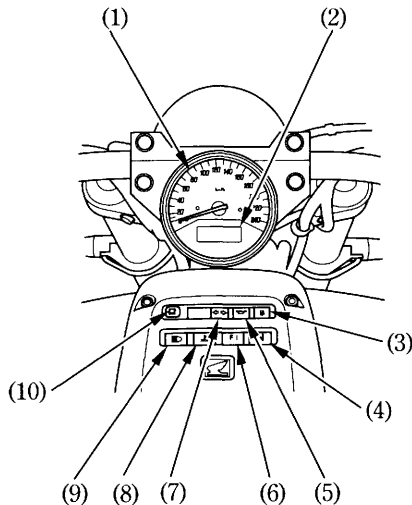

<b>(Ref.No.) Description</b>	<b>Function</b>
(1) Speedometer	Shows riding speed.
(2) Odometer/Tripmeter display	ODO: shows accumulated mileage. TRIP: shows mileage per trip.
(3) Fuel indicator	Lights when there is only few fuel left in the fuel tank. The amount of fuel left in the tank when lights and with the vehicle set upright is approximately: 3.0 ℓ (0.79 US gal , 0.66 Imp gal)
(4) Neutral indicator (green)	Lights when the transmission is in neutral.
(5) Low oil pressure indicator (red)	<p>Lights when the engine oil pressure is below normal operating range. Should light when ignition switch is ON and engine is not running. Should go out when the engine starts, except for occasional flickering at or near idling speed when engine is warm.</p> <p><b>NOTICE</b></p> <p>Running the engine with insufficient oil pressure may cause serious engine damage.</p>

<b>(Ref.No.) Description</b>	<b>Function</b>
(6) PGM-FI indicator (red)	<p>Flashes when there is any abnormality in the PGM-FI (Programmed Fuel Injection) system. Should also light for a few seconds and then go off when the ignition switch is turned ON and engine stop switch is at ○ (RUN).</p> <p>If it comes on at any other time , reduce speed and take the motorcycle to your Honda dealer as soon as possible.</p>
(7) Turn signal indicator	Flashes when the either turn signal operates.
(8) Coolant temperature indicator (red)	<p>Lights when the coolant is over the specified temperature. If the indicator goes on while riding, stop the engine and check the reserve tank coolant level. Read pages 20 – 21 and do not ride the motorcycle until the problem has been corrected.</p> <p><b>NOTICE</b></p> <p>Exceeding maximum running temperature may cause serious engine damage.</p>

<b>(Ref.No.) Description</b>	<b>Function</b>
(9) High beam indicator (blue)	Lights when the headlight is on high beam.
(10) Odometer/Tripmeter select and reset button	This button is used to reset the tripmeter or to select the tripmeter or odometer (page 15 ).

## Odometer/Tripmeter Display

The display (1) has two functions, odometer and tripmeter.

Push the button (2) to select “ODO” or “TRIP” mode.

To reset the tripmeter, push and hold the button when the display is in the “TRIP” mode.

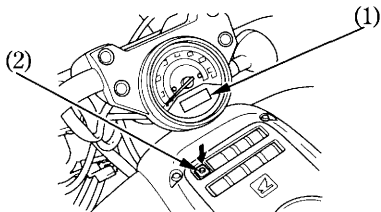

- (1) Odometer/Tripmeter display
- (2) Odometer/Tripmeter select and reset button

Odometer

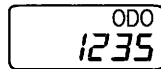

Tripmeter

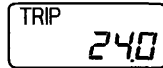

Tripmeter reset

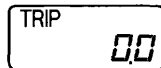

## MAJOR COMPONENTS

### (Information you need to operate this motorcycle)

#### SUSPENSION

Each shock absorber (1) has 5 adjustment positions for different load or riding conditions.

Use a pin spanner (2) to adjust the rear shocks.

Position 1 is for light loads and smooth road conditions. Positions 2 to 5 increase spring preload for a stiffer rear suspension, and can be used when the motorcycle is heavily loaded. Be certain to adjust both shock absorbers to the same position.

Standard position: 2

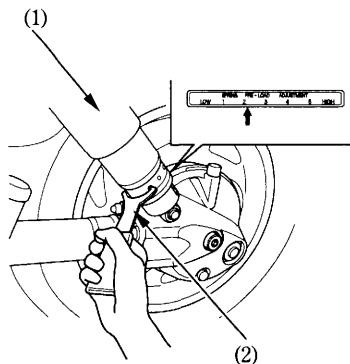

(1) Shock absorber

(2) Pin spanner

## **BRAKES**

Both the front and rear brakes are the hydraulic disc types.

As the brake pads wear, the brake fluid level drops.

There are no adjustments to perform, but fluid level and pad wear must be inspected periodically. The system must be inspected frequently to ensure there are no fluid leaks. If the control lever or pedal free travel becomes excessive and the brake pads are not worn beyond the recommended limit (page 83 ), there is probably air in the brake system and it must be bled. See your Honda dealer for this service.

### Front Brake Fluid Level:

With the motorcycle in an upright position, check the fluid level. It should be above the LOWER level mark (1). If the level is at or below the LOWER level mark (1), check the brake pads for wear (page 83 ).

Worn pads should be replaced. If the pads are not worn, have your brake system inspected for leaks.

The recommended brake fluid is Honda DOT 4 brake fluid from a sealed container, or an equivalent.

### **Front**

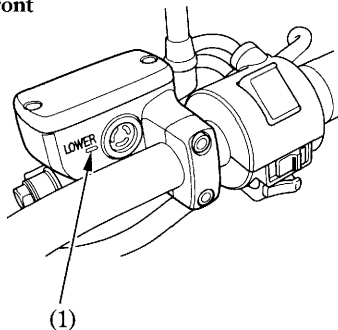

(1) LOWER level mark

### Rear Brake Fluid Level:

With the motorcycle in an upright position, check the fluid level. It should be between the UPPER (1) and LOWER (2) level marks. If the level is at or below the LOWER level mark (2), check the brake pads for wear (page 83 ).

Worn pads should be replaced. If the pads are not worn, have your brake system inspected for leaks.

The recommended brake fluid is Honda DOT 4 brake fluid from a sealed container, or an equivalent.

### **Rear**

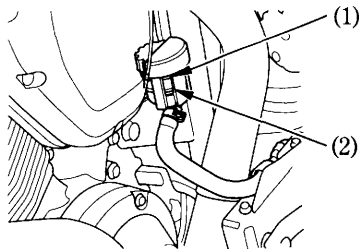

- (1) UPPER level mark
- (2) LOWER level mark

### Other Checks:

Make sure there are no fluid leaks. Check for deterioration or cracks in the hoses and fittings.

## CLUTCH

This motorcycle has a hydraulically actuated clutch. There are no adjustments to perform but the clutch system must be inspected periodically for fluid level and leakage. If the control lever freeplay becomes excessive and the motorcycle creeps or stalls when shifted into gear, or if the clutch slips, causing acceleration to lag behind engine speed, there is probably air in the clutch system and it must be bled out. See your Honda dealer for this service.

### Fluid Level:

Check that the fluid level is above the LOWER level mark (1) with the motorcycle in an upright position. If the fluid level is near the lower level line, it indicates fluid leakage. See your Honda dealer.

### Other Checks:

Make sure there are no fluid leaks. Check for deterioration or cracks in the hoses and fittings.

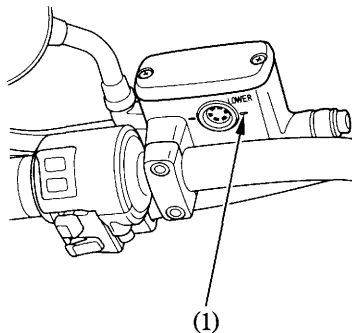

(1) LOWER level mark

## **COOLANT**

### **Coolant Recommendation**

The owner must properly maintain the coolant to prevent freezing, overheating, and corrosion. Use only high quality ethylene glycol antifreeze containing corrosion protection inhibitors specifically recommended for use in aluminum engines. (SEE ANTIFREEZE CONTAINER LABEL).

Use only low-mineral drinking water or distilled water as a part of the antifreeze solution. Water that is high in mineral content or salt may be harmful to the aluminum engine.

Using coolant with silicate inhibitors may cause premature wear of water pump seals or blockage of radiator passages.

Using tap water may cause engine damage.

The factory provides a 50/50 solution of antifreeze and distilled water in this motorcycle. This coolant solution is recommended for most operating temperatures and provides good corrosion protection. A higher concentration of antifreeze decreases the cooling system performance and is recommended only when additional protection against freezing is needed. A concentration of less than 40/60 (40% antifreeze) will not provide proper corrosion protection. During freezing temperatures, check the cooling system frequently and add higher concentrations of antifreeze (up to a maximum of 60% antifreeze) if required.

## Inspection

The reserve tank is under the crankcase.

Check the coolant level in the reserve tank (1) while the engine is at the normal operating temperature with the motorcycle in an upright position. If the coolant level is below the LOWER level mark (3), remove the left side cover (page 39) and the reserve tank cap (4).

Add coolant mixture until it reaches the UPPER level mark (2). Always add coolant to the reserve tank.

Do not attempt to add coolant by removing the radiator cap.

If the reserve tank is empty, or if coolant loss is excessive, check for leaks and see your Honda dealer for repair.

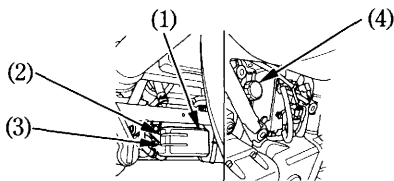

- |                      |                      |
|----------------------|----------------------|
| (1) Reserve tank     | (3) LOWER level mark |
| (2) UPPER level mark | (4) Reserve tank cap |

## FUEL

### Fuel Tank

The fuel tank capacity including the reserve supply is:

17.0 ℓ (4.49 US gal , 3.74 Imp gal)

To open the fuel fill cap (1), insert the ignition key (2) and turn it clockwise. The fuel fill cap is hinged and will lift up.

Do not overfill the tank. There should be no fuel in the filler neck (3).

After refueling, to close the fuel fill cap, push the fuel fill cap into the filler neck until it snaps closed and locks. Remove the key.

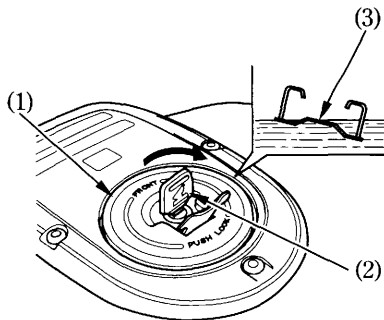

## ⚠ WARNING

Petrol is highly flammable and explosive. You can be burned or seriously injured when handling fuel.

- Stop the engine and keep heat, sparks, and flame away.
- Refuel only outdoors.
- Wipe up spills immediately.

- (1) Fuel fill cap  
(2) Ignition key

- (3) Filler neck

Use unleaded petrol with a research octane number of 91 or higher.

The use of leaded petrol will cause premature damage to the catalytic converter.

#### **NOTICE**

If “spark knock” or “pinking” occurs at a steady engine speed under normal load, change brands of petrol. If spark knock or pinking persists, consult your Honda dealer. Failure to do so is considered misuse, and damage caused by misuse is not covered by Honda’s Limited Warranty.

## **Petrol Containing Alcohol**

If you decide to use a petrol containing alcohol (gasohol), be sure it's octane rating is at least as high as that recommended by Honda. There are two types of "gasohol": one containing ethanol, and the other containing methanol. Do not use petrol that contains more than 10 % ethanol. Do not use petrol containing methanol (methyl or wood alcohol) that does not also contain cosolvents and corrosion inhibitors for methanol. Never use petrol containing more than 5 % methanol, even if it has cosolvents and corrosion inhibitors.

Fuel system damage or engine performance problems resulting from the use of fuels that contain alcohol is not covered under the warranty. Honda cannot endorse the use of fuels containing methanol since evidence of their suitability is as yet incomplete.

Before buying fuel from an unfamiliar station, try to find out if the fuel contains alcohol. If it does, confirm the type and percentage of alcohol used. If you notice any undesirable operating symptoms while using a petrol that contains alcohol, or one that you think contains alcohol, switch to a petrol that you know does not contain alcohol.

## ENGINE OIL

### Engine Oil Level Check

Check the engine oil level each day before riding the motorcycle.

The level must be maintained between the upper (1) and lower (2) level marks on the dipstick (3).

1. Start the engine and let it idle for a few minutes. Make sure the red low oil pressure indicator goes off. If the light remains on, stop the engine immediately.
2. Stop the engine and hold the motorcycle in an upright position on firm, level ground.
3. After a few minutes, remove the oil filler cap/dipstick, wipe it clean, and reinsert the dipstick without screwing it in. Remove the dipstick. The oil level should be between the upper and lower marks on the dipstick.
4. If required, add the specified oil (see page 62) up to the upper level mark. Do not overfill.

5. Reinstall the oil filler cap/dipstick. Check for oil leaks.

### NOTICE

Running the engine with insufficient oil pressure may cause serious engine damage.

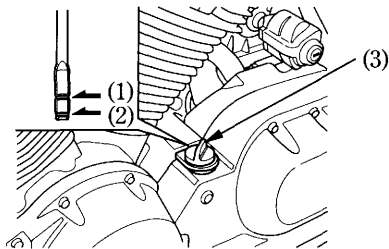

- (1) UPPER level mark
- (2) LOWER level mark
- (3) Oil filler cap/dipstick

## FINAL DRIVE OIL

### Oil Level Check

Check the final drive oil level when specified by the maintenance schedule (page 58 ).

1. Place the motorcycle on its side stand.
2. Remove the oil filler cap (1 ).
3. Check that the oil level reaches the lower edge of the oil cap hole (2 ).

If the level is low, check for leaks. Pour fresh oil through the oil filler hole until it reaches the lower edge of the opening.

**Recommended Oil:**  
**HYPOID GEAR OIL SAE 80**

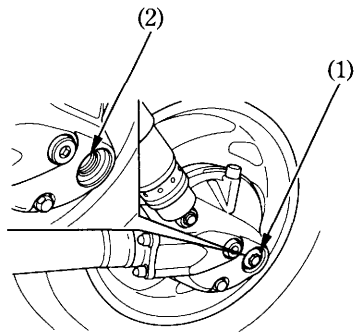

(1) Oil filler cap

(2) Oil cap hole

## TUBELESS TYRES

To safely operate your motorcycle, your tyres must be the proper type and size, in good condition with adequate tread, and correctly inflated for the load you are carrying. The following pages give more detailed information on how and when to check your air pressure, how to inspect your tyres for damage, and what to do when your tyres need to be repaired or replaced.

### **WARNING**

Using tyres that are excessively worn or improperly inflated can cause a crash in which you can be seriously hurt or killed.

Follow all instructions in this owner's manual regarding tyre inflation and maintenance.

## Air Pressure

Keeping your tyres properly inflated provides the best combination of handling, tread life and riding comfort. Generally, underinflated tyres wear unevenly, adversely affect handling, and are more likely to fail from being overheated.

Overinflated tyres make your motorcycle ride more harshly, are more prone to damage from road hazards, and wear unevenly.

We recommend that you visually check your tyres before every ride and use a gauge to measure air pressure at least once a month or any time you think the tyres might be low.

Tubeless tyres have some self-sealing ability if they are punctured. However, because leakage is often very slow, you should look closely for punctures whenever a tyre is not fully inflated.

Always check air pressure when your tyres are “cold” – when the motorcycle has been parked for at least three hours. If you check air pressure when your tyres are “warm” – when the motorcycle has been ridden for even a few miles – the readings will be higher than if the tyres were “cold”. This is normal, so do not let air out of the tyres to match the recommended cold air pressures given below. If you do, the tyres will be underinflated.

The recommended “cold” tyre pressures are:

kPa (kgf/cm <sup>2</sup> , psi)		
Driver only	Front	225 (2.25 , 33)
	Rear	225 (2.25 , 33)
Driver and one passenger	Front	225 (2.25 , 33)
	Rear	250 (2.50 , 36)

## Inspection

Whenever you check the tyre pressures, you should also examine the tyre treads and sidewalls for wear, damage, and foreign objects:

Look for:

- Bumps or bulges in the side of the tyre or the tread. Replace the tyre if you find any bumps or bulges.
- Cuts, splits or cracks in the tyre. Replace the tyre if you can see fabric or cord.
- Excessive tread wear.

Also, if you hit a pothole or hard object, pull to the side of the road as soon as you safely can and carefully inspect the tyres for damage.

## Tread Wear

Replace tyres before tread depth at the center of the tyre reaches the following limit:

Minimum tread depth	
Front:	1.5 mm (0.06 in)
Rear:	2.0 mm (0.08 in)

< For Germany >

German law prohibits use of tyres whose tread depth is less than 1.6 mm.

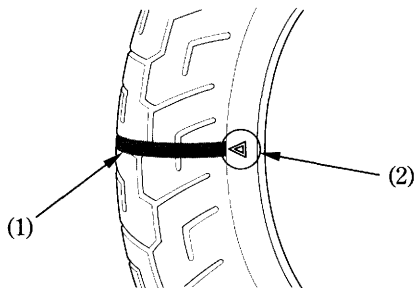

- (1) Wear indicator
- (2) Wear indicator location mark

## **Tyre Repair**

If a tyre is punctured or damaged, you should replace it, not repair it. As discussed below, a tyre that is repaired, either temporarily or permanently, will have lower speed and performance limits than a new tyre.

A temporary repair, such as an external tubeless tyre plug, may not be safe for normal speeds and riding conditions. If a temporary or emergency repair is made to a tyre, you should ride slowly and cautiously to a dealer and have the tyre replaced. If possible, you should not carry a passenger or cargo until a new tyre is installed.

Even if a tyre is professionally repaired with a permanent internal patch plug, it will not be as good as a new tyre. You should not exceed 80 km/h (50 mph) for the first 24 hours, or 130 km/h (80 mph) at any time thereafter. In addition, you may not be able to safely carry as much weight as with a new tyre. Therefore, we strongly recommend that you replace a damaged tyre. If you choose to have a tyre repaired, be sure the wheel is balanced before you ride.

## Tyre Replacement

The tyres that came on your motorcycle were designed to match the performance capabilities of your motorcycle and provide the best combination of handling, braking, durability and comfort.

### **WARNING**

Installing improper tyres on your motorcycle can affect handling and stability. This can cause a crash in which you can be seriously hurt or killed.

Always use the size and type of tyres recommended in this owner's manual.

The recommended tyres for your motorcycle are:

Front: 130/70R18 63H  
DUNLOP  
D251F

Rear: 180/70R16 77H  
DUNLOP  
D251

Whenever you replace a tyre, use one that is equivalent to the original and be sure the wheel is balanced after the new tyre is installed.

### **Important Safety Reminders**

- Do not install a tube inside a tubeless tyre on this motorcycle. Excessive heat build-up can cause the tube to burst.
- Use only tubeless tyres on this motorcycle. The rims are designed for tubeless tyres, and during hard acceleration or braking, a tube-type tyre could slip on the rim and cause the tyre to rapidly deflate.

# ESSENTIAL INDIVIDUAL COMPONENTS

## IGNITION SWITCH

The ignition switch (1) is in front of the left side cover.

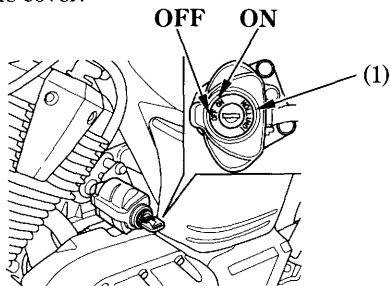

(1) Ignition switch

You should received a key number plate (2) with your key.

You will need this key number if you ever have to replace a lost key. Store this plate in a safe place.

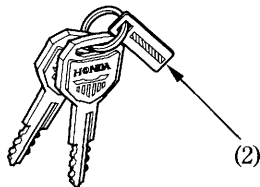



(2) Key number plate



Key Position	Function	Key Removal
OFF	Engine and lights cannot be operated.	Key can be removed
ON	Engine and light can be operated.	Key cannot be removed

## RIGHT HANDLEBAR CONTROLS

### Engine Stop Switch

The engine stop switch (1) is next to the throttle grip. When the switch is in the  (RUN) position, the engine will operate. When the switch is in the  (OFF) position, the engine will not operate. This switch is intended primarily as a safety or emergency switch and should normally remain in the  (RUN) position.

### Headlight Switch < Except U type >

The headlight switch (2) has three positions; ,  and OFF marked by a dot to the right of .

 : Headlight, taillight, position light and meter lights on.

 : Position light, taillight and meter lights on.

OFF(dot): Headlight, taillight, position light and meter lights off.

### Starter Button

The starter button (3) is below the headlight switch (2).

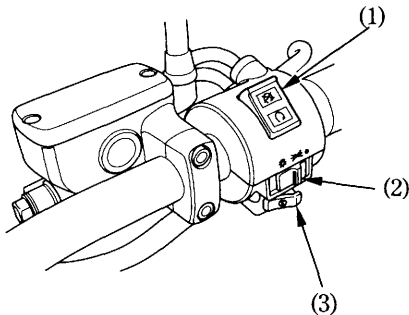

When the starter button is pressed, the starter motor cranks the engine. If the engine stop switch is in the  (OFF) position, the starter motor will not operate. See page 44 for the starting procedure.





- (1) Engine stop switch
- (2) Headlight switch
- (3) Starter button

## LEFT HANDLEBAR CONTROLS

### Headlight Dimmer Switch (1)

Push the dimmer switch to  (HI) to select high beam or to  (LO) to select low beam.

### Turn Signal Switch (2)

Move to  (L) to signal a left turn,  (R) to signal a right turn. Press to turn signal off.

### Horn Button (3)

Press the button to sound the horn.

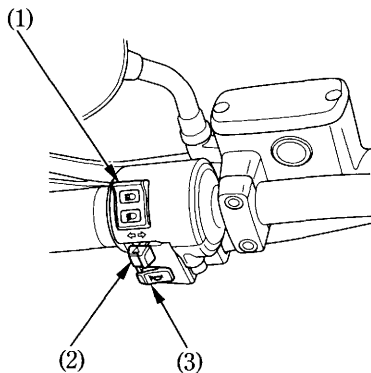

- (1) Headlight dimmer switch
- (2) Turn signal switch
- (3) Horn button

## FEATURES

### (Not required for operation)

#### STEERING LOCK

The steering lock (1) is on the steering column.

To lock the steering, turn the handlebar all the way to the left, insert the steering key into the lock, turn the key counterclockwise as far as possible. Then, press the lock all the way in, turn the key back to the original position, and remove the key.

To unlock the steering, perform the locking sequence in the reverse order.

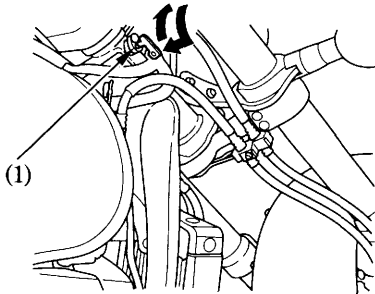

(1) Steering lock

## HELMET HOLDER

The helmet holder (1) is on the left side below the seat. The helmet holder is designed to secure your helmet while parked.

Insert the ignition key (2) and turn it counterclockwise to unlock.

Hang your helmet on the holder pin (3) and push it in to lock. Remove the key.

### **⚠ WARNING**

Riding with a helmet attached to the holder can interfere with the rear wheel or suspension and could cause a crash in which you can be seriously hurt or killed.

Use the helmet holder only while parked. Do not ride with a helmet secured by the holder.

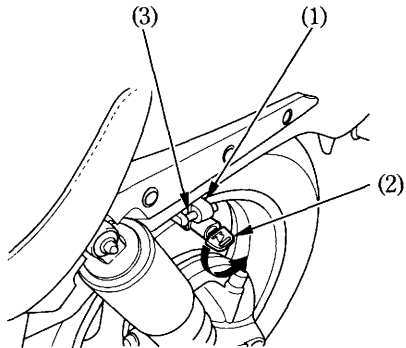

(1) Helmet holder  
(2) Ignition key

(3) Holder pin

## DOCUMENT COMPARTMENT

The document compartment ( 1 ) is behind the left side cover.

Remove the left side cover (page 39 ).

Open the compartment box cover ( 2 ), insert the ignition key ( 3 ) into the lock and turn counterclockwise to unlock the compartment.

This owner's manual and other documents should be stored in this compartment.

When washing your motorcycle, be careful not to flood this area with water.

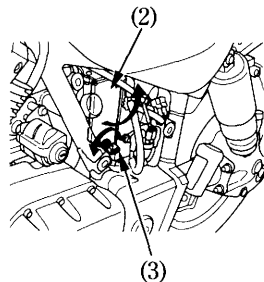
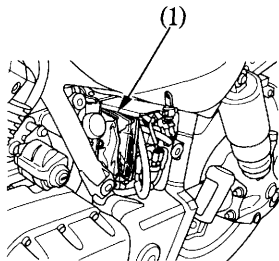

- (1) Document compartment      (3) Ignition key  
(2) Compartment box cover

## SIDE COVER

To remove the right side cover (1) and left side cover (2), pull out the side covers.

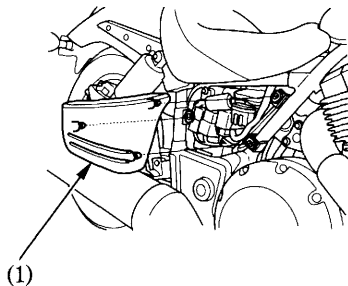

(1) Right side cover

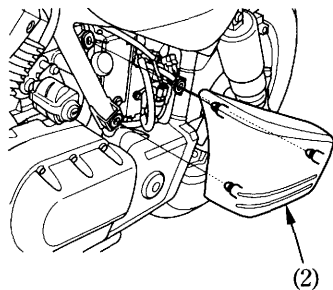

(2) Left side cover

## SEAT

The seat must be removed for battery maintenance.

### Removal:

1. Remove the two bolts (1) and nut (2).
2. Pull the seat assembly (3) back and up.

### Installation:

1. Insert the seat tab (4) into the recess under the frame.
2. Install and tighten the two bolts and nut.

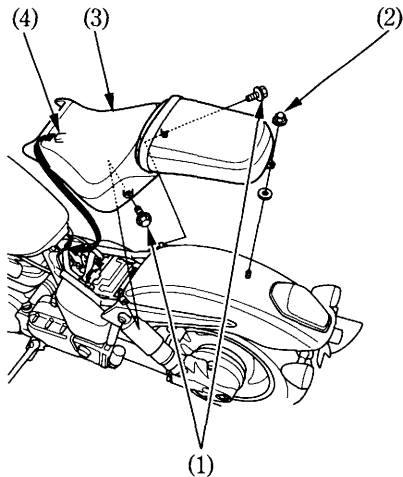

(1) Mounting bolt

(2) Nut

(3) Seat

(4) Tab

## HEADLIGHT AIM VERTICAL ADJUSTMENT

Vertical adjustment can be made by turning the screw (1) in or out as necessary.

Obey local laws and regulations.

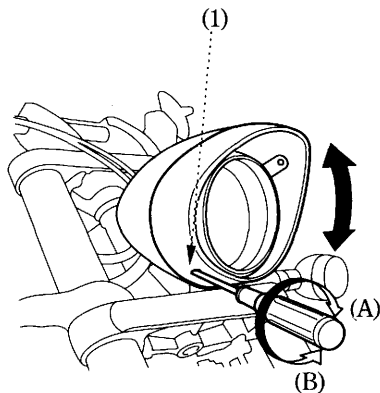

(1) Screw

(A) Up

(B) Down

## OPERATION

### PRE-RIDE INSPECTION

For your safety, it is very important to take a few moments before each ride to walk around your motorcycle and check its condition. If you detect any problem, be sure you take care of it, or have it corrected by your Honda dealer.

#### **WARNING**

Improperly maintaining this motorcycle or failing to correct a problem before riding can cause a crash in which you can be seriously hurt or killed.

Always perform a pre-ride inspection before every ride and correct any problems.

1. Engine oil level—add engine oil if required (page 25 ). Check for leaks.
2. Fuel level—fill fuel tank when necessary (page 22 ). Check for leaks.
3. Front and rear brakes—check operation; make sure there is no brake fluid leakage (pages 17 – 18 ).
4. Tyres—check condition and pressure (pages 27 – 32 ).
5. Throttle—check for smooth opening and full closing in all steering positions.
6. Lights and horn—check that headlight, tail/brake light, turn signals, indicators and horn function properly.
7. Engine stop switch—check for proper function (page 34 ).
8. Side stand ignition cut-off system—check for proper function (page 76 ).

## **STARTING THE ENGINE**

Always follow the proper starting procedure described below.

This motorcycle is equipped with a side stand ignition cut-off system. The engine cannot be started if the side stand is down, unless the transmission is in neutral. If the side stand is up, the engine can be started in neutral or in gear with the clutch lever pulled in. After starting with the side stand down, the engine will shut off if the transmission is put in gear before raising the side stand.

To protect the catalytic converter in your motorcycle's exhaust system, avoid extending idling and the use of leaded petrol.

Your motorcycle's exhaust contains poisonous carbon monoxide gas. High levels of carbon monoxide can collect rapidly in enclosed areas such as a garage. Do not run the engine with the garage door closed. Even with the door open, run the engine only long enough to move your motorcycle out of the garage.

Do not use the electric starter for more than 5 seconds at a time. Release the starter button for approximately 10 seconds before pressing it again.

## Preparation

Before starting, insert the key, turn the ignition switch ON and confirm the following:

- The transmission is in NEUTRAL (neutral indicator light ON).
- The engine stop switch is at  (RUN).
- The red low oil pressure indicator is ON.
- The PGM-FI indicator is OFF.

The low oil pressure indicator should go off a few seconds after the engine starts. If the light stays on, stop the engine immediately and check the engine oil level.

### NOTICE

Operating the engine with insufficient oil pressure can cause serious engine damage.

## Starting Procedure

This motorcycle has a fuel-injected engine with an automatic fast idle. Follow the procedure indicated below.

### Any Air Temperature

- Press the starter button with the throttle completely closed.

The engine will not start if the throttle is fully open (because the electronic control module cuts off the fuel supply).

Snapping the throttle or fast idling for more than about 5 minutes at normal air temperature may cause exhaust pipe discoloration.

### **Flooded Engine**

If the engine fails to start after repeated attempts, it may be flooded engine.

1. Leave the engine stop switch set to  (RUN).
2. Open throttle fully.
3. Press the starter button for 5 seconds.
4. Then follow the normal starting procedure.
5. If the engine start, then open the throttle slightly if idling is unstable.

If the engine does not start, wait for 10 seconds, then follow steps 1–4 again.

### **Ignition Cut Off**

Your motorcycle is designed to automatically stop the engine and fuel pump if the motorcycle is over-turned (a banking sensor cuts off the ignition system). Before restarting the engine, you must turn the ignition switch to the OFF position and then back to ON.

## **RUNNING-IN**

Help assure your motorcycle's future reliability and performance by paying extra attention to how you ride during the first 500 km (300 miles).

During this period, avoid full-throttle starts and rapid acceleration.

## **RIDING**

Review Motorcycle Safety (pages 1 – 7 ) before you ride.

Make sure you understand the function of the side stand mechanism. (See MAINTENANCE SCHEDULE on page 58 and explanation for SIDE STAND on page 76 ).

Make sure flammable materials such as dry grass or leaves do not come in contact with the exhaust system when riding, idling, or parking your motorcycle.

1. After the engine has been warmed up, the motorcycle is ready for riding.
2. While the engine is idling, pull in the clutch lever and depress the gearshift pedal to shift into 1st (low) gear.

3. Slowly release the clutch lever and at the same time gradually increase engine speed by opening the throttle. Coordination of the throttle and clutch lever will assure a smooth positive start.
4. When the motorcycle attains a moderate speed, close the throttle, pull in the clutch lever and shift to 2nd gear by raising the gearshift pedal.  
This sequence is repeated to progressively shift to 3rd, 4th and 5th (top) gears.

5. Coordinate the throttle and brakes for smooth deceleration.
6. Both front and rear brakes should be used at the same time and should not be applied strongly enough to lock the wheel, or braking effectiveness will be reduced and control of the motorcycle be difficult.

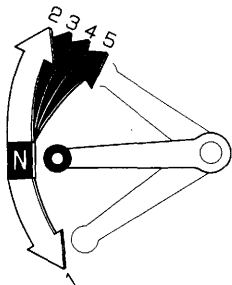

## **BRAKING**

This motorcycle is equipped with a new braking system. Operating the front brake lever applies the front brake. Depressing the rear brake pedal applies the rear brake and a portion of the front brake. For full braking effectiveness, use both the lever and pedal simultaneously, as you would with a conventional motorcycle braking system.

For normal braking, apply both the brake pedal and lever while down-shifting to match your road speed. For maximum braking, close the throttle and firmly apply the pedal and lever; pull in the clutch lever before coming to a complete stop to prevent stalling the engine.

### **Important Safety Reminders:**

- Independent operation of only the brake lever or brake pedal reduces stopping performance.
- Extreme application of the brake controls may cause wheel lock, reducing control of the motorcycle.
- When possible, reduce speed or brake before entering a turn; closing the throttle or braking in mid-turn may cause wheel slip. Wheel slip will reduce control of the motorcycle.

- When riding in wet or rainy conditions, or on loose surfaces, the ability to maneuver and stop will be reduced. All of your actions should be smooth under these conditions. Rapid acceleration, braking or turning may cause loss of control. For your safety, exercise extreme caution when braking, accelerating or turning.
- When descending a long, steep grade, use engine compression braking by downshifting, with intermittent use of both brakes.  
Continuous brake application can overheat the brakes and reduce their effectiveness.
- Riding with your foot resting on the brake pedal or your hand on the brake lever may actuate the brakelight, giving a false indication to other drivers. It may also overheat the brakes, reducing effectiveness.

## **PARKING**

1. After stopping the motorcycle, shift the transmission into neutral, turn the handlebar fully to the left, turn the ignition switch OFF and remove the key.
2. Use the side stand to support the motorcycle while parked.

Park the motorcycle on firm, level ground to prevent it from falling over.

If you must park on a slight incline, aim the front of the motorcycle uphill to reduce the possibility of rolling off the side stand or overturning.

3. Lock the steering to help prevent theft (page 36 ).

Make sure flammable materials such as dry grass or leaves do not come in contact with the exhaust system when parking your motorcycle.

## **ANTI-THEFT TIPS**

1. Always lock the steering and never leave the key in the ignition switch. This sounds simple but people do forget.
2. Be sure the registration information for your motorcycle is accurate and current.
3. Park your motorcycle in a locked garage whenever possible.
4. Use an additional anti-theft device of good quality.
5. Put your name, address, and phone number in this Owner's Manual and keep it on your motorcycles at all times.  
Many times stolen motorcycles are identified by information in the Owner's Manuals that are still with them.

NAME: \_\_\_\_\_

ADDRESS: \_\_\_\_\_

\_\_\_\_\_

\_\_\_\_\_

PHONE NO: \_\_\_\_\_

## MAINTENANCE

### THE IMPORTANCE OF MAINTENANCE

A well-maintained motorcycle is essential for safe, economical and trouble-free riding. It will also help reduce air pollution.

To help you properly care for your motorcycle, the following pages include a Maintenance Schedule and a Maintenance Record for regularly scheduled maintenance.

These instructions are based on the assumption that the motorcycle will be used exclusively for its designed purpose. Sustained high speed operation or operation in unusually wet or dusty conditions will require more frequent service than specified in the Maintenance Schedule. Consult your Honda dealer for recommendations applicable to your individual needs and use.

If your motorcycle overturns or becomes involved in a crash, be sure your Honda dealer inspects all major parts, even if you are able to make some repairs.

### **WARNING**

Improperly maintaining this motorcycle or failing to correct a problem before you ride can cause a crash in which you can be seriously hurt or killed.

Always follow the inspection and maintenance recommendations and schedules in this owner's manual.

## **MAINTENANCE SAFETY**

This section includes instructions on some important maintenance tasks. You can perform some of these tasks with the tools provided — if you have basic mechanical skills.

Other tasks that are more difficult and require special tools are best performed by professionals. Wheel removal should normally be handled only by a Honda technician or other qualified mechanic; instructions are included in this manual only to assist in emergency service.

Some of the most important safety precautions follow. However, we cannot warn you of every conceivable hazard that can arise in performing maintenance. Only you can decide whether or not you should perform a given task.

## **⚠ WARNING**

Failure to properly follow maintenance instructions and precautions can cause you to be seriously hurt or killed.

Always follow the procedures and precautions in this owner's manual.

## SAFETY PRECAUTIONS

- Make sure the engine is off before you begin any maintenance or repairs. This will help eliminate several potential hazards:
  - \* **Carbon monoxide poisoning from engine exhaust.**  
Be sure there is adequate ventilation whenever you operate the engine.
  - \* **Burns from hot parts.**  
Let the engine and exhaust system cool before touching.
  - \* **Injury from moving parts.**  
Do not run the engine unless instructed to do so.
- Read the instructions before you begin, and make sure you have the tools and skills required.
- To help prevent the motorcycle from falling over, park it on a firm, level surface, using the side stand or a maintenance stand to provide support.

- To reduce the possibility of a fire or explosion, be careful when working around petrol or batteries. Use only nonflammable solvent, not petrol, to clean parts. Keep cigarettes, sparks and flames away from the battery and all fuel-related parts.

Remember that your Honda dealer knows your motorcycle best and is fully equipped to maintain and repair it.

To ensure the best quality and reliability, use only new genuine Honda parts or their equivalents for repair and replacement.

## MAINTENANCE SCHEDULE

Perform the Pre-ride Inspection (page 42 ) at each scheduled maintenance period.

I: INSPECT AND CLEAN, ADJUST, LUBRICATE OR REPLACE IF NECESSARY

C: CLEAN R: REPLACE A: ADJUST L: LUBRICATE

The following Maintenance Schedule specifies all maintenance required to keep your motorcycle in peak operating condition. Maintenance work should be performed in accordance with standards and specifications of Honda by properly trained and equipped technicians. Your Honda dealer meets all of these requirements.

- \* Should be serviced by your Honda dealer, unless the owner has the proper tools and service data and is mechanically qualified. Refer to the Official Honda Shop Manual.
- \*\* In the interest of safety, we recommend these items be serviced only by your Honda dealer.

Honda recommends that your Honda dealer should road test your motorcycle after each periodic maintenance is carried out.

- NOTES:
- (1) At higher odometer readings, repeat at the frequency interval established here.
  - (2) Service more frequently if the motorcycle is ridden in unusually wet or dusty areas.
  - (3) Replace every 2 years, or at indicated odometer interval, whichever comes first. Replacement requires mechanical skill.

ITEM	FREQUENCY	WHICHEVER → COMES FIRST ↓ NOTE	ODOMETER READING [NOTE (1)]										Refer to page
			× 1,000 km	1	6	12	18	24	30	36			
			× 1,000 mi	0.6	4	8	12	16	20	24			
			MONTH		6	12	18	24	30	36			
*	FUEL LINE				I		I		I				—
*	THROTTLE OPERATION				I		I		I				71
	AIR CLEANER	NOTE (2)					R				R		74
	SPARK PLUGS				R		R		R		R		67
*	VALVE CLEARANCE				I		I		I		I		—
	ENGINE OIL				R		R		R		R		62
	ENGINE OIL FILTER				R		R		R		R		63
	RADIATOR COOLANT	NOTE (3)					I		I		R		20
*	COOLING SYSTEM						I		I		I		—
*	SECONDARY AIR SUPPLY SYSTEM						I		I		I		—

ITEM	FREQUENCY	WHICHEVER → COMES FIRST ↓ NOTE	ODOMETER READING [ NOTE (1) ]							Refer to page	
			× 1,000 km	1	6	12	18	24	30		36
			× 1,000 mi	0.6	4	8	12	16	20		24
		MONTH		6	12	18	24	30	36		
FINAL DRIVE OIL					I		I		R	70	
BRAKE FLUID		NOTE (3)			I	I	R	I	I	R	17
BRAKE PAD WEAR					I	I	I	I	I	I	83
BRAKE SYSTEM						I		I		I	17, 83
* BRAKE LIGHT SWITCH						I		I		I	—
* HEADLIGHT AIM						I		I		I	41
CLUTCH SYSTEM						I		I		I	19
CLUTCH FLUID		NOTE (3)			I	I	R	I	I	R	19
SIDE STAND						I		I		I	76
* SUSPENSION						I		I		I	75
* NUTS, BOLTS, FASTENERS						I		I		I	—
** WHEELS/TYRES						I		I		I	—
** STEERING HEAD BEARINGS						I		I		I	—

## TOOL KIT

The tool kit (1) is in the compartment box behind the left side cover (page 39).

Some roadside repairs, minor adjustments and parts replacement can be performed with the tools contained in the kit.

- 10 × 12 mm Open end wrench
- 14 × 17 mm Open end wrench
- 8 mm Open end wrench
- 5 mm Hex wrench
- 6 mm Hex wrench
- Spark plug wrench
- Standard/Phillips screwdriver
- Extension bar
- Screwdriver grip
- Pin spanner
- Pliers
- Tool bag

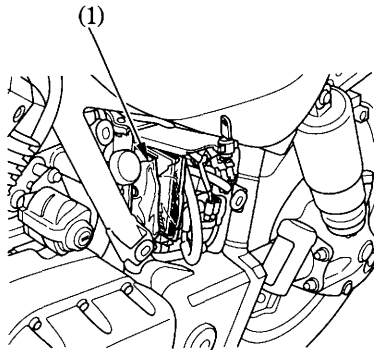

(1) Tool kit

## SERIAL NUMBERS

The frame and engine serial numbers are required when registering your motorcycle. They may also be required by your dealer when ordering replacement parts.

Record the numbers here for your reference.

FRAME NO. \_\_\_\_\_

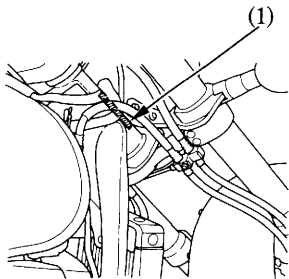

(1) Frame number

The frame number (1) is stamped on the right side of the steering head.

The engine number (2) is stamped on top of the crankcase.

ENGINE NO. \_\_\_\_\_

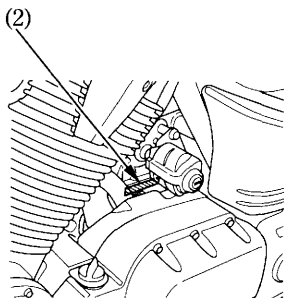

(2) Engine number

## COLOUR LABEL

The colour label (1) is attached to the frame behind the left side cover (page 39 ). It is helpful when ordering replacement parts. Record the colour and code here for your reference.

COLOUR \_\_\_\_\_

CODE \_\_\_\_\_

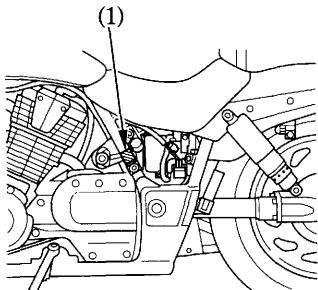

(1) Colour label

## ENGINE OIL

Refer to the Safety Precautions on page 55 .

### Engine Oil

Good engine oil has many desirable qualities. Use only high detergent, quality motor oil certified on the container to meet or exceed requirements for API Service Classification SE, SF or SG.

### Viscosity:

Viscosity grade of engine oil should be based on average atmospheric temperature in your riding area. The following provides a guide to the selection of the proper grade or viscosity of oil to be used at various atmospheric temperatures.

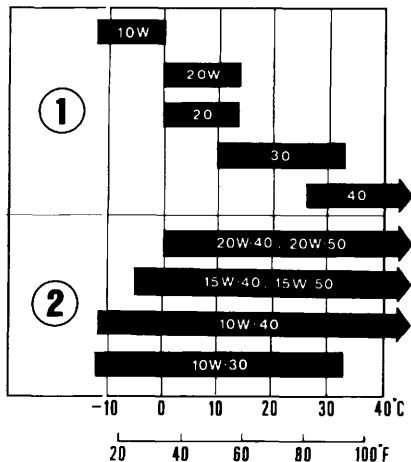

(1) Single grade

(2) Multi grade

## **Engine Oil and Filter**

Engine oil quality is the chief factor affecting engine service life. Change the engine oil as specified in the maintenance schedule (page 57 ).

When running in very dusty conditions, oil changes should be performed more frequently than specified in the maintenance schedule.

Please dispose of used engine oil in a manner that is compatible with the environment. We suggest you take it in a sealed container to your local recycling center or service station for reclamation. Do not throw it in the trash or pour it on the ground or down a drain.

Used engine oil may cause skin cancer if repeatedly left in contact with the skin for prolonged periods. Although this is unlikely unless you handle used oil on a daily basis, it is still advisable to thoroughly wash your hands with soap and water as soon as possible after handling used oil.

Changing the oil filter requires a special oil filter tool and a torque wrench. If you do not have these tools and the necessary skill, we recommend that you have your Honda dealer perform this service.

If a torque wrench is not used for this installation, see your Honda dealer as soon as possible to verify proper assembly.

Change the engine oil with the engine at normal operating temperature and the motorcycle on its center stand to assure complete and rapid draining.

1. To drain the oil, remove the oil filler cap/  
dipstick and crankcase drain plug A (1),  
B (2) and sealing washer A (3), B (4).

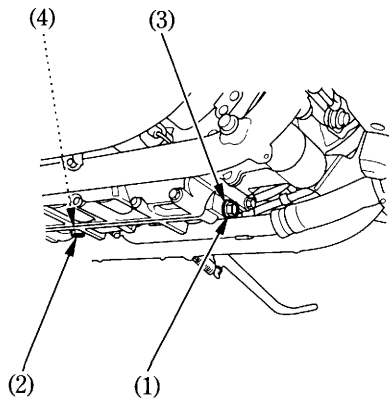

2. Remove the oil filter (5) with a filter  
wrench and let the remaining oil drain out.  
Discard the oil filter.

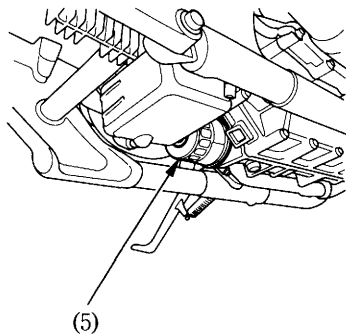

(1) Oil drain plug A  
(2) Oil drain plug B

(3) Sealing washer A  
(4) Sealing washer B

(5) Oil filter

3. Apply a thin coat of engine oil to the new oil filter rubber seal (6).
4. Using a special tool and a torque wrench, install the new oil filter and tighten to a torque of:  
26 N·m (2.7 kgf·m , 20 lbf·ft)

Use only the Honda genuine oil filter or a filter of equivalent quality specified for your model. Using the wrong Honda filter or a non-Honda filter which is not of equivalent quality may cause engine damage.

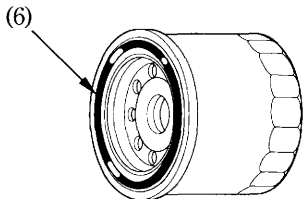

(6) Oil filter rubber seal

5. Check that the sealing washer on the drain plug is in good condition and install the plug. Replace the sealing washer every other time the oil is changed, or each time if necessary.  
Oil Drain Plug Torque:  
30 N·m (3.1 kgf·m , 22 lbf·ft)
6. Fill the crankcase with the recommended grade oil; approximately:  
3.7 ℓ (3.9 US qt , 3.3 Imp qt)
7. Install the oil filler cap/dipstick.
8. Start the engine and let it idle for 2–3 minutes.
9. Several minutes after stopping the engine, check that the oil level is at the upper level mark on the dipstick with the motorcycle upright on firm, level ground. Make sure there are no oil leaks.

## CRANKCASE BREATHER

Refer to the Safety Precautions on page 55.

1. Remove the drain tube (1) drain deposits into a suitable container.
2. Reinstall the drain tube.

Service more frequently when riding in rain or at full throttle.

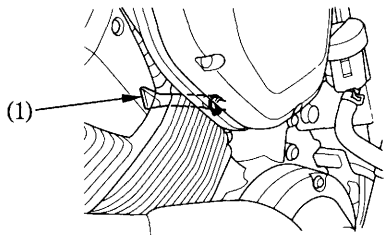

(1) Drain tube

## SPARK PLUGS

Refer to the Safety Precautions on page 55 .

Recommended plugs:

Standard:

IFR6L11 (NGK) or  
VK20PRZ11 (DENSO)

For cold climate: (Below 5°C, 41°F)

IFR5L11 (NGK) or  
VK16PRZ11 (DENSO)

For extended high speed riding:

IFR7L11 (NGK) or  
VK22PRZ11 (DENSO)

### NOTICE

Never use a spark plug with an improper heat range. Severe engine damage could result.

This motorcycle uses the spark plugs that have a iridium coated center electrode. Be sure to observe the following when servicing the spark plugs.

- Do not clean the spark plug. If the electrode is contaminated with accumulated objects or dirt, replace the spark plug with a new one.
- Use only “wire-type feeler gauge” to check the spark plug gap to prevent damaging the iridium coating of the center electrodes. Never use “leaf-type feeler gauge”.
- Do not adjust the spark plug gap. If the gap is out of specification, replace the spark plug with a new one.

1. Remove the plug cover (1) by removing the two screws (2).
2. Clean any dirt from around the spark plug bases.  
Remove the spark plugs using the spark plug wrench furnished in the tool kit.

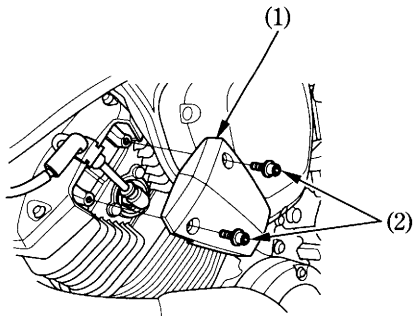

- (1) Plug cover
- (2) Screws

3. Inspect the electrodes and center porcelain for deposits, erosion or carbon fouling. If the erosion or deposit is heavy, replace the plug.
4. Make sure that the 1.4 mm wire-type feeler gauge does not insert between the spark plug gap (3). If the gauge is inserted into the gap, replace the plug with a new one.
5. Make sure the plug washer is in good condition.

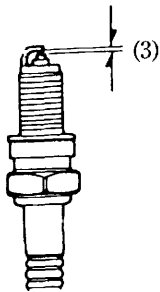

(3) Spark plug gap

6. With the plug washer attached, thread the spark plug in by hand to prevent cross-threading.
7. Tighten a new spark plug 1/2 turn with a spark plug wrench to compress the washer. If you are reusing a plug, it should only take 1/8–1/4 turn after the plug seats.

#### NOTICE

The spark plug must be securely tightened. An improperly tightened plug can become very hot and possibly damage the engine.

8. Reinstall the spark plug caps.
9. Install the remaining parts in the reverse order of removal.

## FINAL DRIVE OIL

Refer to the Safety Precautions on page 55 .

Change the oil as specified in the maintenance schedule.

Change the oil with the final drive at normal operating temperature and the motorcycle upright on level ground to assure complete and rapid draining.

1. To drain the oil, remove the oil filler cap (1) and oil drain plug (2).
2. After the oil has completely drained, check that the sealing washer (3) on the drain plug is in good condition and install the drain plug.

Drain Plug Torque:

20 N·m (2.0 kgf·m , 14 lbf·ft)

3. Place the motorcycle on its side stand, fill the final drive with the recommended grade oil; approximately:

120 cm<sup>3</sup> (4.1 US oz , 4.2 Imp oz)

Make sure the final drive is filled up to the lower edge of the inspection hole (4) with the recommended oil.

4. Install the oil filler cap.

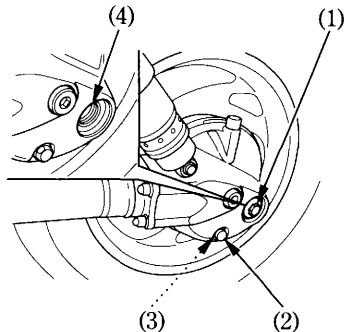

- (1) Oil filler cap  
(2) Oil drain plug

- (3) Sealing washer  
(4) Inspection hole

## THROTTLE OPERATION

Refer to the Safety Precautions on page 55 .

1. Check for smooth rotation of the throttle grip from the fully open to the fully closed position at both full steering positions.
2. Measure the throttle grip free play at the throttle grip flange.  
The standard free play should be approximately:  
2 – 6 mm (0.08 – 0.24 in)

To adjust the free play, loosen the lock nut (1) and turn the adjuster (2).

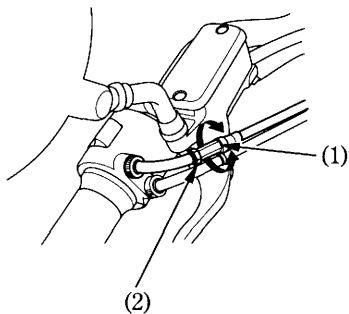

(1) Lock nut

(2) Adjuster

## **IDLE SPEED**

Refer to the Safety Precautions on page 55 .

The engine must be at normal operating temperature for accurate idle speed adjustment. Ten minutes of stop-and-go riding is sufficient.

1. Warm up the engine, and shift to neutral, and place the motorcycle on its side stand.
2. Connect a tachometer to the engine.
3. Adjust idle speed with the throttle stop screw (1).

Idle speed (In neutral):

$800 \pm 100 \text{ min}^{-1} (\text{rpm})$

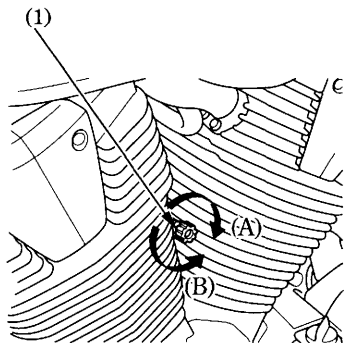

(1) Throttle stop screw

(A) Increase

(B) Decrease

## COOLANT

Refer to the Safety Precautions on page 55 .

### Coolant Replacement

Coolant should be replaced by a Honda dealer, unless the owner has proper tools and service data and is mechanically qualified. Refer to an official Honda Service Manual.

Always add coolant to the reserve tank. Do not attempt to add coolant by removing the radiator cap.

## WARNING

Removing the radiator cap while the engine is hot can cause the coolant to spray out, seriously scalding you.

Always let the engine and radiator cool down before removing the radiator cap.

## AIR CLEANER

Refer to the Safety Precautions on page 55 .

The air cleaner should be serviced at regular intervals (page 52 ). Service more frequently when riding in unusually wet or dusty areas.

1. Remove the five bolts (1 ) and washers (2), and air cleaner housing cover (3).

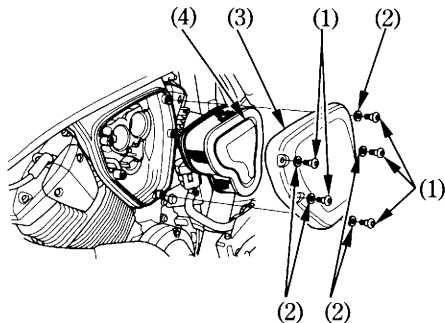

- |             |                               |
|-------------|-------------------------------|
| (1) Bolts   | (3) Air cleaner housing cover |
| (2) Washers | (4) Air cleaner               |

2. Remove and discard the air cleaner (4).

3. Install a new air cleaner.

Use the Honda genuine air cleaner or an equivalent air cleaner specified for your model. Using the wrong Honda air cleaner or a non-Honda air cleaner which is not of equivalent quality may cause premature engine wear or performance problems.

4. Install the removed parts in reverse order of removal.

## **FRONT AND REAR SUSPENSION INSPECTION**

Refer to the Safety Precautions on page 55 .

1. Check the fork assembly by locking the front brake and pumping the fork up and down vigorously. Suspension action should be smooth and there must be no oil leakage.
2. Swingarm bearings should be checked by pushing hard against the side of the rear wheel while the motorcycle is on a support block. Free play indicates worn bearings.
3. Carefully inspect all front and rear suspension fasteners for tightness.

## SIDE STAND

Refer to the Safety Precautions on page 55 .

Perform the following maintenance in accordance with the maintenance schedule.

### Functional Check:

- Check the spring (1) for damage or loss of tension and the side stand assembly for freedom of movement.
- Check the side stand ignition cut-off system:
  1. Sit astride the motorcycle; put the side stand up and the transmission in neutral.
  2. Start the engine and with the clutch lever pulled in, shift the transmission into gear.
  3. Lower the side stand. The engine should stop as you put the side stand down.

If the side stand system does not operate as described, see your Honda dealer for service.

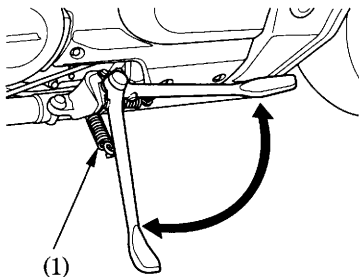

(1) Side stand spring

## WHEEL REMOVAL

Refer to the Safety Precautions on page 55 .

### Front Wheel Removal

1. Raise the front wheel off the ground by using a chain hoist.
2. Remove the right and left caliper assembly (1) from the fork leg by removing the fixing bolts (2).

To avoid damage to the brake hose, support the caliper assembly so that it doesn't hang from the hose. Do not twist the brake hose.

Avoid getting grease, oil, or dirt on the disc or pad surfaces. Any contamination can cause poor brake performance or rapid pad wear after reassembly.

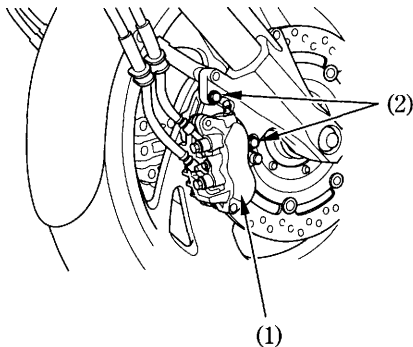

- (1) Brake caliper assembly
- (2) Fixing bolts

Do not depress the brake lever when the caliper assembly is removed. The caliper piston will be forced out of the cylinder with subsequent loss of brake fluid. If this occurs, servicing of the brake system will be necessary. See your Honda dealer for this service.

3. Loosen the right and left axle pinch bolts (3), and remove the axle bolt (4).
4. Remove the front axle (5) and the wheel.

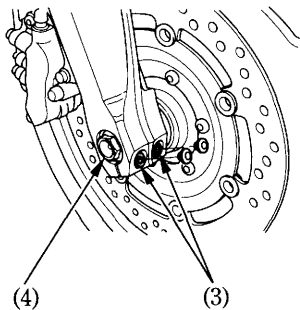

- (3) Axle pinch bolts
- (4) Axle bolt

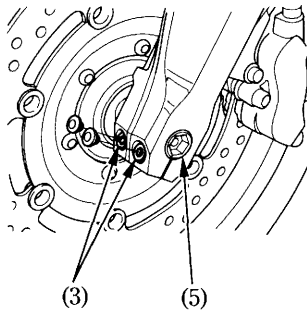

- (5) Front axle

### Installation:

1. Position the front wheel between the fork legs and insert the front axle from the left side, through the left fork leg and wheel hub.

To avoid damaging the brake pads while installing the wheel, carefully fit the brake disc between the pads.

2. Tighten the axle pinch bolts on the left fork leg to the specified torque:

22 N·m (2.2 kgf·m , 16 lbf·ft)

3. Tighten the axle bolt to the specified torque:

90 N·m (9.2 kgf·m , 67 lbf·ft)

4. Install the brake caliper onto the fork leg. To avoid damaging the brake pads, carefully fit both brake discs between the pads.

5. Install the caliper fixing bolts and tighten to the specified torque:

30 N·m (3.1 kgf·m , 22 lbf·ft)

6. Operate the front brake and pump the fork several times. Check for free wheel rotation after the brake is released. Recheck the wheel if the brake drags or the wheel does not rotate freely.

7. Tighten the axle pinch bolts on the right fork leg to specified torque:

22 N·m (2.2 kgf·m , 16 lbf·ft)

8. After installing the wheel, apply the brakes several times, then recheck the both discs for caliper body (not brake pads) to disc clearance. Do not operate the motorcycle without adequate clearance.

- Check for free wheel rotation after the brake lever and brake pedal are released. Recheck the wheel if the brake drags or if the wheel does not rotate freely.
- Verify proper brake operation before riding.
- After installing the wheel, operate the brake lever AND brake pedal several times until you feel pressure. You must restore pressure from BOTH the lever AND the pedal because this motorcycle is equipped with a new braking system.

If the torque wrench was not used for installation, see your Honda dealer as soon as possible to verify proper assembly. Improper assembly may lead to loss of braking capacity.

## Rear Wheel Removal

1. Raise the rear wheel off the ground by using a chain hoist.
2. Remove the axle nut (1) while holding the axle shaft (2) at the end with a wrench.
3. Remove the rear brake bracket bolt (3).
4. Pull out the axle shaft.
5. Remove the rear brake bracket (4).
6. Move the wheel to the left to separate it from the final drive gear case.
7. Remove the rear wheel.

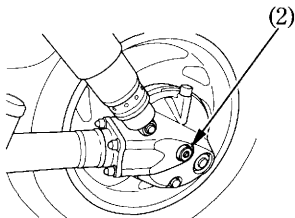

(2) Axle shaft

Support the caliper assembly before removing the rear axle so that the caliper does not hang from the brake hose. Do not twist the brake hose.

Avoid getting grease, oil, or dirt on the disc or pad surfaces. Any contamination can cause poor brake performance or rapid pad wear after reassembly.

Do not depress the brake pedal while the wheel is off the motorcycle. The caliper pistons will be forced out of the cylinders with subsequent loss of brake fluid. If this occurs, servicing of the brake system will be necessary. See your Honda dealer for this service.

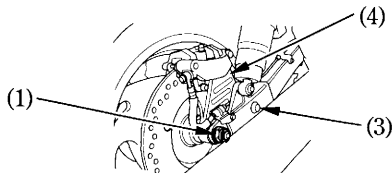

(1) Axle nut  
(3) Bracket bolt

(4) Brake bracket

### Installation Notes:

- To install the rear wheel, reverse the removal procedure.
- Before installing the rear wheel, check that the wheel hub and final drive gear splines are coated with grease.
- Be sure the splines on the wheel hub fit into the final gear case.
- Tighten and torque the nuts and bolts to the specified torque:

Axle nut:

110 N·m (11.2 kgf·m , 81 lbf·ft)

Bracket bolt:

69 N·m (7.0 kgf·m , 51 lbf·ft)

When installing the wheel, carefully fit the brake disc between the brake pads to avoid damaging the pads.

After installing the wheel, apply the brake several times and then check if the wheel rotates freely. Recheck the wheel if the brake drags or if the wheel does not rotate freely.

If a torque wrench was not used for installation, see your Honda dealer as soon as possible to verify proper assembly. Improper assembly may lead to loss of braking capacity.

## **BRAKE PAD WEAR**

Refer to the Safety Precautions on page 55 .

Brake pad wear depends upon the severity of usage, the type of riding, and road conditions. (Generally, the pads will wear faster on wet and dirty roads.)

Inspect the pads at each regular maintenance interval (page 58).

### **Front Brake**

Check the cutout (1) in each pad.

If either pad is worn to the cutout, replace both pads as a set. See your Honda dealer for this service.

### **< FRONT BRAKE >**

Illustration shows right side, left side similar.

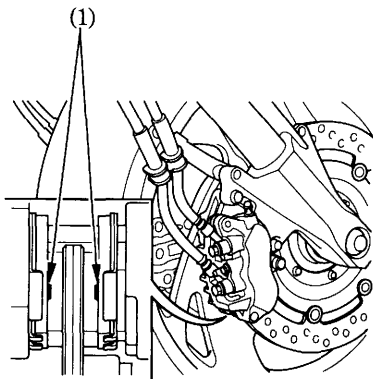

(1) Cutouts

## Rear Brake

Check the cutout (2) in each pad.  
If either pad is worn to the cutout, replace both pads as a set. See your Honda dealer for this service.

### < REAR BRAKE >

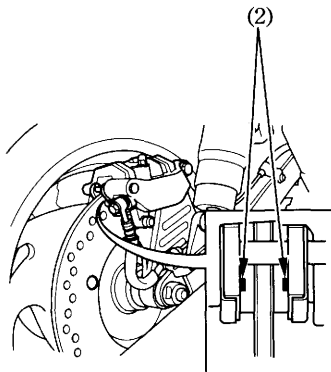

(2) Cutouts

## **BATTERY**

Refer to the Safety Precautions on page 55 .

It is not necessary to check the battery electrolyte level or add distilled water as the battery is a maintenance-free (sealed) type. If your battery seems weak and/or is leaking electrolyte (causing hard starting or other electrical troubles), contact your Honda dealer.

### **NOTICE**

Your battery is a maintenance-free type and can be permanently damaged if the cap strip is removed.

## **WARNING**

The battery gives off explosive hydrogen gas during normal operation.

A spark or flame can cause the battery to explode with enough force to kill or seriously hurt you.

Wear protective clothing and a face shield, or have a skilled mechanic do the battery maintenance.

## Battery Removal

The battery (6) is in the battery box below the seat.

1. Remove the seat (page 40 ).
2. Remove the ECU (1).
3. Remove the battery cover (2) by removing three screws (3).
4. Disconnect the negative (-) terminal lead (4) from the battery first, then disconnect the positive (+) terminal lead (5).
5. Pull out the battery (6) from the battery box.

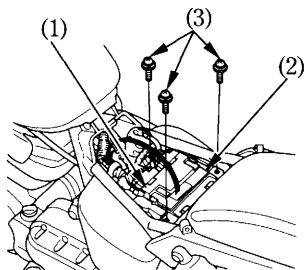

(1) ECU

(3) Screws

(2) Battery cover

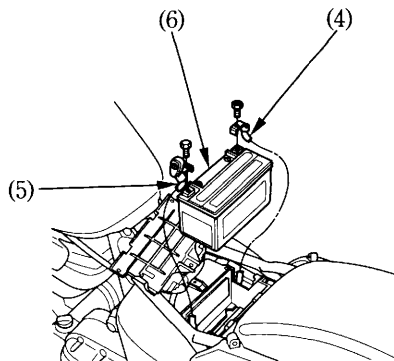

(4) Negative (-) terminal lead

(5) Positive (+) terminal lead

(6) Battery