

 **HONDA**

OWNER'S MANUAL

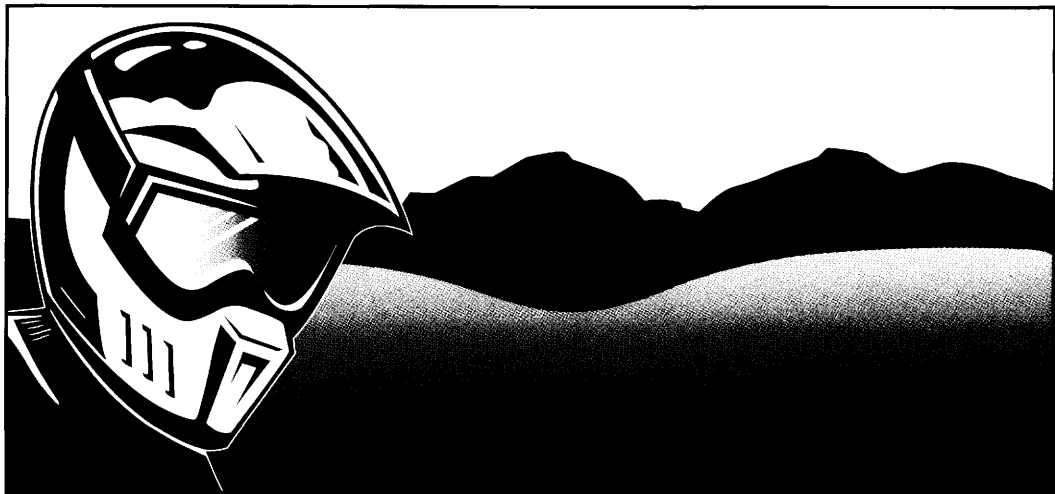

05

X R 6 5 0 L

This manual should be considered a permanent part of the motorcycle and should remain with the motorcycle when it is resold.

This publication includes the latest production information available before printing. Honda Motor Co., Ltd. reserves the right to make changes at any time without notice and without incurring any obligation.

No part of this publication may be reproduced without written permission.

© 2004 Honda Motor Co., Ltd.

**2005
Honda XR650L
OWNER'S MANUAL**

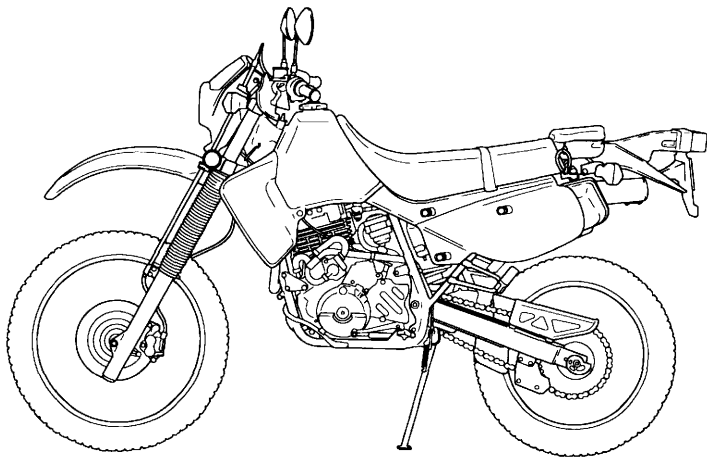

Introduction

Congratulations on choosing your Honda motorcycle.

When you own a Honda, you're part of a worldwide family of satisfied customers — people who appreciate Honda's reputation for building quality into every product.

Before riding, take time to get acquainted with your motorcycle and how it works. To protect your investment, we urge you to take responsibility for keeping your motorcycle well maintained. Scheduled service is a must, of course. But it's just as important to observe the break-in guidelines, and perform all pre-ride and other periodic checks detailed in this manual.

We also recommend that you read this owner's manual before you ride. It's full of facts, instructions, safety information, and helpful tips. To make it easy to use, the manual contains a detailed list of topics at the beginning of each section, and both an in-depth table of contents and an index at the back of the book.

As you read this manual, you will find information that is preceded by a **NOTICE** symbol. This information is intended to help you avoid damage to your Honda, other property, or the environment.

Introduction

Read the Warranties Booklet (page 201) thoroughly so you understand the coverages that protect your new Honda and are aware of your rights and responsibilities.

If you have any questions, or if you ever need special service or repairs, remember that your Honda dealer knows your motorcycle best and is dedicated to your complete satisfaction.

Please report any change of address or ownership to your Honda dealer so we will be able to contact you concerning important production information.

You may also want to visit our website at www.honda.com.

Happy riding!

California Proposition 65 Warning

WARNING: This product contains or emits chemicals known to the State of California to cause cancer and birth defects or other reproductive harm.

A Few Words About Safety

Your safety, and the safety of others, is very important. And operating this motorcycle safely is an important responsibility.

To help you make informed decisions about safety, we have provided operating procedures and other information on labels and in this manual. This information alerts you to potential hazards that could hurt you or others.

Of course, it is not practical or possible to warn you about all hazards associated with operating or maintaining a motorcycle. You must use your own good judgment.

You will find important safety information in a variety of forms, including:

- **Safety Labels** — on the motorcycle.
- **Safety Messages** — preceded by a safety alert symbol  and one of three signal words: **DANGER**, **WARNING**, or **CAUTION**.

These signal words mean:

Safety Messages

A Few Words About Safety

DANGER

You **WILL** be **KILLED** or **SERIOUSLY HURT** if you don't follow instructions.

WARNING

You **CAN** be **KILLED** or **SERIOUSLY HURT** if you don't follow instructions.

CAUTION

You **CAN** be **HURT** if you don't follow instructions.

- **Safety Headings** — such as Important Safety Reminders or Important Safety Precautions.
- **Safety Section** — such as Motorcycle Safety.
- **Instructions** — how to use this motorcycle correctly and safely.

This entire manual is filled with important safety information — please read it carefully.

Contents

These pages give an overview of the contents of your owner's manual. The first page of each section lists the topics covered in that section.

Motorcycle Safety..... 1

Important safety information you should know, plus a look at the safety-related labels on your motorcycle.

Instruments & Controls..... 11

The location and function of indicators and controls on your motorcycle and operating instructions for various controls and features.

Before Riding..... 25

The importance of wearing a helmet and other protective gear, how to make sure you and your motorcycle are ready to ride, and important information about loading.

Basic Operation & Riding..... 39

How to start and stop the engine, shift gears, and brake. Also, riding precautions and important information about riding with a passenger or cargo.

Contents

Servicing Your Honda 55

Why your motorcycle needs regular maintenance, what you need to know before servicing your Honda, an owner maintenance schedule, and instructions for specific maintenance and adjustment items.

Tips..... 147

How to store and transport your motorcycle and how to be an environmentally-responsible rider.

Taking Care of the Unexpected 155

What to do if you have a flat tire, your engine won't start, etc.

Technical Information 177

ID numbers, technical specifications, and other technical facts.

Consumer Information 197

Information on warranties, emission controls, how to get Honda service manuals, and...

“Reporting Safety Defects” 206

Table of Contents 208

Sequential listing of topics in this owner's manual.

Index..... 212

Quick Reference

Handy facts about fuel, engine oil, tire sizes, and air pressures.

Motorcycle Safety

This section presents some of the most important information and recommendations to help you ride your motorcycle safely. Please take a few moments to read these pages. This section also includes information about the location of safety labels on your motorcycle.

Important Safety Information	2
Accessories & Modifications	7
Safety Labels	9

Important Safety Information

Your motorcycle can provide many years of service and pleasure — if you take responsibility for your own safety and understand the challenges you can meet while riding.

There is much that you can do to protect yourself when you ride. You'll find many helpful recommendations throughout this manual. The following are a few that we consider most important.

Always Wear a Helmet

It's a proven fact: helmets significantly reduce the number and severity of head injuries. So always wear an approved motorcycle helmet and make sure your passenger does the same. We also recommend that you wear eye protection, sturdy boots, gloves, and other protective gear (page 26).

Important Safety Information

Take Time to Learn & Practice

Even if you have ridden other motorcycles, take time to become familiar with how this motorcycle works and handles. Practice in a safe area until you build your skills and get accustomed to the motorcycle's size and weight.

Because many accidents involve inexperienced or untrained riders, we urge all riders to take a certified course approved by the Motorcycle Safety Foundation (MSF). See page 29 .

Developing off-road riding skills is a gradual step-by-step process. Start by practicing at low speeds in a safe area and slowly build your skills. See page 29 .

Ask your dealer if there are off-road riding groups in your area where you can learn from experienced riders. Also be sure to read *Tips & Practice Guide for the Off-Highway Motorcyclist* that came with your new motorcycle (USA only).

Important Safety Information

Ride Defensively On-Road

The most frequent motorcycle collision happens when a car turns left in front of a motorcycle. Another common situation is a car moving suddenly into your lane.

Always pay attention to other vehicles around you, and do not assume that other drivers see you. Be prepared to stop quickly or make an evasive maneuver. For other riding tips, see the booklet, *You and Your Motorcycle: Riding Tips and Practice Guide*, which came with your new motorcycle (USA only).

Make Yourself Easy to See On-Road

Some drivers do not see motorcycles because they are not looking for them. To make yourself more visible, wear bright reflective clothing, position yourself so other drivers can see you, signal before turning or changing lanes, and use your horn when it will help others notice you.

Be Alert for Off-Road Hazards

The terrain can present a variety of challenges when you ride off-road. Continually “read” the terrain for unexpected turns, drop-offs, rocks, ruts and other hazards.

Always keep your speed low enough to allow time to see and react to hazards.

Important Safety Information

Ride within Your Limits

Pushing limits is another major cause of motorcycle accidents. Never ride beyond your personal abilities or faster than conditions warrant. Remember that alcohol, drugs, fatigue, and inattention can significantly reduce your ability to make good judgments and ride safely.

Don't Drink and Ride

Alcohol and riding don't mix. Even one drink can reduce your ability to respond to changing conditions, and your reaction time gets worse with every additional drink. So don't drink and ride, and don't let your friends drink and ride either.

Important Safety Information

Keep Your Honda in Safe Condition

It's important to keep your motorcycle properly maintained and in safe riding condition. Having a breakdown can be difficult, especially if you are stranded off-road far from your base. To help avoid problems, inspect your motorcycle before every ride and perform all recommended maintenance. Never exceed load limits (page 36), and do not modify your motorcycle (page 8) or install accessories that would make your motorcycle unsafe (page 7).

Accessories & Modifications

Modifying your motorcycle or using non-Honda accessories can make your motorcycle unsafe. Before you consider making any modifications or adding an accessory, be sure to read the following information.

⚠ WARNING

Improper accessories or modifications can cause a crash in which you can be seriously hurt or killed.

Follow all instructions in this owner's manual regarding accessories and modifications.

Accessories

We strongly recommend that you use only genuine Honda accessories that have been specifically designed and tested for your motorcycle. Because Honda cannot test all other accessories, you must be personally responsible for proper selection, installation, and use of non-Honda accessories.

Check with your Honda dealer for assistance and always follow these guidelines:

- Make sure the accessory does not obscure any lights, reduce ground clearance and lean angle, limit suspension travel or steering travel, alter your riding position, or interfere with operating any controls. (cont'd)

Accessories & Modifications

- Do not install any fairing or windshield unless it was designed and tested by Honda for your motorcycle. Some fairings or windshields, even smaller ones, can cause unstable handling of your motorcycle. This is especially true if the fairing or windshield is poorly designed or improperly mounted.
- Do not add any electrical equipment that will exceed the motorcycle's electrical system capacity (page 185). A blown fuse can cause a loss of lights or engine power (page 171).
- Do not pull a trailer or sidecar with your motorcycle. This motorcycle was not designed for these attachments, and their use can seriously impair your motorcycle's handling.

Modifications

We strongly advise you not to remove any original equipment or modify your motorcycle in any way that would change its design or operation. Such changes could seriously impair your motorcycle's handling, stability, and braking, making it unsafe to ride.

We also advise you not to make any modifications or remove any equipment (such as the USDA qualified spark arrester or emission control system components) that would make your motorcycle illegal in your area.

Safety Labels

Safety labels on your motorcycle either warn you of potential hazards that could cause serious injury or they provide important safety information. Read these labels carefully and don't remove them.

If a label comes off or becomes hard to read, contact your Honda dealer for a replacement.

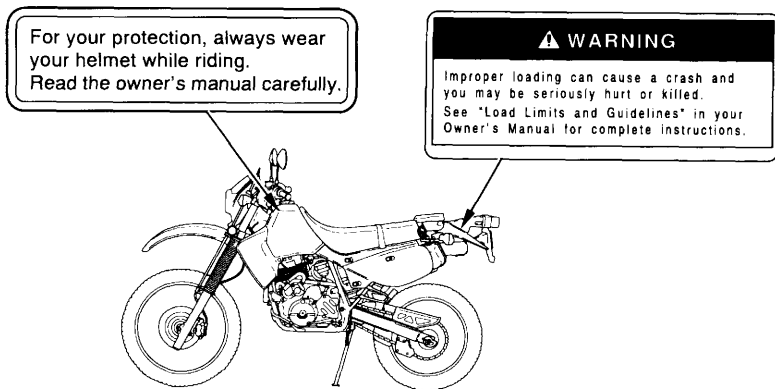

(cont'd)

Safety Labels

TIRE INFORMATION		
Cold tire pressures : [Up to maximum weight capacity]	Front	150kPa 1.50kgf/cm ² 22psi.
	Rear	150kPa 1.50kgf/cm ² 22psi.
[Up to 90kg (200lbs) load]	Front	150kPa 1.50kgf/cm ² 22psi.
	Rear	150kPa 1.50kgf/cm ² 22psi.
Maximum weight capacity : 149kg(328lbs)		
Tire size : Front 3.00-21 51S		
Rear 4.60-18 63S		
Tire brand	Front	Rear
DUNLOP	K850	K850
BRIDGESTONE	TW-301	TW52
Min. recommend tire center tread depth.		
	Front 3.0mm (0.12in.)	Rear 3.0mm (0.12in.)
<i>Read owner's manual.</i>		

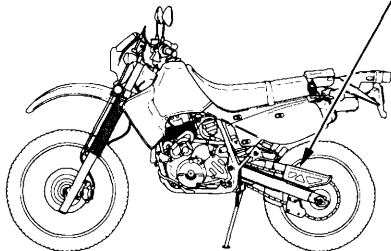

Instruments & Controls

This section shows the location of all gauges, indicators, and controls you would normally use before or while riding your motorcycle.

The items listed on this page are described in this section. Instructions for other components are presented in other sections of this manual where they will be most useful.

Component Locations	12
Indicators	15
Controls & Features	
Fuel Valve.....	19
Choke Lever	20
Ignition Switch	21
Start Button.....	22
Engine Stop Switch	22
Headlight Dimmer Switch	23
Turn Signal Switch.....	23
Horn Button	24
Tripmeter Reset Knob	24

Component Locations

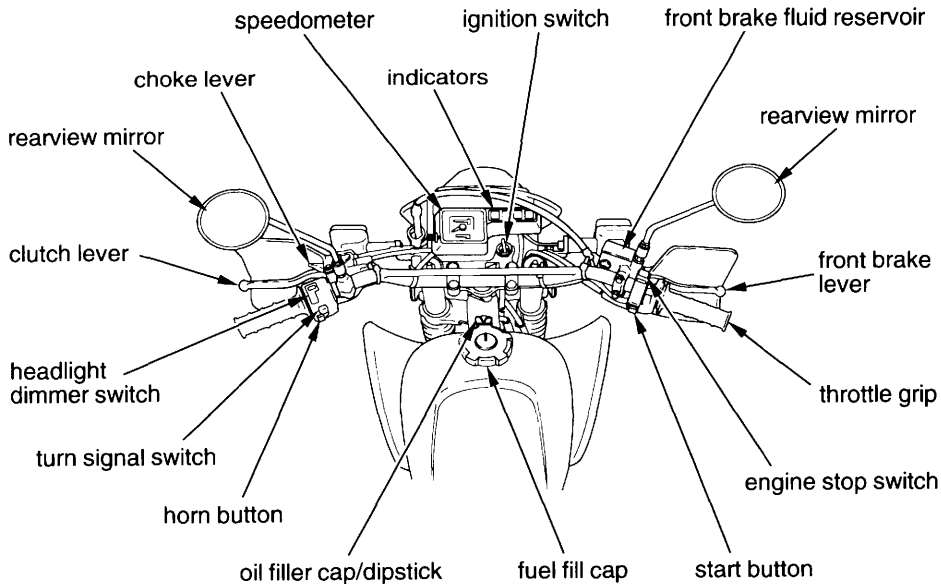

Component Locations

passenger footpeg

rear brake fluid reservoir

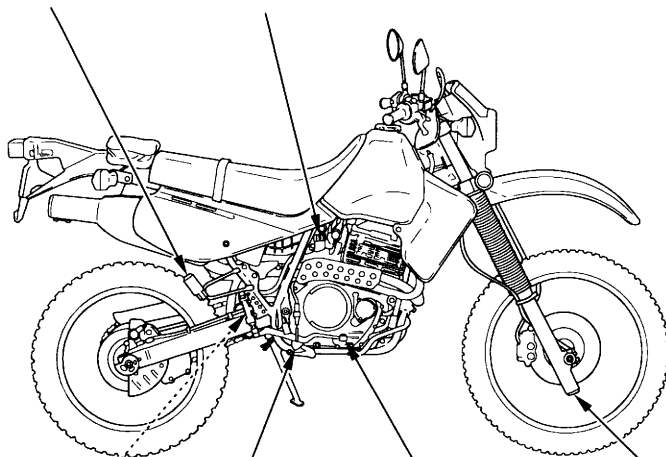

rear rebound damping
adjuster

footpeg

rear brake pedal

front compression
damping adjuster

(cont'd)

Component Locations

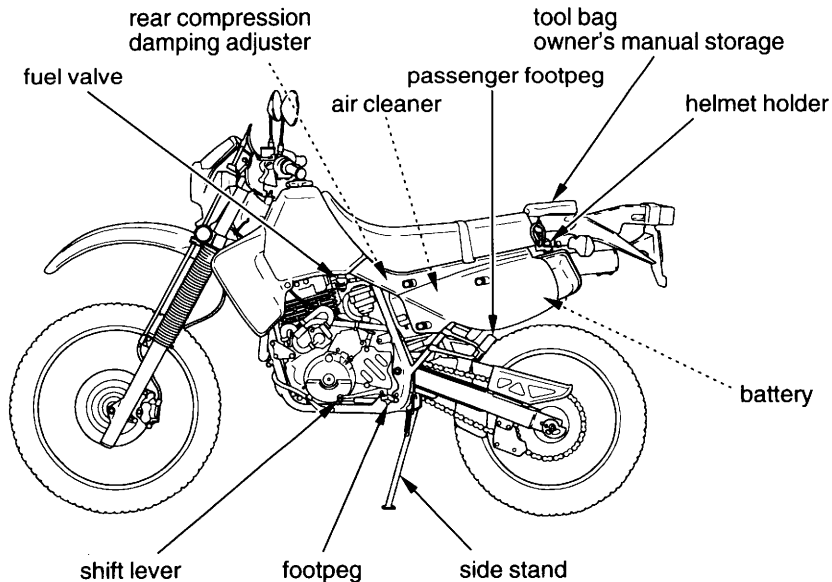

Indicators

The indicators on your motorcycle keep you informed, alert you to possible problems, and make your riding safer and more enjoyable. Refer to the indicators frequently. Their functions are described on the following pages.

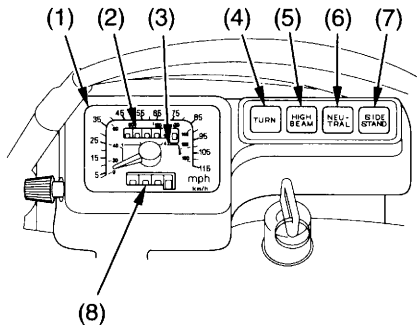

- (1) speedometer
- (2) odometer
- (3) gear range indicator
- (4) turn signal indicator
- (5) high beam indicator
- (6) neutral indicator
- (7) side stand indicator
- (8) tripmeter

USA: Odometer & tripmeter read in miles.

Canada: Odometer & tripmeter read in kilometers.

(cont'd)

Indicators

Lamp Check

When applicable, the high beam, neutral, and side stand indicators come on when you turn the ignition switch ON and remain on until you select the low beam, shift out of neutral, or raise the side stand.

If one of these indicators does not come on when it should, have your Honda dealer check for burned-out bulbs or other problems.

Indicators

1	speedometer	Shows riding speed in miles per hour.
2	odometer	Shows the total miles ridden.
3	gear range indicator	Shows proper speed range for each gear.
4	turn signal indicator (amber)	Flashes when either turn signal operates.

(cont'd)

Indicators

5	high beam indicator (blue)	Lights when the headlight is on high beam.
6	neutral indicator (green)	Lights when the transmission is in neutral.
7	side stand indicator (amber)	Lights when the side stand is put down — to indicate that the side stand ignition cut-off system (page 41) is activated.
8	tripmeter	Shows the number of miles ridden since you last reset the meter. To zero (0) the tripmeter, turn the tripmeter reset knob.

Fuel Valve

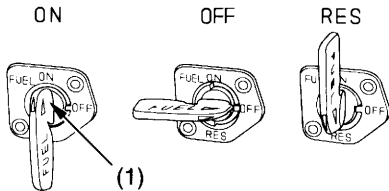

(1) fuel valve

The manual fuel valve is located on the left side under the fuel tank.

The three-way fuel valve is used to control the flow of fuel from the fuel tank to the carburetors.

ON — normal position for riding.

OFF — for parking, storing, or transportation.

RES — for extra fuel to get to a gas station for refueling.

For complete information about fueling your motorcycle, see page 80 .

Controls & Features

Choke Lever



LEFT FRONT

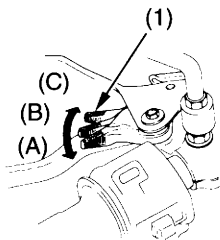

- (1) choke lever (A) fully on
 (B) halfway position
 (C) fully off

The choke lever may be used when starting the engine. See page 42 .

Ignition Switch

The ignition switch is used for starting and stopping the engine (page 41) and to lock the steering for theft prevention (page 50). Insert the key and turn it to the right for the ON position. Push down on the key and turn it to the left to the LOCK (steering lock) position.

Key Position	Function
ON	Electrical circuits on.
OFF	No electrical circuits function.
LOCK (steering lock)	No electrical circuits function. Locks the steering head.

FRONT

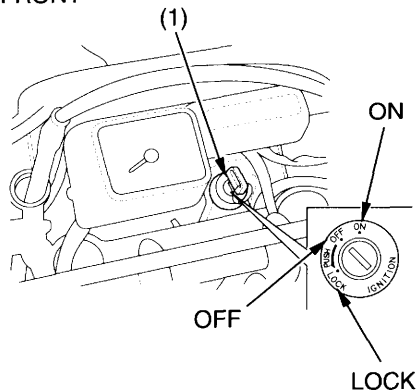

(1) ignition switch

Controls & Features

Start Button

The start button (1) is used for starting the engine. Pushing the button in starts the engine. See *Starting Procedure*, page 42.

When the start button is pushed, the starter motor will crank the engine; the headlight will automatically go out, but the taillight will stay on.

Engine Stop Switch

RIGHT HANDLEBAR (2)

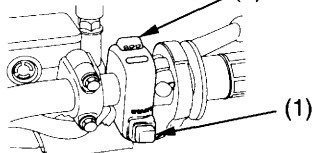

(1) start button

(2) engine stop switch

The engine stop switch (2) is used to stop the engine in an emergency. To operate, push the switch to the OFF position. The switch must be in the RUN position to start the engine, and it should normally remain in the RUN position even when the engine is OFF.

If your motorcycle is stopped with the ignition switch ON and the engine stop switch OFF, the headlight and taillight will remain on, resulting in battery discharge.

Headlight Dimmer Switch

The headlight dimmer switch (1) is used to change between the high and low beams of the headlight. To operate, turn the switch to HI for high beam, LO for low beam.

Turn Signal Switch

The turn signal switch (2) is used to signal a turn or a lane change. To operate, move the switch all the way in the proper direction and release it. The appropriate turn signal lights will start blinking. To cancel the light, push the switch in.

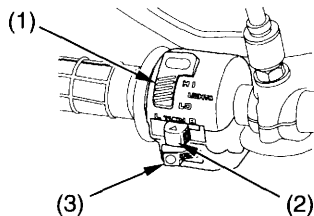

- (1) headlight dimmer switch
- (2) turn signal switch
- (3) horn button

Controls & Features

Horn Button

The horn is used to alert other motorists. To operate, push the horn button (3).

Tripmeter Reset Knob

The reset knob (4) is used to reset the tripmeter to zero (0) by turning the knob in the direction shown.

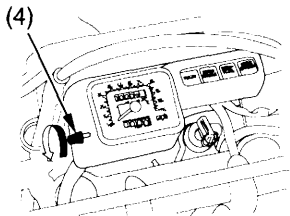

(4) tripmeter reset knob

Before Riding

Before each ride, you need to make sure you and your Honda are both ready to ride. To help get you prepared, this section discusses how to evaluate your riding readiness, what items you should check on your motorcycle, and adjustments to make for your comfort, convenience, or safety. This section also includes important information about loading.

For information about adjusting the suspension on your Honda, see page 107.

Are You Ready to Ride ?	26
Protective Apparel.....	26
Rider Training	29
Is Your Motorcycle Ready to Ride ?	30
Pre-ride Inspection	31
Load Limits & Guidelines.....	34
Loading.....	35
Load Limits	36
Loading Guidelines	36

Are You Ready to Ride?

Before you ride your motorcycle for the first time, we urge you to:

- Read this owner's manual.
- Make sure you understand all the safety messages.
- Know how to operate all the controls.

Before each ride, be sure:

- You feel well and are in good physical and mental condition.
- You are wearing an approved motorcycle helmet (with chin strap tightened securely), eye protection, and other protective clothing.
- You don't have any alcohol or drugs in your system.

Make sure your passenger is ready to ride, too, and is wearing proper gear including a helmet.

If you must carry an extra helmet while riding, use a commercially-available elastic cord, strap, or net to secure the helmet to the seat.

Protective Apparel

For your safety, we strongly recommend that you always wear an approved motorcycle helmet, eye protection, boots, gloves, long pants, and a long-sleeved shirt or jacket whenever you ride. Although complete protection is not possible, wearing proper gear can reduce the chance of injury when you ride. Following are suggestions to help you choose the proper gear.

Are You Ready to Ride?

Helmets and Eye Protection

Your helmet is your most important piece of riding gear because it offers the best protection against head injuries. A helmet should fit your head comfortably and securely. A bright-colored helmet and reflective strips can make you more noticeable in traffic.

An open-face helmet offers some protection, but a full-face helmet offers more. Regardless of the style, look for a DOT (Department of Transportation) sticker in any helmet you buy (USA only). Always wear a face shield or goggles to protect your eyes and help your vision.

▲ WARNING

Not wearing a helmet increases the chance of serious injury or death in a crash.

Be sure you and your passenger always wear a helmet, eye protection, and other protective apparel when you ride.

(cont'd)

Are You Ready to Ride?

Additional On-Road Gear

In addition to a helmet and eye protection, we also recommend:

- Sturdy boots with non-slip soles to help protect your feet and ankles.
- Leather gloves to help protect your hands.
- A motorcycle riding suit or jacket for comfort as well as protection.

Bright-colored and reflective clothing can help make you more noticeable in traffic. Avoid loose clothes that could get caught on any part of your motorcycle.

Additional Off-Road Gear

On-road apparel may also be suitable for casual off-road riding. But if you plan on any serious off-road riding you will need more serious off-road gear. In addition to your helmet and eye protection, we recommend off-road motorcycle boots and gloves, riding pants with knee and hip pads, a jersey with elbow pads, and a chest/shoulder protector.

Are You Ready to Ride?

Rider Training

Developing your riding skills is an on-going process. Even if you have ridden other motorcycles, take time to become familiar with how this motorcycle works and handles. Practice riding the motorcycle in a safe area to build your skills. Do not ride in traffic until you get accustomed to the motorcycle's controls, and feel comfortable with its size and weight.

We urge all riders to take a certified course approved by the Motorcycle Safety Foundation (MSF). New riders should start with the basic course, and even experienced riders will find the advanced course beneficial. For information about the MSF training course nearest you, call the national toll-free number: (800) 446-9227.

Other riding tips can be found in the *Riding Tips* booklet that came with your motorcycle (USA only).

Is Your Motorcycle Ready to Ride?

For your safety, it is very important to inspect your motorcycle before each ride and make sure any problem you find is corrected.

If you plan to ride off-road, a pre-ride inspection is a must, because off-road riding can be tough on a motorcycle and you don't want to have a breakdown far from help.

WARNING

Improperly maintaining this motorcycle or failing to correct a problem before riding can cause a crash in which you can be seriously hurt or killed.

Always perform a pre-ride inspection before every ride and correct any problems.

Is Your Motorcycle Ready to Ride?

Pre-ride Inspection

Before riding on-road, or returning to pavement after riding off-road, take a few moments to walk around your motorcycle and look for any loose parts or anything that appears unusual. Also check the following.

- Tires & Wheels* Look at the tires. If a tire appears low, use an air pressure gauge to check its pressure. Also look for signs of excessive wear (page 121) or damage to the tires, rims and spokes.
- Leaks* Look for signs of leaking fluids under the motorcycle.

Throttle Rotate the throttle to check it moves smoothly without binding.

Brakes Pull the brake lever and press on the brake pedal to check that they operate normally.

Lights Make sure the brake light, taillight, indicators and other lights are working properly.

When riding at high or continuous speed on the highway, check the following frequently:

Engine Oil Check the level and add oil if needed (page 88).

(cont'd)

Is Your Motorcycle Ready to Ride?

Before riding off-road, check all of the preceding plus the following:

- Spokes & Rims* Make sure that spokes are tight. Check the rims for any damage.
- Engine Oil* Check the level and add oil if needed (page 88).
- Fuel Level* Check the fuel level and add as much fuel as needed. Be sure the fuel fill cap is securely fastened.
- Drive Chain* Check the condition of the chain. Adjust slack and lubricate as needed (page 128).

Clutch Check for smooth operation and adjust if needed.

Cables Check for loose cables and other parts, and anything that appears abnormal.

Nuts & Bolts Use a wrench to check the tightness of all accessible nuts, bolts and fasteners.

Is Your Motorcycle Ready to Ride?

If you haven't ridden the motorcycle in over a week, you should also check other items, such as the oil level and other fluids.

See *Periodic Maintenance* (page 62).

Periodic maintenance should also be done at least once a month, no matter how often you ride.

Remember, be sure to take care of any problem you find, or have your Honda dealer correct it before you ride.

Load Limits & Guidelines

When you ride on pavement or hard smooth dirt roads, your motorcycle can carry you and one passenger. When you carry a passenger, you may feel some difference during acceleration and braking. But so long as you keep your motorcycle well-maintained, with good tires and brakes, you can safely carry loads within the given limits and guidelines.

When you ride off-road on rough terrain, we strongly recommend that you do not ride with a passenger or carry cargo. A passenger or cargo could interfere with your ability to move around to maintain your balance and control of the motorcycle.

On road or off, exceeding the weight limit or carrying an unbalanced load can seriously impair your motorcycle's handling, braking, and stability. Non-Honda accessories, improper modifications, and poor maintenance can also reduce your safety margin.

Load Limits & Guidelines

Loading

How much weight you put on your motorcycle, and how you load it, are important to your safety. Anytime you ride with a passenger or cargo, you should be aware of the following information.

⚠ WARNING

Overloading or improper loading can cause a crash and you can be seriously hurt or killed.

Follow all load limits and other loading guidelines in this manual.

Load Limits & Guidelines

Load Limits

Following are the load limits for your motorcycle:

maximum weight capacity:

328 lbs (149 kg)

includes the weight of the rider, passenger, all cargo, and all accessories.

maximum cargo weight:

6 lbs (3 kg)

The weight of added accessories will reduce the maximum cargo weight you can carry.

Loading Guidelines

Improperly loading your motorcycle can affect its stability and handling. Even if your motorcycle is properly loaded, you should ride at reduced speeds whenever you carry cargo.

Load Limits & Guidelines

Follow these guidelines whenever you carry a passenger or cargo:

- Check that both tires are properly inflated (page 119).
- If you change your normal load, you may need to adjust the front suspension (page 108) and the rear suspension (page 111).
- To prevent loose items from creating a hazard, make sure that all cargo is tied down securely before you ride.
- Place cargo weight as low and close to the center of your motorcycle as possible.
- Balance cargo weight evenly on both sides.
- Do not attach large or heavy items (such as a sleeping bag or tent) to the handlebar, forks, or fender.

Also follow these guidelines when you ride off-road on rough terrain:

- Do not carry a passenger.
- Keep cargo small and light weight (6 lbs; 3kg or less). Make sure it cannot easily be caught on brush or other objects, and that it does not interfere with your ability to shift position to maintain balance and stability.

Basic Operation & Riding

This section gives basic riding instructions, including how to start and stop your engine, and how to use the throttle, clutch, and brakes. It also provides important information on riding with a passenger or cargo.

To protect your new engine and enjoy optimum performance and service life, refer to Break-in Guidelines (page 188).

For information about carburetor adjustment for riding at high altitude, see page 189.

Safe Riding Precautions	40
Starting & Stopping the Engine	41
Preparation.....	41
Starting Procedure	42
Flooded Engine.....	44
How to Stop the Engine	45
Shifting Gears.....	46
Braking	48
Parking	50
Riding with a Passenger or Cargo.....	53

Safe Riding Precautions

Before riding your motorcycle for the first time, please review the *Motorcycle Safety* section beginning on page 1, and the *Before Riding* section beginning on page 25 .

Even if you have ridden other motorcycles, take time to become familiar with how this motorcycle works and handles. Practice in a safe area until you build your skills and get accustomed to the motorcycle's size and weight.

Starting & Stopping the Engine

Always follow the proper starting procedure described below.

For your safety, avoid starting or operating the engine in an enclosed area such as a garage. Your motorcycle's exhaust contains poisonous carbon monoxide gas which can collect rapidly in an enclosed area and cause illness or death.

Your motorcycle can be started with the transmission in gear by pulling in the clutch lever before operating the starter.

Your motorcycle is equipped with a side stand ignition cut-off system. If the side stand is down—the engine cannot be started unless the transmission is in neutral. If the side stand is up—the engine can be started in neutral, or in gear with the

clutch lever pulled in. After starting with the side stand down, the engine will stop if the transmission is put in gear before raising the side stand.

Preparation

Before starting, insert the key, turn the ignition switch ON, and confirm the following:

- The transmission is in NEUTRAL (neutral indicator light ON).
- The engine stop switch is set to RUN.
- The fuel valve is ON.

Starting & Stopping the Engine

Starting Procedure

To restart a warm engine, follow the procedure for *High Air Temperature*.

Normal Air Temperature

10° – 35°C (50° – 95°F)

LEFT HANDLEBAR

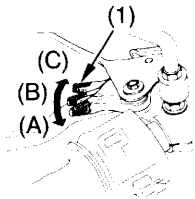

- (1) choke lever (A) fully ON
 (B) halfway position
 (C) fully OFF

1. Pull the choke lever back all the way to fully ON (A), if the engine is cold.
2. With the throttle fully closed, operate the electric starter.

Do not open the throttle when starting the engine with the choke on. This will lean the mixture, resulting in hard starting.

3. Immediately after the engine starts, push the choke lever forward to the halfway position (B).
4. About a half minute after the engine starts, push the choke lever (1) forward all the way to fully OFF (C).
5. If idling is unstable, open the throttle slightly.

Starting & Stopping the Engine

High Air Temperature

35°C (95°F) or above

1. Do not use the choke.
2. With the throttle slightly open (less than 1/8), operate the electric starter.

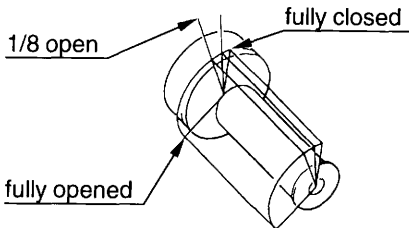

Low Air Temperature

10°C (50°F) or below

1. Follow steps 1-2 under *Normal Air Temperature*.
2. Warm up the engine by opening and closing the throttle slightly.

3. Continue warming up the engine until it runs smoothly and responds to the throttle when the choke lever is at fully OFF (C).

NOTICE

Extended use of the choke may impair piston and cylinder wall lubrication and damage the engine.

Snapping the throttle or fast idling for more than about 5 minutes at normal air temperature may cause exhaust pipe discoloration.

Starting & Stopping the Engine

Flooded Engine

If the engine fails to start after repeated attempts, it may be flooded with excess fuel. To clear a flooded engine:

1. Press the engine stop switch to OFF.
2. Push the choke lever forward all the way to fully OFF.
3. Open the throttle fully.
4. Press the start button for 5 seconds.
5. Wait 10 seconds, then press the engine stop switch to RUN.

Follow the *High Air Temperature* starting procedure:

6. Do not use the choke.
7. With the throttle slightly open (less than

1/8), operate the electric starter.

If the engine still won't start, refer to *If Your Engine Quits or Won't Start*, page 157.

Starting & Stopping the Engine

How to Stop the Engine

Normal Engine Stop

To stop the engine, shift into neutral and turn the ignition switch OFF.

The engine stop switch should normally remain in the RUN position even when the engine is OFF.

If your motorcycle is stopped with the engine stop switch OFF and the ignition switch ON, the headlight and taillight will remain on, resulting in battery discharge.

Emergency Engine Stop

To stop the engine in an emergency, use the engine stop switch. To operate, press the switch to the OFF position.

Shifting Gears

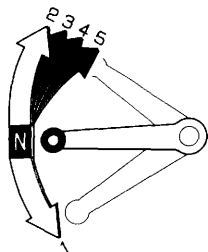

shifting pattern

Your motorcycle has five forward gears in a one-down, four-up shift pattern which is coordinated with a cable-operated clutch system.

Learning when to shift gears comes with experience. Keep the following tips in mind:

- As a general rule, shift while moving in a straight line.

- Close the throttle and pull the clutch lever in completely before shifting. Improper shifting may damage the engine, transmission, and drive train.
- Learn to recognize the engagement point as you release the clutch lever. It is at this point the transmission of power to the rear wheel resumes.
- Upshift to a higher gear or reduce throttle before engine rpm (speed) gets too high. Learn the relationship between engine sound and the normal shifting points.
- Downshift to a lower gear before you feel the engine laboring (lugging) at low rpm.

- Avoid downshifting to help slow your motorcycle when engine rpm is high. Downshifting when engine speed is near its allowable maximum may over-rev the engine and cause possible damage.
- To prevent transmission damage, do not coast or tow the motorcycle for long distances with the engine off.

Recommended Shift Points

Ride in the highest gear that lets the engine run and accelerate smoothly. This will give you good fuel economy and effective emissions control. When changing gears under normal conditions, use these recommended shift points:

Shifting Up:

From 1st to 2nd:	12 mph (20 km/h)
From 2nd to 3rd:	19 mph (30 km/h)
From 3rd to 4th:	25 mph (40 km/h)
From 4th to 5th:	31 mph (50 km/h)

Shifting Down:

From 5th to 4th:	22 mph (35 km/h)
From 4th to 3rd:	16 mph (25 km/h)

Pull the clutch lever in when speed drops below 9 mph (15 km/h), when engine roughness is evident, or when engine stalling is imminent; and shift down to 1st gear for acceleration.

Braking

Your motorcycle is equipped with disc braking systems which are hydraulically activated. Depressing the brake pedal applies the rear disc brake. Operating the brake lever applies the front disc brake.

As a general rule, the front braking system provides about 70 percent of total stopping power.

For full braking effectiveness, use both the pedal and lever simultaneously. Using both braking systems will stop your motorcycle faster with greater stability.

To slow or stop, apply the brake lever and brake pedal smoothly, while downshifting to match your speed.

Gradually increase braking as you feel the brakes slowing your speed. The increase in engine compression from downshifting will help slow your motorcycle.

To prevent stalling the engine, pull the clutch lever in before coming to a complete stop. For support, put your left foot down first, then your right foot when you are through using the brake pedal.

Applying the brakes too hard may cause the wheels to lock and slide, reducing control of your motorcycle. If this happens, release the brake controls, steer straight ahead until you regain control, then reapply the brakes more gently.

When possible, reduce your speed or complete braking before entering a turn. Avoid braking or closing the throttle quickly while turning. Either action may cause one or both wheels to slip and reduce your control of your motorcycle.

Your ability to brake in a turn and to brake hard in an emergency situation are important riding skills. We suggest attending a Motorcycle Safety Foundation experienced rider training course (page 29) to retain these skills.

When riding in wet or rainy conditions, or on loose surfaces, the ability to maneuver and stop will be reduced. All of your actions should be smooth under these conditions. Rapid acceleration, braking or turning may cause loss of control. For

your safety, exercise extreme caution when braking, accelerating or turning.

When descending a long, steep grade, use engine compression braking by downshifting, with intermittent use of both brakes. Continuous brake application can overheat the brakes and reduce their effectiveness.

Riding with your foot resting on the brake pedal or your hand on the brake lever may actuate the brakelight, giving a false indication to other drivers. It may also overheat the brakes, reducing effectiveness.

Parking

1. Look for a level parking area. If you can't park on a paved surface, make sure the ground surface is firm, especially under the side stand. If you must park on a hill, leave the transmission in gear and position the rear tire against the curb at a 45 degree angle.
2. Use the side stand to support the motorcycle while parked.
 - To lower the side stand, use your foot to guide it down. Remember that lowering the side stand with the transmission in gear will stop the engine, even if the clutch lever is pulled in. That is a function of the side stand ignition cut-off system.
 - Check that the side stand is down all the way. The side stand indicator only indicates that the side stand

ignition cut-off system (page 41) is activated.

- If you have to park on a soft surface, insert something solid under the side stand for support.
3. Use the steering lock, which locks the handlebar in place. Turn the handlebar all the way to the left or right. Push in on the ignition key and turn it to LOCK. Remove the key.

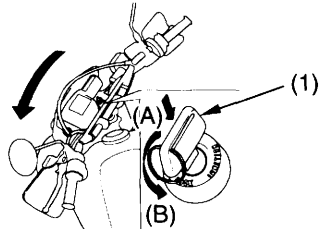

(1) ignition key

(A) push in

(B) turn to LOCK

4. Use the helmet holder (2) to secure your helmet with your motorcycle:
- Insert the ignition key (1) and turn it counterclockwise to unlock the holder.
 - Hang your helmet on the holder pin (3).
 - Push in on the holder pin. Remove the key.

LEFT REAR

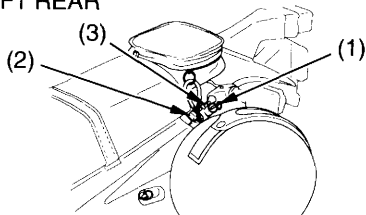

(1) ignition key
(2) helmet holder

(3) holder pin

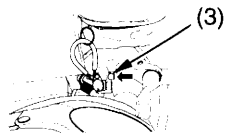

(3) holder pin

⚠ WARNING

Riding with a helmet attached to the holder can interfere with the rear wheel or suspension and could cause a crash in which you can be seriously hurt or killed.

Use the helmet holder only while parked. Do not ride with a helmet secured by the holder.

5. Turn the fuel valve OFF.

Parking

Theft-Prevention Tips

- Park your motorcycle in a locked garage whenever possible. If a garage isn't available, park in a concealed area or in a well-lit area with enough pedestrian traffic to discourage a thief.
 - Always take the ignition key with you.
 - Always use the steering lock (page 50), even if you're parking for just a minute or two. A thief can easily push an unlocked motorcycle to a waiting truck.
 - In addition to the steering lock, use a good quality anti-theft device made specifically to lock a motorcycle to a secure object.
- If you decide to use an anti-theft device, select one of good quality and be sure to follow the manufacturer's instructions.
 - Keep your owner's manual, current registration, and insurance information with your motorcycle. This will make it easier for the authorities to find you if your motorcycle is stolen and recovered.

Riding with a Passenger or Cargo

When you ride on pavement or hard smooth dirt roads, your motorcycle can carry you and one passenger. When you carry a passenger, you may feel some difference during acceleration and braking. But so long as you keep your motorcycle well-maintained, with good tires and brakes, you can safely carry loads within the given limits and guidelines (see page 36).

However, when you ride off-road on rough terrain, we strongly recommend that you do not ride with a passenger or carry cargo. A passenger or cargo could interfere with your ability to move around to maintain your balance and control of the motorcycle.

Also consider adjusting the suspension (page 107) for the extra load.

Be aware that carrying a passenger or heavy cargo can affect acceleration, braking, and handling.

Before riding with a passenger, make sure your passenger is wearing the proper protective apparel (page 26).

Tell your passenger to hold the seat strap or your waist, lean with you in the turns, and keep their feet on the passenger footpegs at all times, even when the motorcycle is stopped at a traffic light.

To help keep your motorcycle in good shape, this section includes a Maintenance Schedule for required service, a list of periodic checks you should perform at least once a month, and step-by-step instructions for specific maintenance tasks. You'll also find important safety precautions, information on fuels and oils, and tips for keeping your Honda looking great.

For information about the exhaust emission and noise emission requirements of the U.S. Environmental Protection Agency (EPA) and the California Air Resources Board (CARB), see page 190 .

For information about replacing fuses, see page 171 .

USA only

Maintenance, replacement or repair of the emission control devices and systems may be performed by any motorcycle repair establishment or individual using parts that are "certified" to EPA standards.

Before You Service Your Honda

The Importance of Maintenance	58
Maintenance Safety	59
Important Safety Precautions.....	60
Periodic Maintenance	62
Maintenance Schedule	64
Maintenance Record.....	69

(cont'd)

Servicing Your Honda

Service Preparations

Component Locations	71
Tool Kit.....	74
Owner's Manual Storage.....	75
Side Cover Removal.....	76
Seat Removal.....	78
Shroud Removal	79

Service Procedures

Fluids & Filters

Fuel	80
Engine Oil & Filter.....	84
Air Cleaner	95

Engine

Clutch System.....	97
Engine Idle Speed.....	101
Spark Plug.....	103
Spark Arrester/Muffler	106

Chassis

Suspension	107
Brakes	114
Wheels	118
Tires	119
Side Stand	126
Drive Chain.....	127
Drive Chain Slider/Slipper/ Guide Slider	134

Electrical

Battery.....	135
--------------	-----

Appearance Care	140
-----------------------	-----

Service Your Honda

The following table summarizes the three types of inspections and servicing recommendations for your motorcycle. Both the pre-ride inspection and the scheduled maintenance at the recommended intervals are necessary to assure safe and dependable performance. The periodic checks provide additional confidence in your motorcycle's performance.

Type of Inspection/Service	Refer to page:	When Performed	Who Performs
Pre-ride Inspection	31	before every ride	you
Periodic Maintenance	62	monthly*	you
Maintenance Schedule	64	interval on schedule	your Honda dealer**

- * more often if you ride frequently or long distances; or anytime you clean your motorcycle
** unless you have the proper tools and service data and are mechanically qualified

The Importance of Maintenance

Keeping your motorcycle well-maintained is absolutely essential to your safety. It's also a good way to protect your investment, get maximum performance, avoid breakdowns, and have more fun. A properly maintained motorcycle will also help to reduce air pollution.

Since this motorcycle is capable of being ridden over rough off-road terrain as well as on pavement, careful pre-ride inspections and good maintenance are especially important.

Remember, proper maintenance is the owner's responsibility. Be sure to inspect your motorcycle before each ride, perform the periodic checks, and follow the Maintenance Schedule in this section.

⚠ WARNING

Improperly maintaining this motorcycle or failing to correct a problem before you ride can cause a crash in which you can be seriously hurt or killed.

Always follow the inspection and maintenance recommendations and schedules in this owner's manual.

If your motorcycle overturns or is involved in a crash, be sure your Honda dealer inspects all major parts, even if you are able to make some repairs.

Maintenance Safety

This section includes instructions on how to perform some important maintenance tasks. If you have basic mechanical skills, you can perform many of these tasks with the tools provided with your motorcycle.

Other tasks that are more difficult and require special tools are best performed by professionals. Wheel removal should normally be handled only by a Honda technician or other qualified mechanic. Instructions are included in this manual only to assist in emergency service.

Some of the most important safety precautions follow. However, we cannot warn you of every conceivable hazard that can arise in performing maintenance. Only you can decide whether or not you should perform a given task.

⚠ WARNING

Failure to properly follow maintenance instructions and precautions can cause you to be seriously hurt or killed.

Always follow the procedures and precautions in this owner's manual.

Maintenance Safety

Important Safety Precautions

- Make sure the engine is off before you begin any maintenance or repairs. This will help eliminate several potential hazards:

Carbon monoxide poisoning from engine exhaust. Be sure there is adequate ventilation whenever you operate the engine.

Burns from hot motorcycle parts. Let the engine and exhaust system cool before touching.

Injury from moving parts. Do not run the engine unless instructed to do so.

- Read the instructions before you begin, and make sure you have the tools and skills required.
- To help prevent the motorcycle from falling over, park it on a firm, level surface, using the side stand or a maintenance stand to provide support.
- To reduce the possibility of a fire or explosion, be careful when working around gasoline. Use only non-flammable solvent, not gasoline, to clean parts. Keep cigarettes, sparks, and flames away from all fuel-related parts.

Remember that your Honda dealer knows your motorcycle best and is fully equipped to maintain and repair it. To ensure the best quality and reliability, use only new genuine Honda parts or their equivalents for repair and replacement. If you have the tools and skills required for additional maintenance jobs, you can purchase an official Honda Service Manual (page 198).

Periodic Maintenance

In addition to the regularly scheduled maintenance (page 64) and daily pre-ride inspection (page 31), consider performing the periodic checks on the following page at least once a month, even if you haven't ridden your motorcycle, or as often as once a week if you ride frequently or for long distances. It's a good idea to perform this maintenance any time you clean your motorcycle.

Check the odometer reading and perform any scheduled maintenance checks that are needed (page 64). Remember, more frequent checks may be needed for riding in severe conditions.

Periodic Maintenance

Tires & Wheels	Check the air pressure with a gauge and add air if needed (page 119). Examine the tread for wear (page 121). Look closely for nails, embedded objects, cuts, and other types of damage (page 121). Roll your motorcycle so you can inspect the entire surface. Check the condition of the rims and spokes.
Fluids	Check the levels of the engine oil (page 88), and brake fluid (page 115). Add the correct fluid as necessary, and investigate the cause of any low fluid level.
Lights	Make sure the headlight, brake light, taillight, and turn signals are working properly.
Freeplay	Check the freeplay of the clutch lever (page 97) and throttle grip.
Drive Chain	Check condition, adjust slack, and lubricate as needed (page 128).
Fuses	Make sure you have a full supply of spare fuses.
Nuts & Bolts	Check the major fasteners and tighten as needed.

Maintenance Schedule

The required Maintenance Schedule that follows specifies how often you should have your motorcycle serviced, and what things need attention. It is essential to have your motorcycle serviced as scheduled to maintain safe, dependable performance and proper emission control.

The service intervals in this Maintenance Schedule are based on average riding conditions. Some items will need more frequent service if you ride in unusually wet or dusty areas or at full throttle. Consult your Honda dealer for recommendations applicable to your individual needs and use.

Some items in the Maintenance Schedule can be performed with basic mechanical skills and hand tools. Procedures for these items are provided in this manual. Other items involve more extensive procedures and may require special training, tools, and equipment. We recommend that you have your Honda dealer perform these tasks unless you have advanced mechanical skills and the required tools and equipment. Procedures for such items in this schedule are provided in an official Honda Service Manual available for purchase (page 198).

Maintenance Schedule

If you do not feel capable of performing a given task or need assistance, remember that your Honda dealer knows your motorcycle best and is fully equipped to maintain and repair it. If you decide to do your own maintenance, use only genuine Honda parts or their equivalents for repair or replacement to ensure the best quality and reliability.

Perform the pre-ride inspection (page 31) and owner maintenance (page 64) at each scheduled maintenance period.

Each item on the maintenance schedule requires some mechanical knowledge. Certain items (particularly those marked * and **) may require more technical information and tools. Consult your Honda dealer.

* Should be serviced by your Honda dealer, unless you have the proper tools and service data and are mechanically qualified. Refer to the official Honda Service Manual (page 198).

** In the interest of safety, we recommend these items be serviced only by your Honda dealer.

(cont'd)

Maintenance Schedule

Summary of Maintenance Schedule Notes & Procedures:

NOTES:

1. At higher odometer readings, repeat at the frequency interval established here.
2. Service more frequently if the motorcycle is ridden in unusually wet or dusty areas.
3. Service more frequently when riding OFF-ROAD.
4. Replace every 2 years, or at indicated odometer interval, whichever comes first. Replacement requires mechanical skill. Refer to the official Honda service manual.
5. California type only.

Maintenance Procedures:

I: inspect and clean, adjust, lubricate,
or replace, if necessary

C: clean

A: adjust

L: lubricate

R: replace

Maintenance Schedule

ITEM		FREQUENCY	NOTE	ODOMETER READING (Note 1)							Refer to page		
				× 1,000 mi	0.6	4	8	12	16	20		24	
				× 1,000 km	1.0	6.4	12.8	19.2	25.6	32.0	38.4		
EMISSION RELATED ITEMS	*	FUEL LINE										—	
	*	FUEL STRAINER SCREEN				C	C	C	C	C	C	—	
	*	THROTTLE OPERATION										—	
	*	CARBURETOR CHOKE										—	
		AIR CLEANER	2						R			R	95
		SPARK PLUG						R		R		R	103
	*	VALVE CLEARANCE											—
		ENGINE OIL				R	EVERY 2,000 mi (3,200 km)				R	84	
		ENGINE OIL FILTER				R		R		R		R	90
	*	ENGINE IDLE SPEED											101
	*	SECONDARY AIR SUPPLY SYSTEM											—
	*	EVAPORATIVE EMISSION CONTROL SYSTEM	5										—

- * Should be serviced by your Honda dealer, unless you have the proper tools and service data and are mechanically qualified. Refer to the official Honda Service Manual (page 198).

(cont'd)

Maintenance Schedule

			FREQUENCY		ODOMETER READING (Note 1)							Refer to
					× 1,000 mi	0.6	4	8	12	16	20	
ITEM		NOTE	× 1,000 km	1.0	6.4	12.8	19.2	25.6	32.0	38.4		
NON-EMISSION RELATED ITEMS	DRIVE CHAIN	3		I, L EVERY 500 mi (800 km)							127	
	DRIVE CHAIN SLIDER				I	I	I	I	I	I	134	
	BRAKE FLUID	4			I	I	R	I	I	R	115	
	BRAKE PAD WEAR				I	I	I	I	I	I	117	
	BRAKE SYSTEM			I		I		I		I	114	
	* BRAKE LIGHT SWITCH					I		I		I	—	
	* HEADLIGHT AIM					I		I		I	—	
	CLUTCH SYSTEM			I	I	I	I	I	I	I	97	
	SIDE STAND					I		I		I	126	
	* SUSPENSION					I		I		I	—	
	* SPARK ARRESTER/MUFFLER					C	C	C	C	C	C	106
	* NUTS, BOLTS, FASTENERS	3		I		I		I		I	—	
	** WHEELS/TIRES	3		I	I	I	I	I	I	I	118	
** STEERING HEAD BEARINGS			I		I		I		I	—		

* Should be serviced by your Honda dealer, unless you have the proper tools and service data and are mechanically qualified. Refer to the official Honda Service Manual (page 198).

**In the interest of safety, we recommend these items be serviced only by your Honda dealer.

Maintenance Record

Keeping an accurate maintenance record will help ensure that your motorcycle is properly maintained. Retain detailed receipts to verify the maintenance was performed. If the motorcycle is sold, these receipts should be transferred with the motorcycle to the new owner. Make sure whoever performs the maintenance completes this record. All scheduled maintenance, including the 600 mile (1,000 km) initial maintenance, is considered a normal owner operating cost and will be charged for by your dealer. Use the space under Notes to record anything you want to remind yourself about or mention to your dealer.

Miles (km)	Odometer	Date	Performed By:	Notes
600 (1,000)				
4,000 (6,400)				
8,000 (12,800)				
12,000 (19,200)				
16,000 (25,600)				
20,000 (32,000)				

(cont'd)

Maintenance Record

Miles (km)	Odometer	Date	Performed By:	Notes
24,000 (38,400)				
28,000 (44,800)				
32,000 (51,200)				
36,000 (57,600)				
40,000 (64,000)				
44,000 (70,400)				
48,000 (76,800)				
52,000 (83,200)				
56,000 (89,600)				
60,000 (96,000)				
64,000 (102,400)				
68,000 (108,800)				

Component Locations

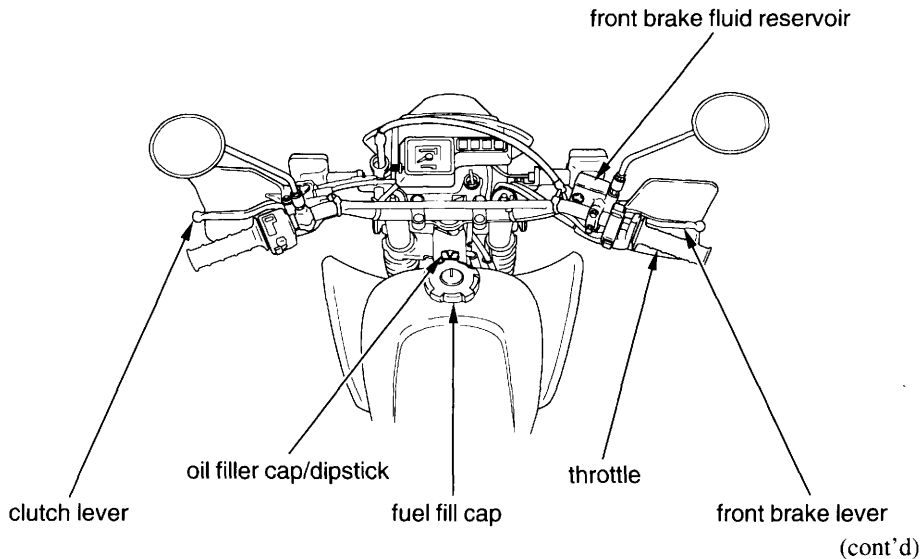

Component Locations

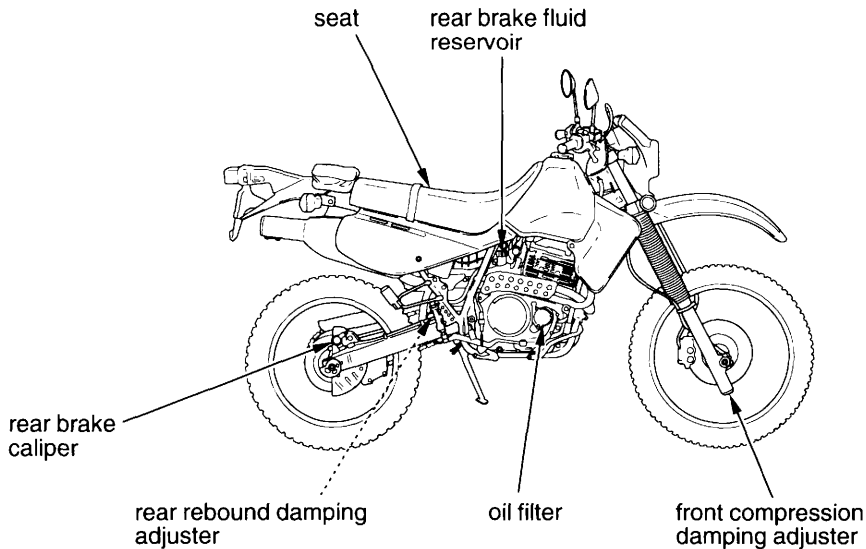

Component Locations

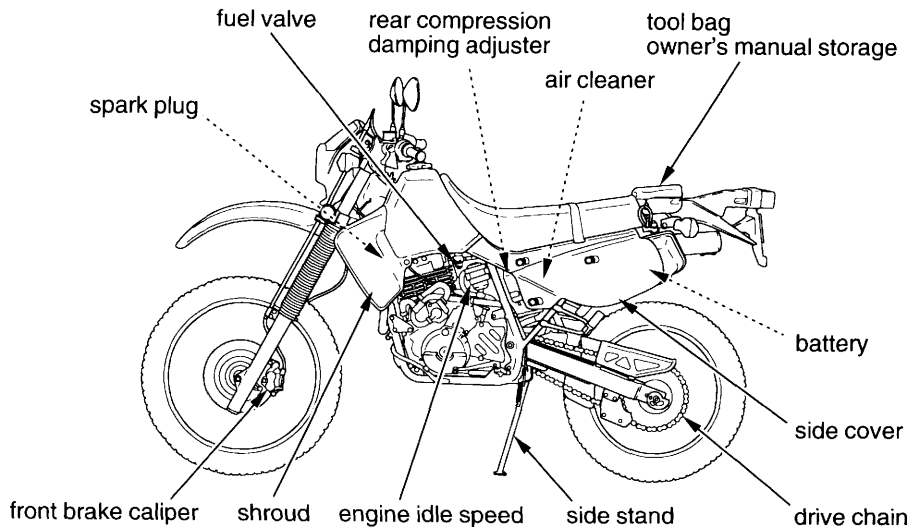

Tool Kit

The tool kit is stored in the tool bag behind the seat. Some roadside repairs, minor adjustments, and parts replacement can be performed with the tools contained in the kit.

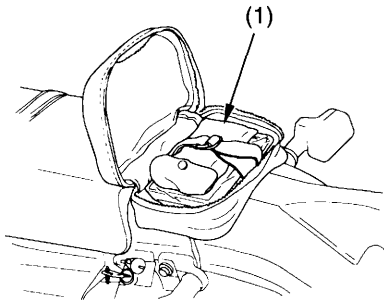

(1) tool kit

- 8 × 12 mm open end wrench
- 10 × 14 mm open end wrench
- pliers
- no. 2 screwdriver
- no. 2 Phillips screwdriver
- no. 3 Phillips screwdriver
- 10 × 12 mm box end wrench
- 5 mm hex wrench
- screwdriver handle
- 24 mm box end wrench
- 17 mm box end wrench
- extension bar
- spark plug wrench
- tool bag

Owner's Manual Storage

Your motorcycle provides storage for the owner's manual so you'll have it with you for easy reference. Store your owner's manual (and other documents) in the plastic storage bag (1) in the tool bag behind the seat.

Be careful not to flood this area when washing your motorcycle.

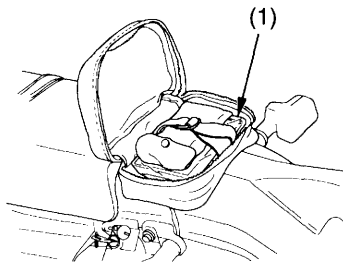

(1) owner's manual storage bag

Side Cover Removal

Refer to *Safety Precautions* on page 60 .

The left side cover (1) must be removed for seat removal, or to service the air cleaner, fuse or battery maintenance.

LEFT SIDE

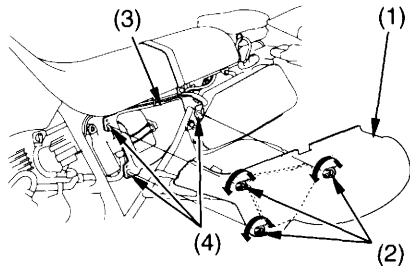

- (1) left side cover
- (2) quick-release fasteners
- (3) air cleaner housing
- (4) slots

Left Side Cover Removal

1. Lift the D-ring on each quick-release fastener (2) and turn it counterclockwise until it releases.
2. Remove the left side cover.

Left Side Cover Installation

1. Align the left side cover with the air cleaner housing (3).
2. Push each quick-release fastener into its slot (4), lift its D-ring, and turn it clockwise until it is secure.

Side Cover Removal

Refer to *Safety Precautions* on page 60 .

The right side cover (5) must be removed for seat removal.

RIGHT SIDE

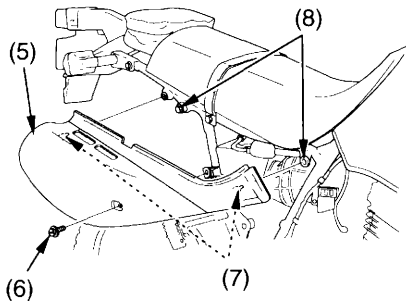

(5) right side cover
(6) bolt

(7) prongs
(8) grommets

Right Side Cover Removal

1. Remove the attaching bolt (6).
2. Pull the right side cover out.

Right Side Cover Installation

1. Position the right side cover, so the prongs (7) are aligned with the frame grommets (8).
2. Push both prongs in.
3. Install the attaching bolt and tighten it.

Seat Removal

Refer to *Safety Precautions* on page 60.

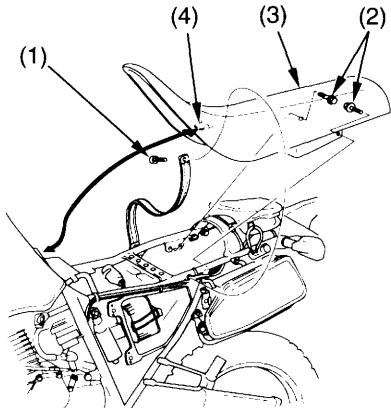

- | | |
|-------------------------|----------|
| (1) belt attaching bolt | (3) seat |
| (2) seat mount bolts | (4) tab |

Removal

1. Remove both side covers (page 76).
2. Remove the belt attaching bolt (1).
3. Remove the seat mounting bolts (2).
4. Pull the seat (3) backward.

Installation

1. Insert the tab (4) into the recess under the frame.
2. Tighten the seat mounting bolts securely.
3. Fasten the belt over the seat and tighten the bolt securely.
4. Install both side covers.

Shroud Removal

Refer to *Safety Precautions* on page 60 .

The shroud must be removed for access to the spark plug.

LEFT SIDE

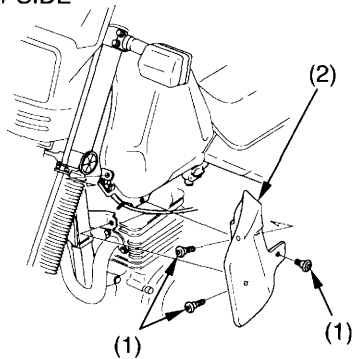

- (1) socket bolts
- (2) shroud

Removal

1. Remove the three socket bolts (1).
2. Remove the shroud (2).

Installation

- Installation can be done in the reverse order of removal.

Fuel

Refer to *Safety Precautions* on page 60.

Fuel Recommendation

type	unleaded
pump octane number	86 (or higher)

We recommend that you use unleaded fuel because it produces fewer engine deposits and extends the life of exhaust system components.

Your engine is designed to use any gasoline that has a pump octane number of 86 or higher. Gasoline pumps at service stations normally display the pump octane number. For information on the use of oxygenated fuels, see page 195.

Use of lower octane gasoline can cause persistent “pinging” or “spark knock” (a loud rapping noise) which, if severe, can lead to engine damage. Light pinging experienced while operating under a heavy load, such as climbing a hill, is no cause for concern.

If pinging or spark knock occurs at a steady engine speed under normal load, change brands of gasoline. If pinging or spark knock persists, consult your Honda dealer.

Never use stale or contaminated gasoline or an oil/gasoline mixture. Avoid getting dirt, dust, or water in the fuel tank.

Fuel Capacity

Fuel tank capacity, including reserve:
2.77 US gal (10.5 ℓ)
Reserve capacity:
0.61 US gal (2.3 ℓ)

The tank should be refilled as soon as possible after switching to reserve, and the fuel valve should be returned to the ON position after refueling to avoid running out of fuel with no reserve.

Refueling Procedure

Refer to *Safety Precautions* on page 60.

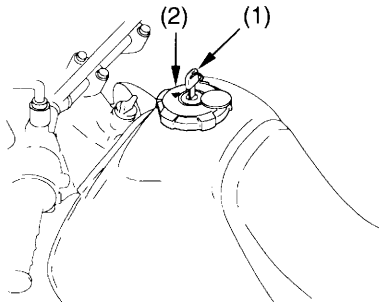

(1) ignition key (2) fuel fill cap

1. Insert the ignition key (1) in the fuel fill cap (2) and turn it clockwise.

(cont'd)

Fuel

2. Turn the fuel fill cap counterclockwise and remove it.
(For California model, see next page)
3. Add fuel until the level reaches the bottom of the filler neck (3). Avoid overfilling the tank. There should be no fuel in the filler neck.

⚠ WARNING

Gasoline is highly flammable and explosive. You can be burned or seriously injured when handling fuel.

- Stop the engine and keep heat, sparks and flame away.
- Handle fuel only outdoors.
- Wipe up spills immediately.

4. After refueling, be sure to tighten the fuel fill cap firmly by turning it clockwise until the arrow mark (4) on the cap faces forward.
5. Turn the ignition key counterclockwise.
6. Remove the ignition key from the cap.
7. Turn the fuel valve ON (if it was set on RES).

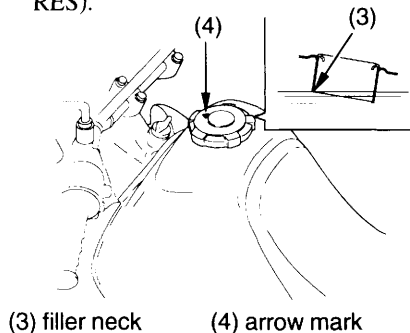

Fuel fill cap removal and installation for California version (USA only):

As sold in California, this motorcycle is equipped with an evaporative emission control system (page 190). For the system to function properly, observe the following when removing and installing the fuel fill cap.

1. To open the fuel fill cap (1), turn the cap counterclockwise.

Do not disconnect the breather tube (2).

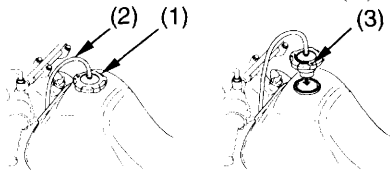

(1) fuel fill cap
(2) breather tube

(3) arrow mark

2. To close the cap, align the tabs of the fuel fill cap to the slots of the filler neck with the arrow mark (3) on the cap towards the rear of the motorcycle.
3. Turn the cap clockwise until the arrow mark points towards the front.

Make sure that the breather tube is not twisted or blocked when the cap is secure in place.

NOTICE

If you replace the fuel fill cap, use only a genuine Honda replacement part or its equivalent. Failure to use the proper part could cause serious fuel system problem.

Engine Oil & Filter

Engine oil quality is a major factor that affects both the performance and the service life of the engine.

Using the proper oil (page 85) and filter, and regularly checking, adding, and changing oil will help extend your engine's life. Even the best oil wears out. Changing oil helps get rid of dirt and deposits in the engine. Operating the engine with old or dirty oil can damage your engine. Running the engine with insufficient oil can cause serious damage to the engine and transmission.

Change the engine oil as specified in the maintenance schedule on page 67 .

When running in very dusty conditions, oil changes should be performed more frequently than specified in the maintenance schedule.

When riding at high or continuous speed on the highway, check the oil level frequently.