

HONDA

GC135 • GC160

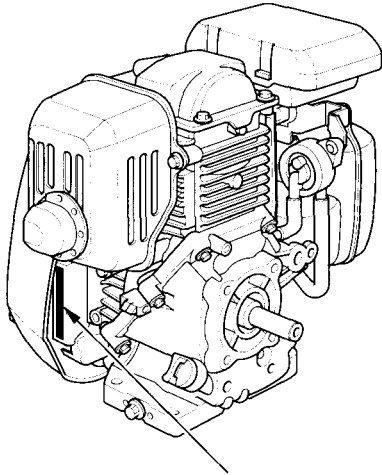

SERIAL NUMBER AND ENGINE TYPE

OWNER'S MANUAL



32ZL8601
00X32-ZL8-6010

© HONDA MOTOR CO., LTD. 1997

1

英 O HC 100009709

Thank you for purchasing a Honda engine.

This manual covers the operation and maintenance of your engine:
GC135•GC160

All information in this publication is based on the latest product information available at the time of printing.

Honda Motor Co., Ltd. reserves the right to make changes at any time without notice and without incurring any obligation.

No part of this publication may be reproduced without written permission.

This manual should be considered a permanent part of the engine and should remain with it if it is resold.

Pay special attention to statements preceded by the following words:

▲WARNING Indicates a strong possibility of severe personal injury or death if instructions are not followed.

CAUTION: Indicates a possibility of personal injury or equipment damage if instructions are not followed.

NOTICE Indicates that equipment or property damage can result if instructions are not followed.

NOTE: Gives helpful information.

If a problem should arise, or if you have any questions about your engine, consult an authorized Honda dealer.

▲WARNING
The Honda engine is designed to give safe and dependable service if operated according to instructions. Read and understand the Owner's Manual before operating the engine. Failure to do so could result in personal injury or equipment damage.

1 SAFETY INSTRUCTIONS

▲WARNING

To ensure safe operation—



• Honda engine is designed to give safe and dependable service if operated according to instructions. Read and understand the Owner's Manual before operating the engine. Failure to do so could result in personal injury or equipment damage.

- Always make a pre-operation inspection (page 6) before you start the engine. You may prevent an accident or equipment damage.
- To prevent fire hazards and to provide adequate ventilation, keep the engine at least 1 meter (3 feet) away from buildings and other equipment during operation. Do not place flammable objects close to the engine.
- Children and pets must be kept away from the area of operation due to a possibility of burns from hot engine components or injury from any equipment the engine may be used to operate.
- Know how to stop the engine quickly, and understand the operation of all controls. Never permit anyone to operate the engine without proper instructions.
- Do not place flammable objects such as gasoline, matches, etc., close to the engine while it is running.
- Refuel in a well-ventilated area with the engine stopped. Gasoline is highly flammable and explosive under certain conditions.
- Do not overfill the fuel tank. There should be no fuel in the filler neck.
Make sure that the filler cap is closed securely.

Safety Instruction

▲WARNING

To ensure safe operation—

- If any fuel is spilled, clean it up completely and allow petroleum vapours to dissipate before starting the engine.
- Do not smoke or allow flames or sparks where the engine is refueled or where gasoline is stored.
- Exhaust gas contains poisonous carbon monoxide. Avoid inhalation of exhaust gases. Never run the engine in a closed garage or confined area.
- Place the engine on a stable surface. Do not tilt the engine more than 20° from horizontal. Operating at excessive angles may result in fuel spillage.
- Do not place anything on the engine, as it may create a fire hazard.
- A spark arrester is available as an optional part for this engine. It is illegal in some areas to operate an engine without a spark arrester. Check local laws and regulations before operating.
- The muffler becomes very hot during operation and remains hot for a while after stopping the engine. Be careful not to touch the muffler while it is hot. To avoid severe burns or fire hazards, let the engine cool before transporting it or storing it indoors.

SAFETY INSTRUCTION LOCATION

This instruction warns you of potential hazards that can cause serious injury. Read it carefully.

READ OWNER'S MANUAL BEFORE OPERATION.

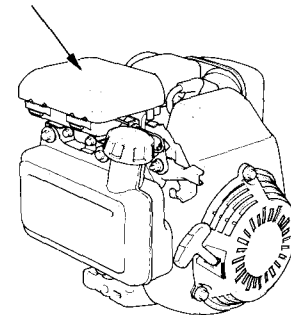

2 COMPONENT IDENTIFICATION

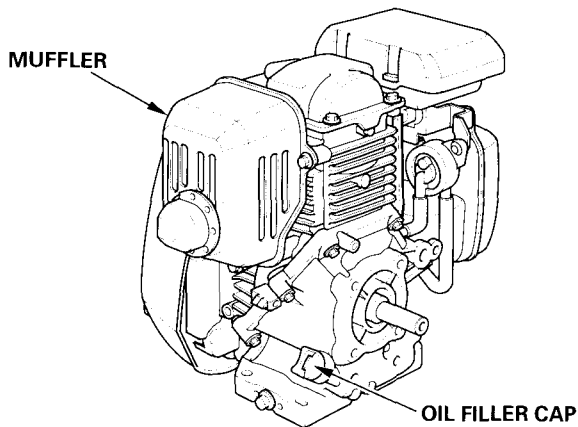
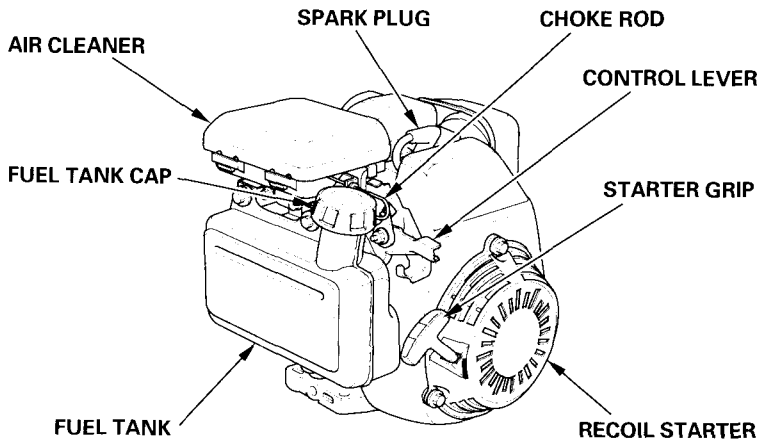

5

3 PRE-OPERATION CHECK

1. Engine oil level

CAUTION:

- Running the engine with insufficient oil can cause serious engine damage.
- Be sure to check the engine on a level surface with the engine stopped.

1. Remove the oil filler cap and check the oil level.
2. If the level is low, add the recommended oil to the edge of the oil filler hole.

Use Honda 4-stroke, or an equivalent high detergent, premium quality motor oil certified to meet or exceed U.S. automobile manufacturer's requirements for service classification SG, SF. Motor oils classified SG, SF will show this designation on the container.

SAE 10W-30 is recommended for general, all temperature use. If single viscosity oil is used, select the appropriate viscosity for the average temperature in your area.

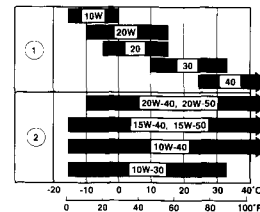

Ambient temperature
 ① SINGLE VISCOSITY
 ② MULTI VISCOSITY

CAUTION:

Using nondetergent oil or 2-stroke engine oil could shorten the engine's service life.

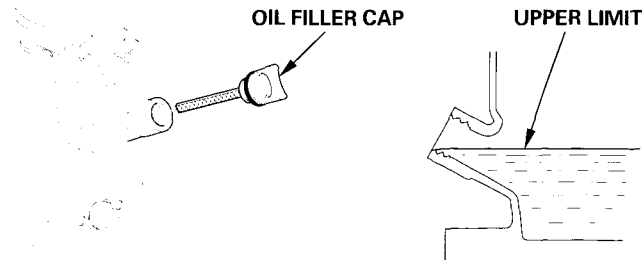

6

2. Air cleaner

CAUTION:

Never run the engine without the air cleaner. Rapid engine wear will result.

Remove the air cleaner cover and check the cleaner for dirt or obstruction of the element (page 19).

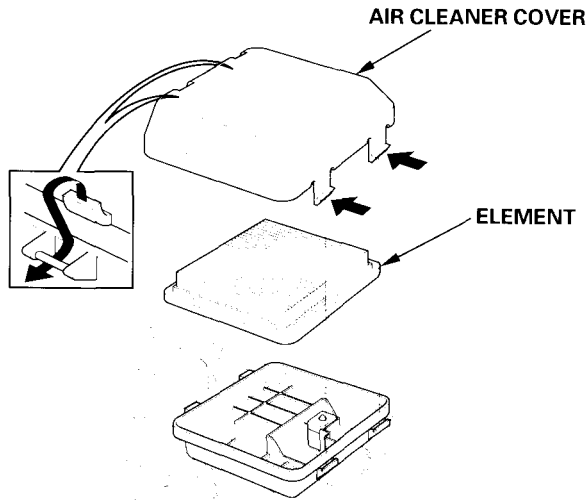

3. Fuel

Use automotive gasoline (Unleaded or lowleaded is preferred to minimize combustion chamber deposits).

FOR NEW SOUTH WALES ONLY:

Use unleaded fuel only.

Never use an oil/gasoline mixture or dirty gasoline. Avoid getting dirt, dust or water in the fuel tank.

▲WARNING

- Gasoline is extremely flammable and is explosive under certain conditions.
- Refuel in a well-ventilated area with the engine stopped. Do not smoke or allow flames or sparks in the area where the engine is refueled or where gasoline is stored.
- Do not overfill the fuel tank (there should be no fuel above the upper limit mark). After refueling, make sure the tank cap is closed properly and securely.
- Be careful not to spill fuel when refueling. Spilled fuel or fuel vapor may ignite. If any fuel is spilled, make sure the area is dry before starting the engine.
- Avoid repeated or prolonged contact with skin or breathing of vapor.

KEEP OUT OF REACH OF CHILDREN.

Fuel tank capacity

GC135: 1.7 l (0.45 US gal , 0.37 Imp gal)

GC160: 2.0 l (0.53 US gal , 0.44 Imp gal)

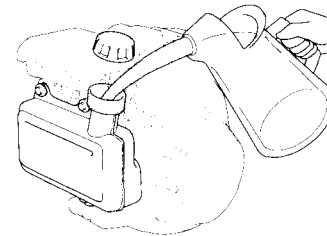

UPPER LIMIT MARK

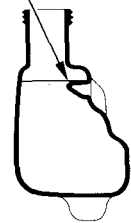

GASOLINES CONTAINING ALCOHOL

If you decide to use a gasoline containing alcohol (gasohol), be sure it's octane rating is at least as high as that recommended by Honda. There are two types of "gasohol": one containing ethanol, and the other containing methanol. Do not use gasohol that contains more than 10% ethanol. Do not use gasoline containing methanol (methyl or wood alcohol) that does not also contain cosolvents and corrosion inhibitors for methanol. Never use gasoline containing more than 5% methanol, even if it has cosolvents and corrosion inhibitors.

NOTE:

- Fuel system damage or engine performance problems resulting from the use of fuels that contain alcohol is not covered under the warranty. Honda cannot endorse the use of fuels containing methanol since evidence of their suitability is as yet incomplete.
- Before buying fuel from an unfamiliar station, try to find out if the fuel contains alcohol, if it does, confirm the type and percentage of alcohol used. If you notice any undesirable operating symptoms while using a gasoline that contains alcohol, or one that you think contains alcohol, switch to a gasoline that you know does not contain alcohol.

4 STARTING THE ENGINE

1. Pull the choke rod to the CLOSED position.

NOTE:

Do not use the choke if the engine is warm or the air temperature is high.

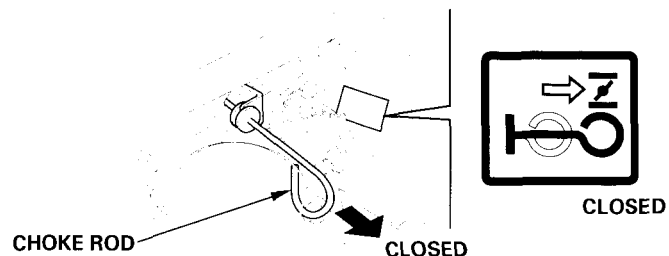

2. Control lever with engine stop function:

Move the control lever away from the SLOW position, about 1/3 of the way toward the FAST position.

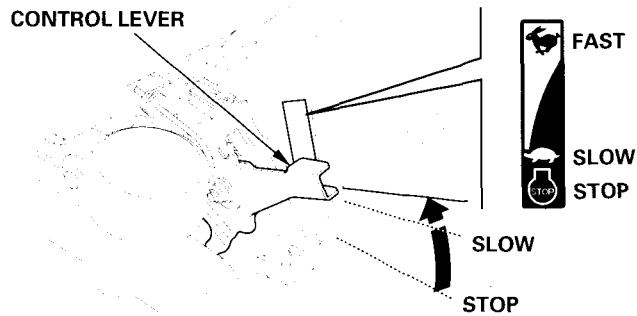

- Control lever with only engine stop function:
Move the control lever to the ON position.

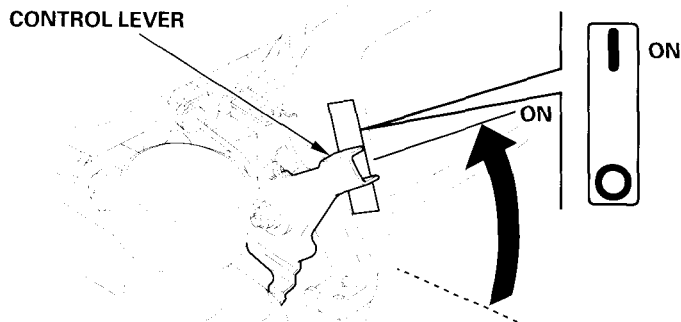

3. Pull the starter grip lightly until resistance is felt, then pull briskly.

CAUTION:

Do not allow the starter grip to snap back against the engine. Return it gently to prevent damage to the starter.

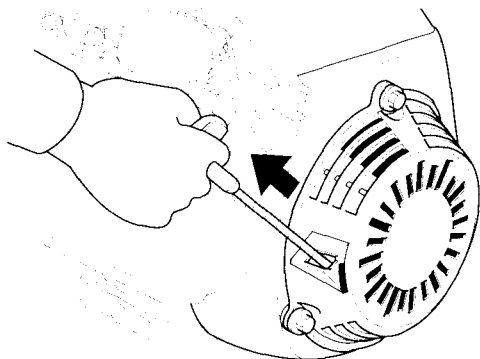

● **High altitude operation**

At high altitude, the standard carburetor air-fuel mixture will be excessively rich. Performance will decrease, and fuel consumption will increase.

High altitude performance can be improved by installing a smaller diameter main fuel jet in the carburetor and readjusting the pilot screw. If you always operate the engine at altitudes higher than 1,830 m (6,000 feet) above sea level, have your authorized Honda dealer perform these carburetor modifications.

Even with suitable carburetor jetting, engine horsepower will decrease approximately 3.5% for each 305 m (1,000 feet) increase in altitude. The affect of altitude on horsepower will be greater than this if no carburetor modification is made.

CAUTION:

Operation of the engine at an altitude lower than the carburetor is jetted for may result in reduced performance, overheating, and serious engine damage caused by an excessively lean air/fuel mixture.

Oil alert system (where equipped)

The Oil Alert System is designed to prevent engine damage caused by an insufficient amount of oil in the crankcase. Before the oil level in the crankcase can fall below a safe limit, the Oil Alert System will automatically stop the engine (the engine switch will remain in the ON position).

NOTICE

If the engine stops and will not restart, check the engine oil level (page 6) before troubleshooting in other areas.

5 OPERATION

1. If the choke rod has been pulled to the CLOSED position to start the engine, push it to the OPEN position as soon as the engine warms up enough to run smoothly.

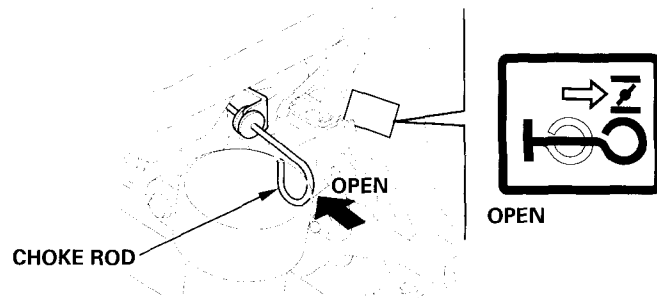

2. Control lever with engine stop function:
Position the control lever for the desired engine speed.

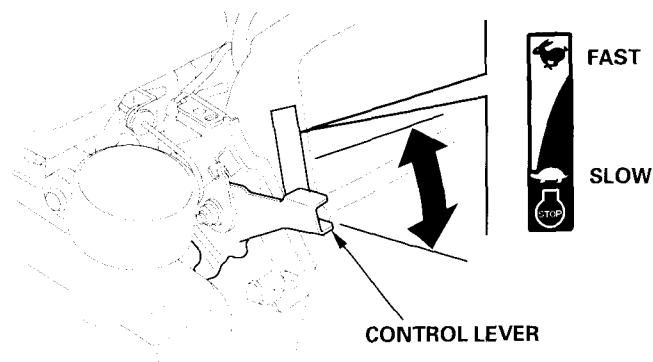

6 STOPPING THE ENGINE

- Control lever with engine stop function:
Move the control lever to the STOP position.

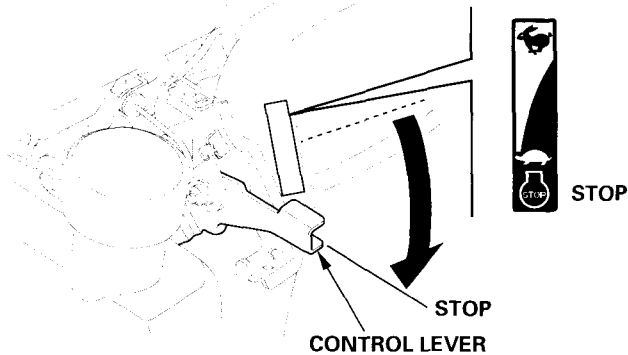

- Control lever with only engine stop function:
Move the control lever to the OFF position.

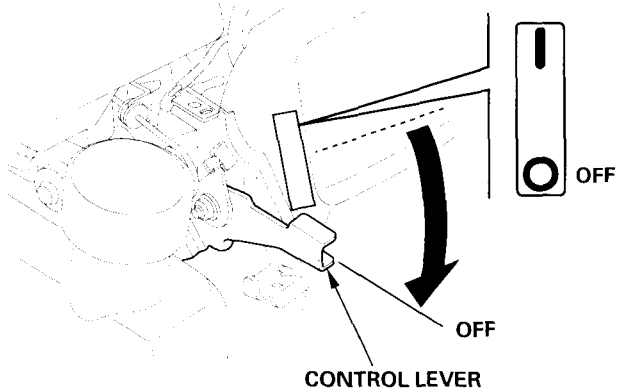

7 MAINTENANCE

▲WARNING

- Shut off the engine before performing any maintenance.
- To prevent accidental start-up, disconnect the spark plug cap.
- The engine should be serviced by an authorized Honda dealer unless the owner has proper tools and service data and feels he is mechanically qualified.

CAUTION:

Use only genuine HONDA parts or their equivalent. The use of replacement parts which are not of equivalent quality may damage the engine.

Periodic inspection and adjustment of the Honda engine is essential if high level performance is to be maintained. Regular maintenance will also ensure a long service life. The required service intervals and the kind of maintenance to be performed are described on the following table.

Maintenance Schedule

REGULAR SERVICE PERIOD Perform at every indicated month or operating hours interval, whichever comes first.		Before use	First month or 5 hrs.	Every season or 25 hrs.	Every season or 50 hrs.	Every 100 hrs.	Every 150 hrs.	
ITEM								
Engine oil	Check	○						
	Change		○		○ (2)			
Air cleaner	Check	○						
	Clean			○ (1)				
Spark plug	Check Clean					○		
Spark arrester (optional part)	Clean					○		
Fuel tank and strainer	Clean					○ (3)		
Valve clearance	Check - Adjust						○ (3)	
Fuel line	Check	Every 2 years (Replace if necessary) (3)						

NOTE:

(1): Service more frequently when used in dusty areas.

(2): Change engine oil every 25 hours when used under heavy load or in high ambient temperature.

(3): These items should be serviced by an authorized Honda dealer, unless the owner has the proper tools and is mechanically proficient. See the Honda Shop Manual.

1. Oil change

Drain the oil while the engine is still warm to assure rapid and complete draining.

1. Remove the oil filler cap and drain plug to drain the oil.
2. Install the drain plug, and tighten it securely.
3. Refill with the recommended oil (see page 6) and check the oil level.
4. Install the oil filler cap.

ENGINE OIL CAPACITY: 0.58 l (0.61 US qt , 0.51 Imp qt)

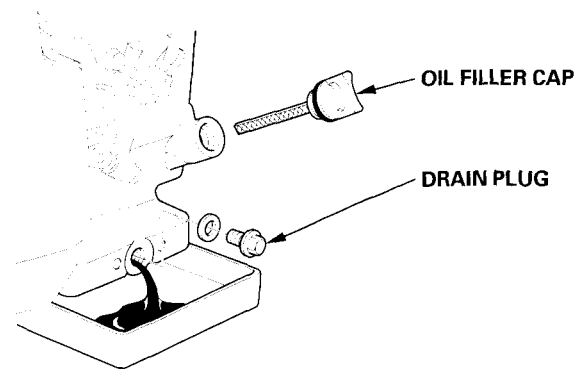

Wash your hands with soap and water after handling used oil.

NOTE:

Please dispose of used motor oil in a manner that is compatible with the environment. We suggest you take it in a sealed container to your local service station for reclamation. Do not throw it in the trash or pour it on the ground.

2. Air cleaner service

A dirty air cleaner will restrict air flow to the carburetor. To prevent carburetor malfunction, service the air cleaner regularly. Service more frequently when operating the engine in extremely dusty areas.

CAUTION:

Never run the engine without the air cleaner. Rapid engine wear will result.

1. Press the latch tabs on the fuel tank side of the air cleaner cover, and remove the air cleaner cover.

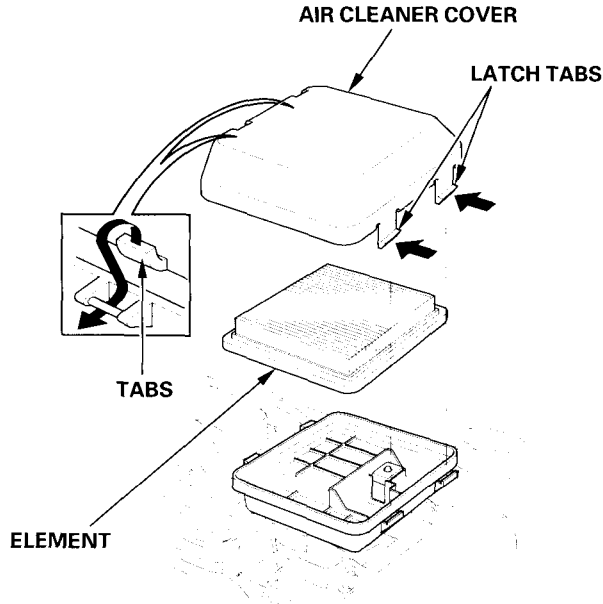

2. Remove the element. Carefully check the element for holes or tears and replace if damaged.
3. Tap the element lightly several times on a hard surface to remove excess dirt, or blow compressed air through the filter from the inside out. Never try to brush the dirt off; brushing will force dirt into the fibers. Replace the element if it is excessively dirty.
4. Install the element and air cleaner cover.

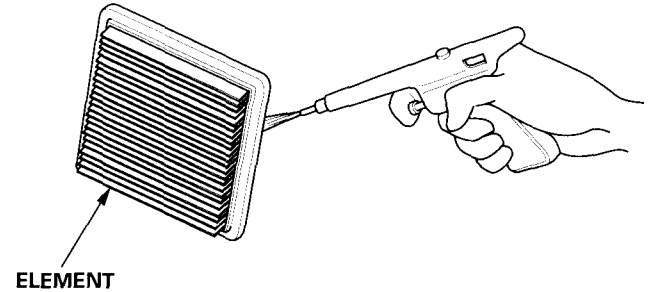

3. Spark plug service

Recommended spark plug:

BPR6ES (NGK)

CAUTION:

Never use a spark plug of incorrect heat range.

To ensure proper engine operation, the spark plug must be properly gapped and free of deposits.

1. Remove the spark plug cap and use a spark plug wrench to remove the plug.

⚠ WARNING

If the engine has been running, the muffler will be very hot. Be careful not to touch the muffler.

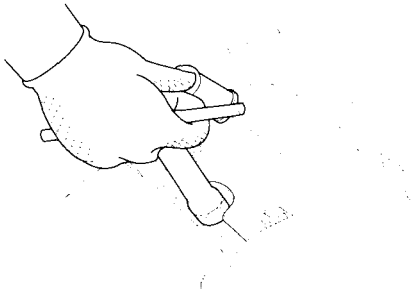

2. Visually inspect the spark plug. Discard the spark plug if there is apparent wear, or if the insulator is cracked or chipped. Clean the spark plug with a wire brush if it is to be reused.

3. Measure the plug gap with a feeler gauge. Correct as necessary by bending the side electrode.

The gap should be:

0.70 – 0.80 mm (0.028 – 0.031 in)

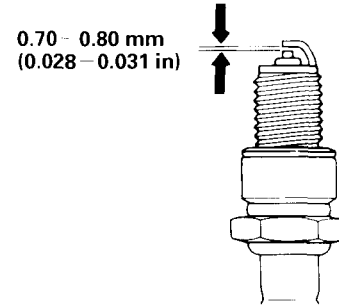

4. Check that the spark plug washer is in good condition and thread the spark plug in by hand to prevent cross-threading.

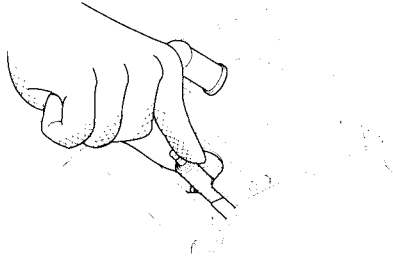

5. After the spark plug is seated, tighten with a spark plug wrench to compress the washer.

NOTE:

When installing a new spark plug, tighten 1/2 turn after the spark plug seats to compress the washer. When reinstalling a used spark plug, tighten 1/8 – 1/4 turn after the spark plug seats to compress the washer.

CAUTION:

The spark plug must be securely tightened. An improperly tightened spark plug can become very hot and may damage the engine.

4. Spark arrester maintenance (optional part)

▲WARNING

If the engine has been running, the muffler will be very hot. Allow it to cool before proceeding.

CAUTION:

The spark arrester must be serviced every 100 hours to maintain its efficiency.

1. Remove the muffler protector by removing the three 6 mm bolts.
2. Remove the spark arrester from the muffler by removing the two screws. (Taking care not to damage the wire mesh.)

NOTE:

Check for carbon deposits around the exhaust port and the spark arrester, and clean if necessary.

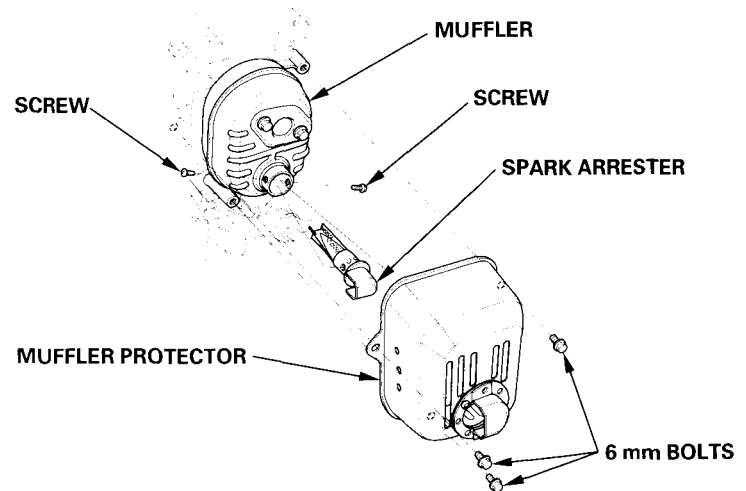

3. Use a brush to remove carbon deposits from the spark arrester screen.

CAUTION:

Be careful not to damage the spark arrester screen.

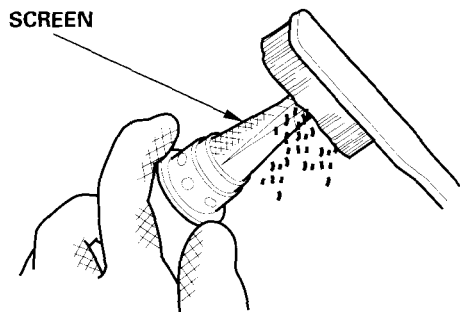

NOTE:

The spark arrester must be free of breaks and holes. Replace, if necessary.

4. Install the spark arrester and the muffler in the reverse order of disassembly.

8 TRANSPORTING/STORAGE

▲WARNING

When transporting the engine, keep the engine level to prevent fuel spillage. Fuel vapor or spilled fuel may ignite.

Before storing the unit for an extended period;

1. Be sure the storage area is free of excessive humidity and dust.
2. Drain the fuel tank and carburetor into a suitable gasoline container:
 - A. Empty the fuel tank into an approved gasoline container using a commercially available hand siphon.
 - B. Loosen the carburetor drain screw to drain the carburetor.
 - C. Retighten the drain screw.

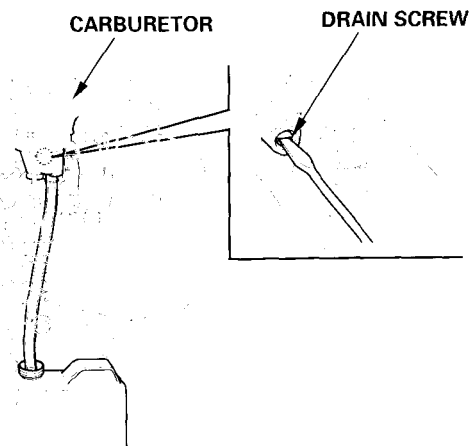

▲WARNING

Gasoline is extremely flammable and is explosive under certain conditions. Do not smoke or allow flames or sparks in the area.

3. Change the engine oil (page 18).

4. Pull the starter rope slowly until resistance is felt. This closes the valves, and protects them from dust and corrosion.

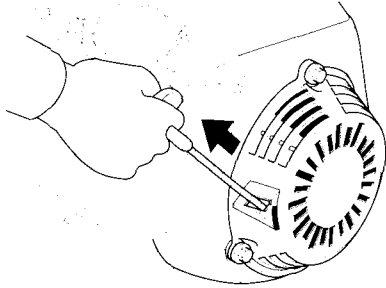

5. Coat areas that may rust with a light film of oil. Cover the engine and store it on a level surface in a dry, dust free area.

9 TROUBLESHOOTING

When the engine will not start:

1. Is there fuel in the fuel tank?
2. Is gasoline reaching the carburetor?
To check, loosen the drain screw.

▲WARNING

If any fuel is spilled, make sure the area is dry before testing the spark plug or starting the engine. Spilled fuel or fuel vapor may ignite.

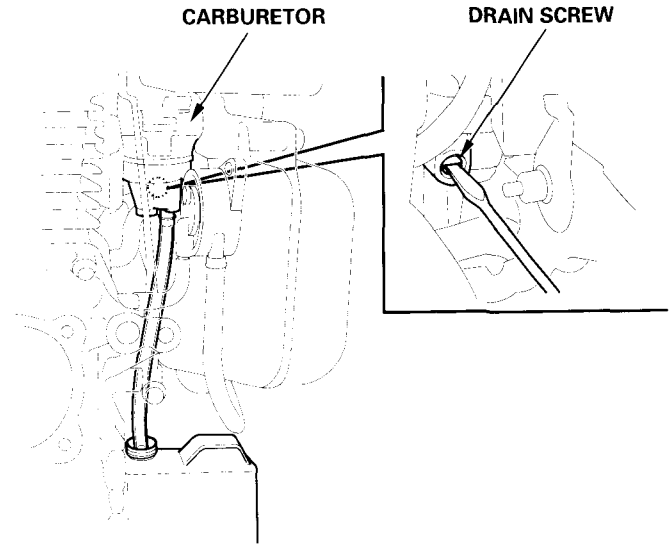

3. Is the control lever positioned properly (page 10, 11)?
4. Is there a spark at the spark plug?
 - a. Remove the spark plug cap. Clean any dirt from around the spark plug base, then remove the spark plug.
 - b. Install the spark plug in the plug cap.
 - c. Grounding the side electrode to any engine ground, pull the recoil starter to see if sparks jump across the gap.

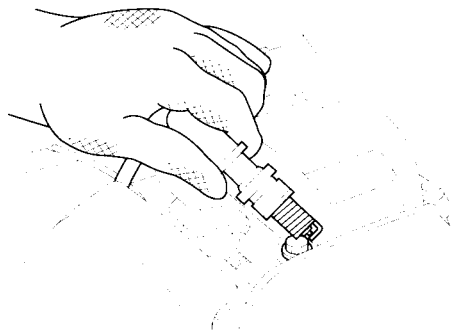

- d. If there is no spark, replace the plug.
If OK, reinstall the spark plug and try to start the engine again according to the instructions.
5. If the engine still does not start, take the engine to an authorized Honda dealer.

10 SPECIFICATIONS

GC135

Dimensions	GC135	
Power equipment description code	GCAJ	
	Length	330 mm (13.0 in)
	Width	369 mm (14.5 in)
	Height	315 mm (12.4 in)
Dry weight	11.2 kg (24.7 lbs)	

Engine

Engine type	4-stroke, overhead cam, 1 cylinder
Displacement	135 cm ³ (8.2 cu-in)
Bore x Stroke	64 × 42 mm (2.5 × 1.7 in)
Max. output	2.9 kW (4.0 PS)/3,600 rpm
Max. torque	8.6 N·m (0.88 kgf-m)/2,500 rpm
Fuel consumption	313 g/kWh (230 g/PSH)
Cooling system	Forced air
Ignition system	Transistor magneto
PTO shaft rotation	Counterclockwise
Fuel tank capacity	1.7 ℓ (0.45 US gal, 0.37 Imp gal)
Engine oil capacity	0.58 ℓ (0.61 US qt, 0.51 Imp qt)
Engine oil	Service classification SF or SG; SAE 10W-30
Spark plug	BPR6ES (NGK)

NOTE:

Specifications may vary according to the types, and are subject to change without notice.

GC160

Dimensions	GC160	
Power equipment description code	GCAH	
Length	337 mm (13.3 in)	
Width	369 mm (14.5 in)	
Height	331 mm (13.0 in)	
Dry weight	11.5 kg (25.4 lbs)	

Engine

Engine type	4-stroke, overhead cam, 1 cylinder	
Displacement	160 cm ³ (9.8 cu-in)	
Bore x Stroke	64 × 50 mm (2.5 × 2.0 in)	
Max. output	3.7 kW (5.0 PS)/3,600 rpm	
Max. torque	10.3 N·m (1.05 kgf·m)/2,500 rpm	
Fuel consumption	313 g/kWh (230 g/PSh)	
Cooling system	Forced air	
Ignition system	Transistor magneto	
PTO shaft rotation	Counterclockwise	
Fuel tank capacity	2.0 ℓ (0.53 US gal , 0.44 Imp gal)	
Engine oil capacity	0.58 ℓ (0.61 US qt , 0.51 Imp qt)	
Engine oil	Service classification SF or SG; SAE 10W-30	
Spark plug	BPR6ES (NGK)	

NOTE:

Specifications may vary according to the types, and are subject to change without notice.